



**SmartGen**  
ideas for power

# HLS300A

## POWER SHARE MODULE

## USER MANUAL

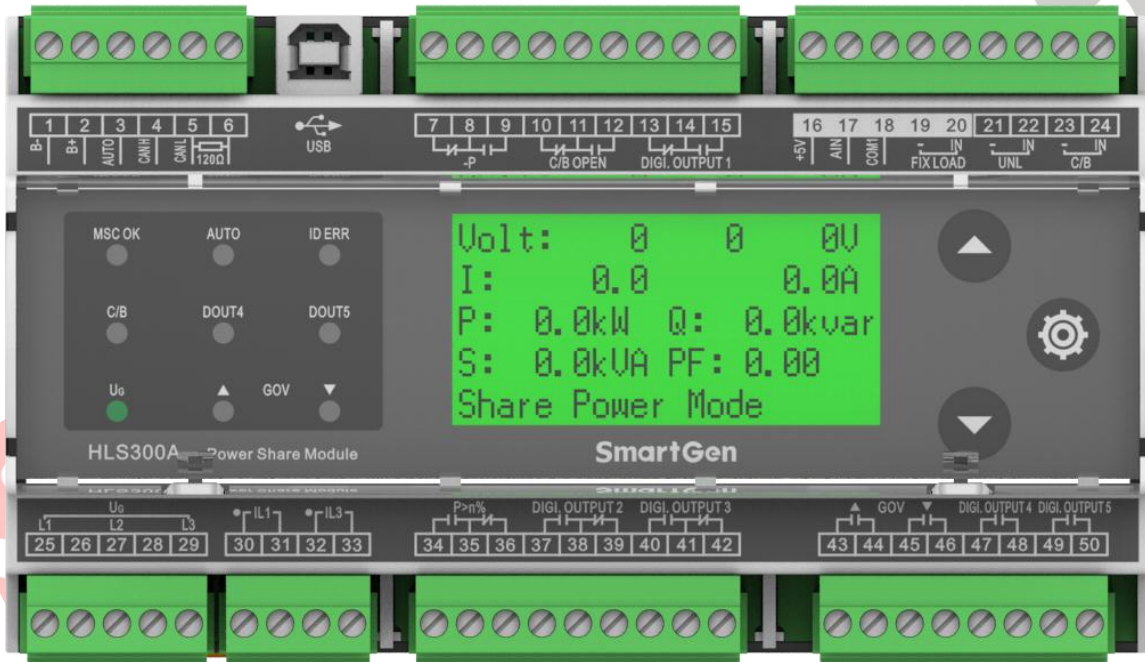

**SMARTGEN (ZHENGZHOU) TECHNOLOGY CO.,LTD.**



Chinese trademark

**SmartGen** English trademark

SmartGen – make your generator *smart*

SmartGen Technology Co., Ltd.

No.28 Jinsuo Road, Zhengzhou, Henan Province, China

Tel: +86-371-67988888/67981888/67992951

+86-371-67981000(overseas)

Fax: +86-371-67992952

Email: [sales@smartgen.cn](mailto:sales@smartgen.cn)

Web: [www.smartgen.com.cn](http://www.smartgen.com.cn)

[www.smartgen.cn](http://www.smartgen.cn)

All rights reserved. No part of this publication may be reproduced in any material form (including photocopying or storing in any medium by electronic means or other) without the written permission of the copyright holder.

Applications for the copyright holder's written permission to reproduce any part of this publication should be addressed to SmartGen Technology at the address above.



Any reference to trademarked product names used within this publication is owned by their respective companies.

SmartGen Technology reserves the right to change the contents of this document without prior notice.

Table 1 - Software Version

Date	Version	Content
2020-04-20	1.0	Original release.
2020-07-08	1.1	Modify the incorrect descriptions, parameter setting range and units.
2021-07-29	1.2	Modify the terminal description (connect Terminal 6 to Terminal 4 instead of Terminal 6 to Terminal 5).
2021-08-23	1.3	Add the language selection configuration parameters, and add language selection description in overview.

Table 2 – Symbolic Description

Sign	Instruction
 NOTE	Highlights an essential element of a procedure to ensure correctness.
 CAUTION!	Indicates a procedure or practice, which, if not strictly observed, could result in damage or destruction of equipment.



## CONTENTS

1	OVERVIEW.....	4
2	PERFORMANCE AND CHARACTERISTICS.....	4
3	SPECIFICATION .....	5
4	PANEL INDICATORS AND TERMINALS DESCRIPTION.....	6
5	SCOPES AND DEFINITIONS OF PROGRAMMABLE PARAMETERS.....	9
6	WARNINGS.....	13
7	OUTPUT CONFIGURATION CONTENTS.....	15
8	FUNCTION DESCRIPTION .....	17
8.1	INSTRUCTION.....	17
8.2	FIXED POWER MODE .....	17
8.3	POWER SHARE MODE.....	17
8.4	TEST MODE.....	17
9	TYPICAL DIAGRAM.....	18
10	CASE DIMENSION.....	19
11	INSTALLATION PRECAUTIONS .....	20
11.1	OUTPUT AND EXPAND RELAYS.....	20
11.2	AC INPUT .....	20
11.3	WITHSTAND VOLTAGE TEST.....	20
12	FAULT FINDING .....	20

SmartGen

## 1 OVERVIEW

**HLS300A Power Share Module** is a piece of upgrade product of HLS300. It is a special design for genset power share. On the basis of pre-set parameters, it can automatically complete power share in the process of genset running. Controller is upgraded to LCD graphic display, optional Chinese and English, control button and reactive power share function are added.

The main function of HLS300A module is to share active power and reactive power proportionally and evenly to each operating genset based on genset capacitance. The module is easy to operate, convenient to install and can be widely used for ship genset and land genset.

## 2 PERFORMANCE AND CHARACTERISTICS

Main characters are as below:

- Suitable for 3-phase 3-wire, single phase 2-wire power systems with frequency 50/60Hz;
- 132x64 LCD display with backlight display, touch-button operations allowing to transfer display or set module running parameters;
- Module running parameters can be set by PC test software; module is connected with PC by USB port in using;
- 10 relay outputs, 2 of which are used for GOV frequency raising and drop to control output, 5 are used for configurable output, 2 are used for -P, P>n% indication outputs, and 1 is used for C/B OPEN output control;
- 1 FIXLOAD mode, 1 UNL unloading, 1 close and 1 AUTO digital input;
- When genset is not working, press UP key longer for 3s in information display interface and it enters test mode, which can test whether LCD display, relay output and panel indicators are normal or not;
- Wide power supply range DC(8~35)V;
- Controller applies 35mm guide rail mounting;
- Modular structure design, pluggable connection terminal, compact structure with easy installation.

### 3 SPECIFICATION

Table 3 – Product Parameters

Parameter	Details
Working Voltage	DC8.0V to DC35.0V continuous
Overall Consumption	2W(Standby mode $\leq$ 1W)
AC Input	AC50V~ AC620 V (ph-ph)
AC Frequency	50Hz/60Hz
Relay Output	6 10A AC250V Volt free outputs 4 5A AC250V Volt free outputs
CT Secondary Current	Rated: 5A
Working Temperature & Humidity	Temperature: (-25~+70) $^{\circ}$ C Humidity: (20~95)%
Storage Temperature	Temperature: (-25~+70) $^{\circ}$ C
Insulation Intensity	Apply AC2.2kV voltage between high voltage terminal and low voltage terminal; The leakage current is not more than 3mA within 1min.
Case Dimensions	161.6mm x 92.94mm x 60.7mm
Weight	0.49kg

#### 4 PANEL INDICATORS AND TERMINALS DESCRIPTION

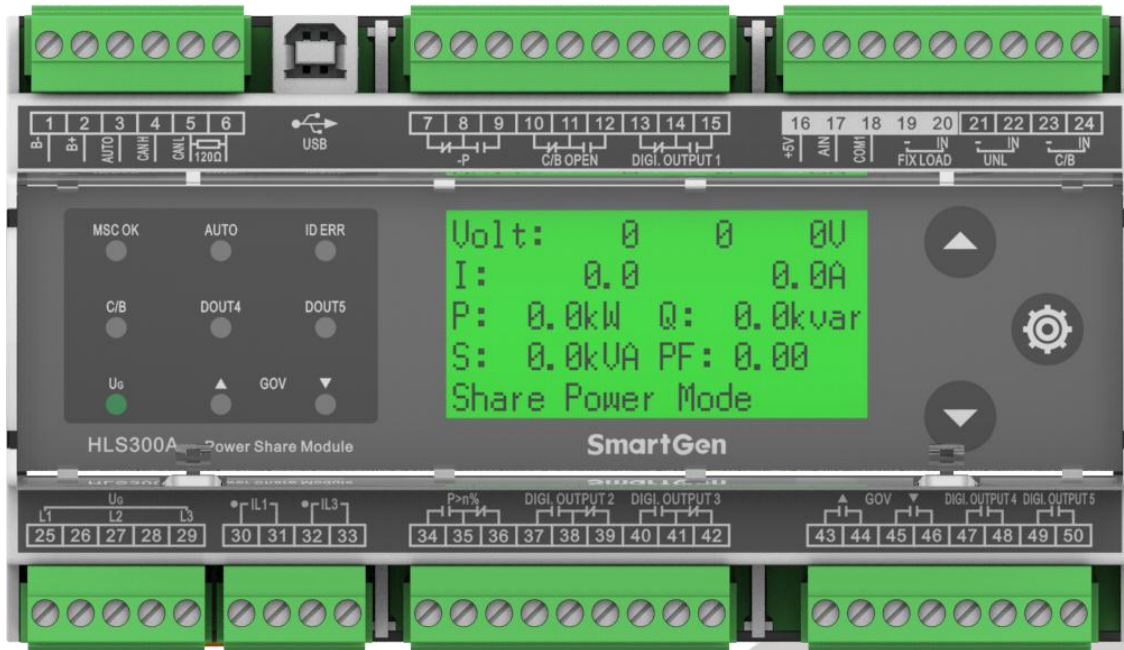

Fig.1 - Mask Drawing

Table 4 - LEDs Definition Description

Indicator	Color	Description	Note
MSC OK	Green	MSC communication normal indicator, and it shall flash once for each data received.	/
AUTO	Green	Illuminated when AUTO input port is active.	/
ID ERR	Red	MSC ID setting wrong indicator; when two modules are the same ID, it is illuminated always.	/
C/B	Green	It is illuminated when main switch close input is active.	/
DOUT4	Green	It is illuminated when DIGI. OUTPUT4 output is high.	/
DOUT5	Green	It is illuminated when DIGI. OUTPUT5 output is high.	/
UG	Green	When Gens is normal, it is illuminated always; when Gens is abnormal, indicator flashes; When no Gens, it is extinguished.	/
GOV+	Green	It is illuminated when speed raise pulse is issued.	/
GOV-	Green	It is illuminated when speed drop pulse is issued.	/



Table 5 - Terminal Description

No.	Function		Cable	Note	
1	B-		1.5mm <sup>2</sup>	Connected with negative of battery.	
2	B+		1.5mm <sup>2</sup>	Connected with positive of battery.	
3	AUTO		0.5mm <sup>2</sup>	Power share is enabled when both C/B input and this input are active.	
4	CANH		0.5mm <sup>2</sup>	MSC communication.	
5	CANL		0.5mm <sup>2</sup>		
6	Terminal Resistor Match			If terminal resistor short connecting with No. 4 terminal is needed, otherwise hung it up.	
7	Reverse Power Output	Normally Close	1.5mm <sup>2</sup>	Output when reverse power has exceeded set value and the delay is over.	Normally open, N/C contactor; Volts free output; 10A Rated
8		COM			
9		Normally Open			
10	Open Output	Normally Close	1.5mm <sup>2</sup>	Output when open.	Normally open, N/C contactor; Volts free output; 10A Rated
11		COM			
12		Normally Open			
13	Digi. Output 1	Normally Close	1.5mm <sup>2</sup>	Configurable digital output port; can be configured to other function output;	Normally open, N/C contactor; Volts free output; 10A Rated
14		COM			
15		Normally Open			
16	+5V		1.0 mm <sup>2</sup>	Power adjustment.	
17	AIN		1.0 mm <sup>2</sup>		
18	COM1		1.0 mm <sup>2</sup>		
19	FIXLOAD	-	1.0mm <sup>2</sup>	Fixed power mode input, active when it is short connected.	
20		IN			
21	UNL	-	1.0mm <sup>2</sup>	Unload input, active when it is short connected.	
22		IN			
23	C/B	-	1.0mm <sup>2</sup>	Main switch close input, active when it is short connected.	
24		IN			
25	L1 Phase Voltage Input		1.0mm <sup>2</sup>	AC input.	
26					
27	L2 Phase Voltage Input		1.0mm <sup>2</sup>		
28					
29	L3 Phase Voltage Input		1.0mm <sup>2</sup>		
30	IL1	CT A Phase Input		1.5mm <sup>2</sup>	Externally connected to secondary coil of current transformer (rated 5A).
31					
32	IL3	CT C Phase Input		1.5mm <sup>2</sup>	Externally connected to secondary coil of current transformer (rated 5A).
33					



No.	Function	Cable	Note	
34	P>n% Output	1.5mm <sup>2</sup>	Output when P>n% Pn (n is set value) and delay is over.	
35				Normally Open
36				COM
37	Digi. Output 2	1.5mm <sup>2</sup>	Configurable digital output port; can be configured to other function output;	
38				Normally Open
39				COM
40	Digi. Output 3	1.5mm <sup>2</sup>	Configurable digital output port; can be configured to other function output;	
41				Normally Open
42				COM
43	Speed Raise Output	1.0mm <sup>2</sup>	Raise speed.	
44				Normally Open
45	Speed Drop Output	1.0mm <sup>2</sup>	Reduce speed.	
46				Normally Open
47	Digi. Output 4	1.0mm <sup>2</sup>	Configurable digital output port; can be configured to other function output;	
48				Normally Open
49	Digi. Output 5	1.0mm <sup>2</sup>	Configurable digital output port; can be configured to other function output;	
50				Normally Open
USB	Used for parameter setting or software upgrade.			

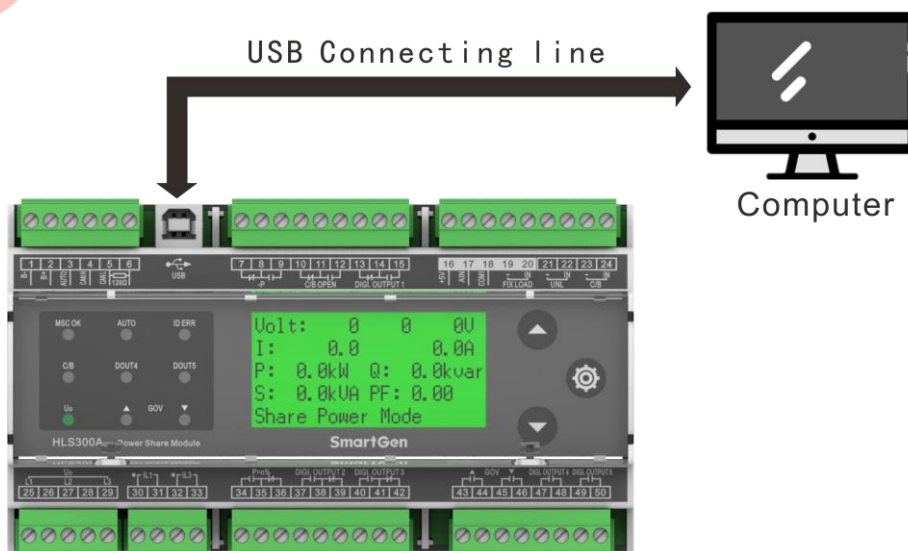

Fig. 2 - PC Programming Connection Type



**NOTE:** About PC programming connection, please connect PC with USB connecting wire. Through the PC software of our company, parameters can be set. Please see Fig. 2.

## 5 SCOPES AND DEFINITIONS OF PROGRAMMABLE PARAMETERS

Table 6 – Module Configurable Parameters

No.	Items	Parameters	Defaults	Description
1	AC System	(0-1)	0	0: 3P3W; 1: 1P2W
2	Rated Voltage	(30-30000) V	400	/
3	Volt Trans.	(0-1)	0	0: Disabled; 1: Enabled
4	Volt Trans. Primary Voltage	(30-30000)V	100	/
5	Volt Trans. Secondary Voltage	(30-1000)V	100	/
6	Over Volt	(0-1)	1	0: Disabled; 1: Enabled
7		(100-120) %	115	Threshold
8		(100-120) %	113	Returned
9		(0-3600) s	3	Delay
10	Under Volt	(0-1)	1	0: Disabled; 1: Enabled
11		(70-100) %	75	Threshold
12		(70-100) %	77	Returned
13		(0-3600) s	3	Delay
14	Over Freq	(0-1)	1	0: Disabled; 1: Enabled
15		(100-120) %	110	Threshold
16		(100-120) %	104	Returned
17		(0-3600) s	3	Delay
18	Under Freq	(0-1)	1	0: Disabled; 1: Enabled
19		(80-100) %	90	Threshold
20		(80-100) %	96	Returned
21		(0-3600) s	3	Delay
22	Loss Of Phase	(0-1)	1	0: Disabled; 1: Enabled
23	Phase Rotation Monitor	(0-1)	1	0: Disabled; 1: Enabled
24	CT Ratio/5	(5-6000)	500	/
25	Full Load Rated Current	(5-6000)A	500	/
26	Rated Active Power	(0-6000)kW	276	/
27	Rated Reactive Power	(0-6000)kvar	207	/
28	Reverse Power Threshold	(0-20)%	10	/
29	Reverse Power Delay	(1-3600)s	3	/
30	Low Power Threshold	(0-20)%	10	/
31	Low Power Delay	(1-3600)s	3	/
32	20% Power Threshold	(0-50)%	20	Total active power/rated active power×100%≤the set value and duration ≥ the corresponding delay value, the output voltage signal is effective if programmable outlet



No.	Items	Parameters	Defaults	Description
				configuration is P<20% .
33	20% Power Delay	(1-3600)s	3	/
34	80% Power Threshold	(0-120)%	80	Total active power/rated active power×100% ≥ the set value and duration ≥ the corresponding delay value, the output voltage signal is effective if programmable outlet configuration is P>80%.
35	80% Power Delay	(1-3600)s	3	/
36	Loss of Excitation Threshold	(0-50)%	20	/
37	Loss of Excitation Delay	(1-3600)s	3	/
38	Unbalance Threshold of Active Share	(0-50)%	15	/
39	Unbalance Delay of Active Share	(1-3600)s	90	/
40	Unbalance Threshold of Reactive Share	(0-50)%	20	/
41	Unbalance Delay of Reactive Share	(1-3600)s	3	/
42	Digi. Output 1 Type	(0-1)	0	0: Normally Open 1: Normally Close
43	Digi. Output 1 Contents	(0-30)	12	Default: Load Transfer Output; Refer to Output Contents.
44	Digi. Output 2 Type	(0-1)	0	0: Normally Open 1: Normally Close
45	Digi. Output 2 Contents	(0-30)	15	Default: P<20% output, Refer to Output Contents.
46	Digi. Output 3 Type	(0-1)	0	0: Normally Open 1: Normally Close
47	Digi. Output 3 Contents	(0-30)	16	Default: Low Power output; Refer to Output Contents.
48	Digi. Output 4 Type	(0-1)	0	0: Normally Open 1: Normally Close
49	Digi. Output 4 Contents	(0-30)	20	Default: Voltage Up output; Refer to Output Contents.
50	Digi. Output 5 Type	(0-1)	0	0: Normally Open 1: Normally Close
51	Digi. Output 5 Contents	(0-30)	21	Default: Voltage Down output; Refer to Output Contents.
52	60Hz Enable	(0-1)	0	0: Disable; 1: Enable
53	Module Address	(1-254)	1	Address of communicating with PC software.
54	Language Selection	(0-1)	0	0: Simplified Chinese; 1: English
55	Module ID	(0-15)	1	Module ID number connected in the same CAN bus.
56	Load Ramp Rate	(0.1-100.0)%/s	3.0	/
57	Load Ramp Rate Delay Percentage	(0.1-40.0)%	10	/



No.	Items	Parameters	Defaults	Description
58	Load Ramp Rate Delay	(0-3600)s	0	/
59	Load Parallel Ramp Minimum	(0-100)%	5	Load value of unload and breaker open;
60	Load Feedback Percentage	(1-100)%	15	Percentage of frequency dividing speed output;
61	Load Feedback Percentage	(1-100)%	15	Percentage of voltage dividing speed output;
62	Open Pulse Output	(1-3600)s	3	/
63	Regulation Limit of Active Power (%)	(0-50.0)%	30.0	/
64	Regulation Limit of Reactive Power (%)	(0-50.0)%	30.0	/
65	Unload Input Pulse Enable	(0-1)	1	There is no need to issue signal continuously during the unload process if this is enabled.
66	Load Share Optimization Enable	(0-1)	1	Adjust to optimize in dead area margin; suitable for high flexibility occasions for governor.
67	Speed Regulating Gain	(0-1000)%	10	Adjust the proportion gain of speed regulating gain.
68	Voltage Governing Gain	(0-1000)%	10	Adjust the proportion gain of voltage governor gain.
69	Failed to Unload and Open Enable	(0-1)	1	0: Disable 1: Enable
70	Failed to Unload Delay	(0-3600)s	30	During the delay, if unload is not up to the target, unload failure alarm occurs; if breaker open enable is set, then it will open.
71	Speed Governor Tn	(25-500)ms	100	The min. lasting time of speed control pulse;
72	Speed Governor T	(0.01-10.00)s	2.00	/
73	Speed Governor Xp	(0-±50)%	50	During the area pulse width is in direct ratio with current active power and rated active power deviation value;
74	Speed Governor Xf	(0-±2.5)Hz	2.5	During the area pulse width is in direct ratio with current frequency and rated frequency deviation value;
75	$\Delta P$	(1-15)%	5	Active power adjusting accuracy; it won't adjust the active power if this has exceeded the set area.
76	$\Delta f$	(0.1-0.3)Hz	0.2	Frequency modulation accuracy; it won't adjust the frequency if



No.	Items	Parameters	Defaults	Description
				frequency has exceeded the set area.
77	Voltage Governor Enable	(0-1)	0	0: Disable 1: Enable
78	Voltage Governor Tn	(25-500)ms	100	The min. lasting time of voltage control pulse;
79	Voltage Governor T	(0.01-10.00)s	2.00	/
80	Voltage Governor Xq	(0 $\pm$ 50)%	50	During the area pulse width is in direct ratio with current reactive power and rated reactive power deviation value;
81	Voltage Governor Xu	(0 $\pm$ 20)%	20	During the area pulse width is in direct ratio with current voltage and rated voltage deviation value;
82	Voltage Governor $\Delta q$	(1-15)%	5	Reactive power adjusting accuracy; it won't adjust the reactive power if this has exceeded the set area.
83	Voltage Governor $\Delta u$	(0.1-15.0)%	2.0	Frequency modulation accuracy; it won't adjust the voltage if frequency has exceeded the set area.

**NOTE:** IDs of modules which are connected to the same CAN bus cannot be the same.

## 6 WARNINGS

When controller detects warning signals, it issues warning alarm signal and LCD displays warning alarm type.

Table 7 - Warnings

No.	Warning Type	Description
1	Gens Over Voltage	When controller detects Gens Voltage/Rated voltage $\times 100\% \geq$ threshold of over voltage setting and lasting time $\geq$ delay value of over voltage setting, it issues warning signal, meanwhile LCD displays Gens Over Voltage warning.
2	Gens Under Voltage	When controller detects Gens Voltage/Rated voltage $\times 100\% \geq$ threshold of under voltage setting and lasting time $\geq$ delay value of under voltage setting, it issues warning signal, meanwhile LCD displays Gens Under Voltage warning.
3	Gens Over Frequency	When controller detects Gens frequency/Rated frequency $\times 100\% \geq$ threshold of over frequency setting and lasting time $\geq$ delay value of over frequency setting, it issues warning signal, meanwhile LCD displays Gens Over Frequency warning.
4	Gens Under Frequency	When controller detects Gens frequency /Rated frequency $\times 100\% \geq$ threshold of under frequency setting and lasting time $\geq$ delay value of under frequency setting, it issues warning signal, meanwhile LCD displays Gens Under Frequency warning.
5	Reverse Power	When controller detects total active power $< 0$ , absolute value/rated active power $\times 100\% \geq$ reverse power threshold and lasting time $\geq$ reverse power delay value, it issues warning signal, meanwhile LCD displays reverse power warning.
6	Reverse Phase Sequence	When controller detects Gens Ub phase $>$ Gens Uc phase and lasting time $\geq 3s$ , it issues warning alarms, meanwhile LCD displays Reverse Phase Sequence Wrong warning.
7	Loss of Phase	When controller detects one phase is lost, it issues warning alarms, meanwhile LCD displays loss of phase warning.
8	Loss of Excitation	When controller detects current reactive power percentage $< 0$ , absolute value $\geq$ loss of excitation value and lasting time $\geq$ loss of excitation delay, controller issues warning signal, meanwhile LCD displays Loss of Excitation warning.
9	Active Unbalance Share	When controller detects active unbalance percentage $\geq$ active share unbalance threshold and lasting time $\geq$ active share unbalance delay value, it issues warning alarm signal, meanwhile LCD displays active power share unbalance warning.
10	Reactive Unbalance Share	When controller detects reactive unbalance percentage $\geq$ reactive share unbalance threshold and lasting time $\geq$ reactive share unbalance delay value, it issues warning alarm signal, meanwhile LCD displays reactive power share unbalance warning.
11	Failed To Unload	When unloading input is active, after failed to unload delay, current active power percentage $>$ minimum loading percentage, it issues



No.	Warning Type	Description
		warning alarm signal, meanwhile LCD displays failed to unload warning.
12	MSC ID Set Wrong	When controller detects module IDs in the same CAN bus are the same, it issues warning signal, meanwhile LCD displays MSC ID set wrong.

SmartGen

## 7 OUTPUT CONFIGURATION CONTENTS

Table 8 – Output Contents

No.	Output Contents	Description
00	Not Used	/
01	Over Voltage	When Gens voltage/rated voltage x100% $\geq$ over voltage threshold and lasting time $\geq$ over voltage delay, then over voltage is active.
02	Under Voltage	When Gens voltage/rated voltage x100% $\leq$ under voltage threshold and lasting time $\geq$ under voltage delay, then under voltage is active.
03	Over Frequency	When Gens frequency/rated frequency x100% $\geq$ over frequency threshold and lasting time $\geq$ over frequency delay, then over frequency is active.
04	Under Frequency	When Gens frequency/rated frequency x100% $\leq$ under frequency threshold and lasting time $\geq$ under frequency delay, then under frequency is active.
05	Reverse Power	When total active power $< 0$ , absolute value/rated active power x100% $\geq$ reverse power threshold and lasting time $\geq$ reverse power delay, then reverse power is active.
06	Reverse Phase Sequence	When Gens Ub phase $>$ Gens Uc phase and lasting time $\geq 3s$ , then reverse phase sequence is active.
07	Loss of Phase	One phase among 3 phases is lost, and this is loss of phase.
08	Loss of Excitation	When current reactive power percentage $< 0$ , absolute value $\geq$ loss of excitation threshold, and lasting time $\geq$ loss of excitation delay, loss of excitation is active.
09	Unbalance of Active Power Share	When unbalance percentage of active power $\geq$ unbalance threshold of active share and lasting time $\geq$ unbalance delay of active share, unbalance of active power share is judged.
10	Unbalance of Reactive Power Share	When unbalance percentage of reactive power $\geq$ unbalance threshold of reactive share and lasting time $\geq$ unbalance delay of reactive share, unbalance of reactive share is judged.
11	Breaker Open Output	/
12	UNLOADING Output	Loading transfer output is active in the unloading process.
13	Common Alarm Output	When any alarm in Table 7 occurs, common alarm is considered.
14	P $>80\%$ Output	When total active power/rated active power x100% $\geq 80\%$ power threshold and lasting time $\geq 80\%$ power delay, P $>80\%$ is active.
15	P $<20\%$ Output	When total active power/rated active power x100% $\leq 20\%$ power threshold and lasting time $\geq 20\%$ power delay value, P $<20\%$ is active.
16	LOW-P Output	When total active power/rated active power x100% $\leq$ low power threshold and lasting time $\geq$ low power delay value, low power is active.
17	MSC ID Wrong	When module IDs in the same CAN bus are the same, then MSC ID wrong is judged.



No.	Output Contents	Description
18	Speed Raise Output	/
19	Speed Drop Output	/
20	Voltage Raise Output	/
21	Voltage Drop Output	/
22	Reserved	/
23	Reserved	/

SmartGen



## 8 FUNCTION DESCRIPTION

### 8.1 INSTRUCTION

The function of HLS300A Power Share Module is to proportionally share active power and reactive power to each operating genset according to genset capacitance. When "FIXLOAD" input is active, the module works in fixed power mode; otherwise the module works in power share mode. Press UP button for 3s in information display interface, and it will enter into test mode, which is used to test relay output and indicator status.

### 8.2 FIXED POWER MODE

Target active power can be set via the external device connected with terminal 16, 17, 18. When close input and fixed power input are active, the module will adjust present power to target power and active power will stabilize in the area between  $\Delta f$  and  $\Delta P$ , while reactive power will stabilize in the area between  $\Delta u$  and  $\Delta q$ .

### 8.3 POWER SHARE MODE

Multiple modules are connected with each other via CAN bus and operate in power share mode together. Target power is an average of present power sum of these modules. When close input is active, the module will adjust present power to target power and active power will stabilize in the area between  $\Delta f$  and  $\Delta P$ , while reactive power will stabilize in the area between  $\Delta u$  and  $\Delta q$ .

### 8.4 TEST MODE

When Generator is not working, press UP button for 3s in information display interface, and the module will enter into test mode. For each time press UP key, there will be one relay outputting and one indicator illuminating. When relay output is completed (for each time only one relay output and one indicator light on), module will exit from test mode. When module is in test mode, if no key is pressed in 20 seconds, then module will exit from test mode automatically.

**▲NOTE:** Test mode is prohibited to enter for module when generator is working.

## 9 TYPICAL DIAGRAM

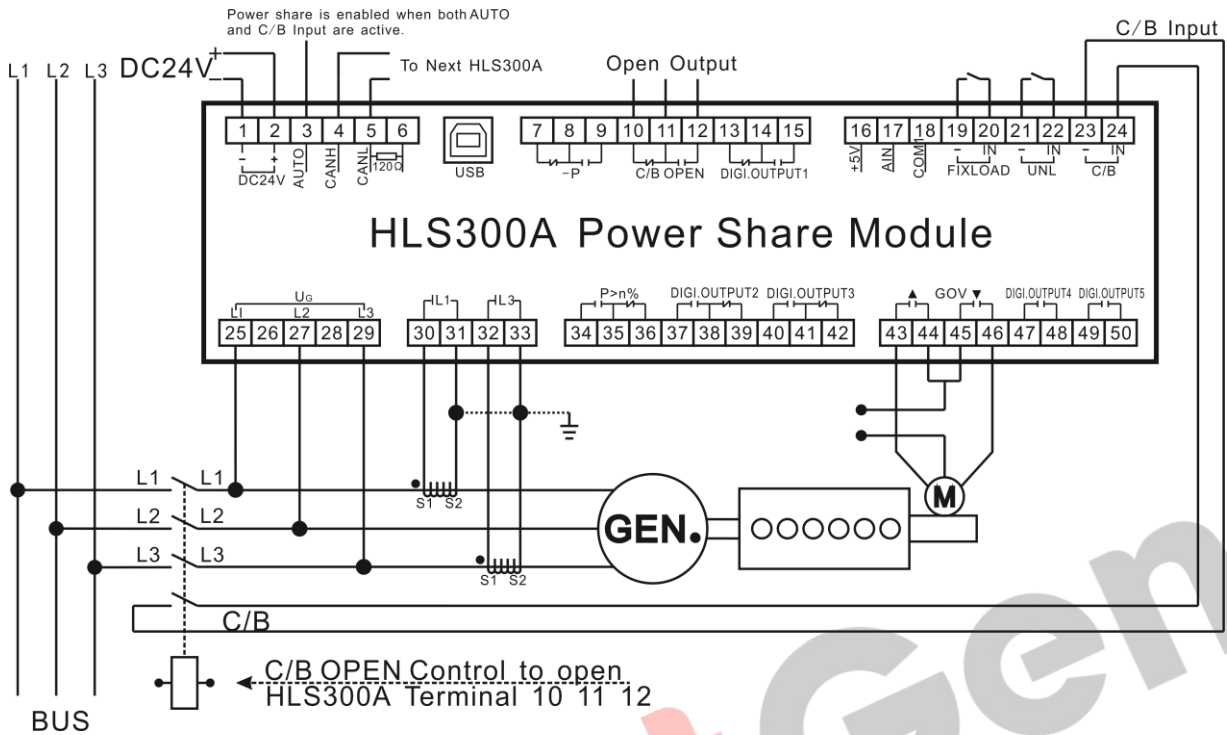

Fig.3 - HLS300A 3Phase 3Wire Typical Application

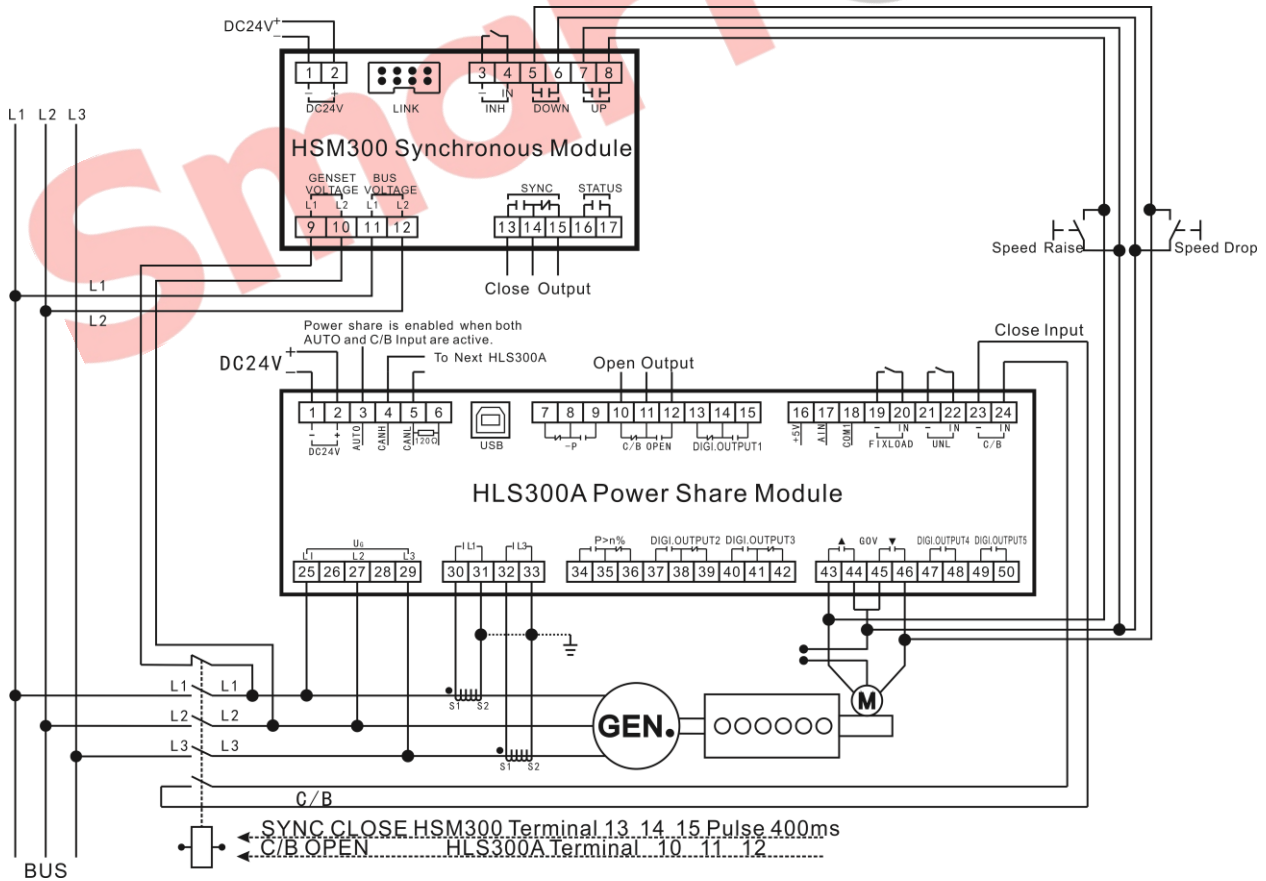

Fig.4 - HSM300-HLS300A 3Phase 3Wire Typical Application

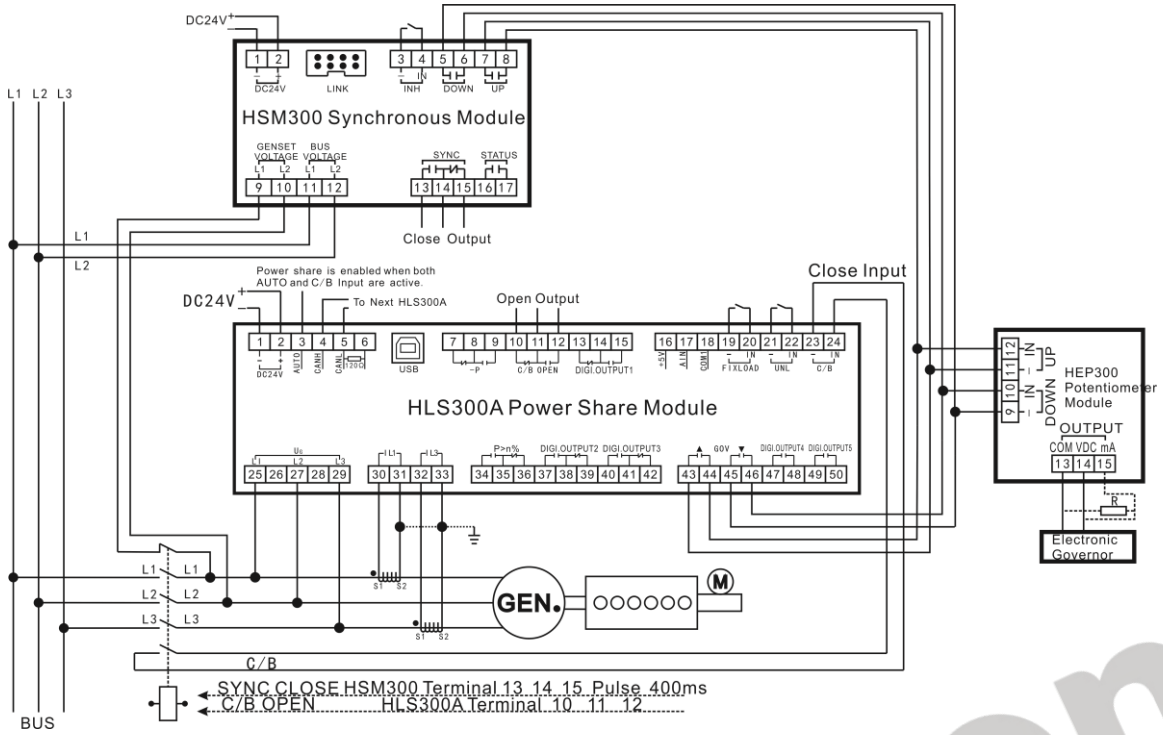

Fig.5 - HSM300-HLS300A-HEP300 3Phase 3Wire Typical Application

## 10 CASE DIMENSION



图1 Fig. 6 – Overall Dimensions (Unit: mm)

## 11 INSTALLATION PRECAUTIONS

### 11.1 OUTPUT AND EXPAND RELAYS

All outputs are relay contact output type. If it needs to expand the relays, please add freewheel diode to both ends of expand relay's coils (when coils of relay have DC current) or, add resistance-capacitance return circuit (when coils of relay have AC current), in order to prevent disturbance for controller or other equipments.

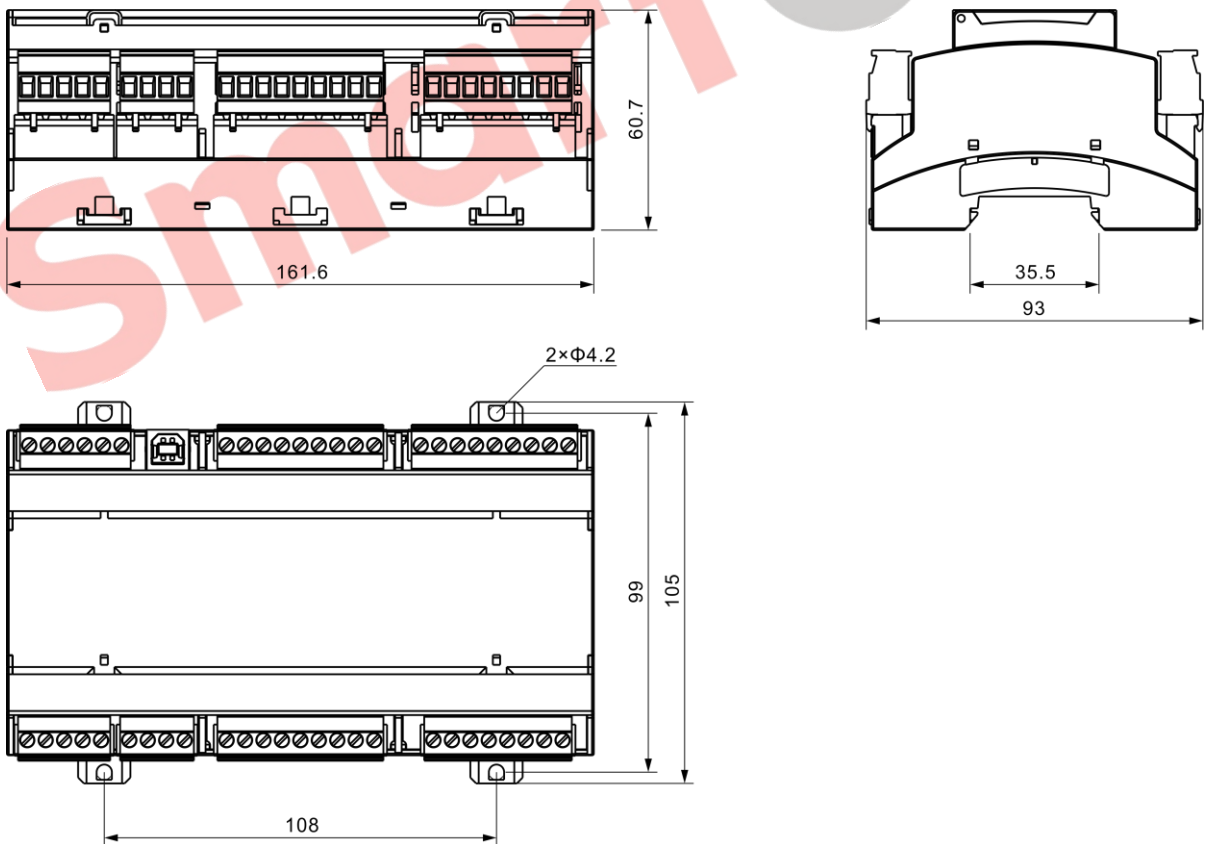
### 11.2 AC INPUT

Current input must be connected to outside current transformer. And the current transformer's secondary side current must be 5A. Meanwhile the phases of CT and input voltage must be correct, otherwise the sampling current and active power may be incorrect.

**▲ NOTE:** When there is load current, transformer's secondary side is prohibited to have open circuit.

### 11.3 WITHSTAND VOLTAGE TEST

**▲ CAUTION!** When controller has been installed in control panel, if it needs doing the high voltage test, please disconnect all terminal connections, in order to prevent high voltage entering controller and damaging it.

## 12 FAULT FINDING

The followings are the common faults and troubleshooting methods during the use process of our company controllers. If other unsolvable faults occur, please contact our company.

Table 9 - Fault Findings

Fault Symptom	Possible Measures
Controller no response with power on	Check controller connection wirings;
Speed and voltage cannot be regulated.	Check speed regulator and voltage governor connecting wires and check whether voltage regulation output is enabled.
Unbalanced power share	Check voltage governor and speed regulator wirings; Check whether breaker close feedback input and AUTO input are normal or not;
Circular high and low distribution of gensets in parallel network; (Leisurely car)	Dead area of power distribution setting is too minimum; Speed and voltage governor parameter configurations make output flexibility too high; Speed and voltage governor flexibility is too high.