

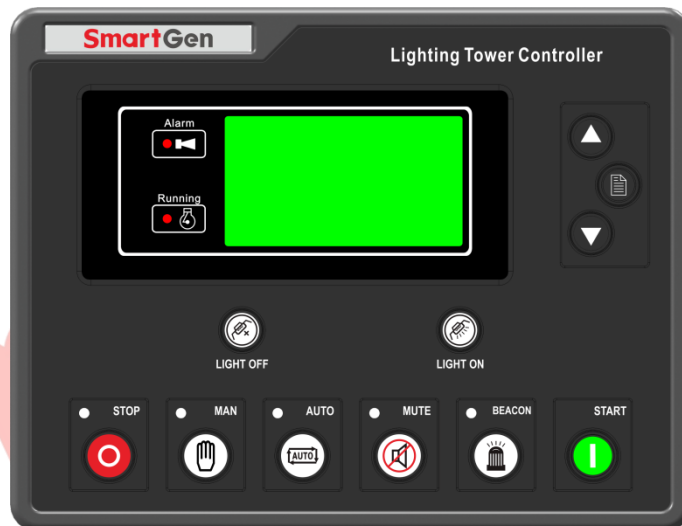

**SmartGen**  
ideas for power

**ALC700 SERIES  
(ALC704/ALC708)  
LIGHTING TOWER CONTROLLER  
USER MANUAL**



**ZHENGZHOU SMARTGEN TECHNOLOGY CO.,LTD**



Chinese trademark

**SmartGen** English trademark

SmartGen — make your generator *smart*

SmartGen Technology Co., Ltd.

No.28 Jinsuo Road

Zhengzhou

Henan Province

P. R. China

Tel: 0086-371-67988888/67981888

0086-371-67991553/67992951

0086-371-67981000(overseas)

Fax: 0086-371-67992952

Web: [www.smartgen.com.cn](http://www.smartgen.com.cn)

[www.smartgen.cn](http://www.smartgen.cn)

Email: [sales@smartgen.cn](mailto:sales@smartgen.cn)

All rights reserved. No part of this publication may be reproduced in any material form (including photocopying or storing in any medium by electronic means or other) without the written permission of the copyright holder.

Applications for the copyright holder's written permission to reproduce any part of this publication should be addressed to SmartGen Technology at the address above.

Any reference to trademarked product names used within this publication is owned by their respective companies.



SmartGen Technology reserves the right to change the contents of this document without prior notice.

#### Version history

Date	Version	Contents
2013-05-08	1.0	Original release
2013-12-06	1.1	Modify some functions.
2014-07-29	1.2	Modify some terminals description.
2015-07-01	1.3	Modify light control relay output description.
2018-03-02	1.4	Modify "8.4 ENABLE DEFINITION CONTENTS" description.

It is only suit for ALC700 series controller.

Symbols description,

Symbol	Instruction
 NOTE	Highlights an essential element of a procedure to ensure correctness.
 CAUTION	Indicates a procedure or practice, which, if not strictly observed, could result in damage or destruction of equipment.
 WARNING	Indicates a procedure or practice, which could result in injury to personnel or loss of life if not followed correctly.

SmartGen

# CONTENTS

1	OVERVIEW.....	6
2	MODULES COMPARISON.....	6
3	PERFORMANCE AND CHARACTERISTICS.....	7
4	SPECIFICATION .....	9
5	OPERATION.....	10
5.1	PUSHBUTTONS.....	10
5.2	LCD DISPLAY.....	11
5.3	SCHEDULED START/STOP .....	13
5.4	SUNRISE/SUNSET MODE.....	15
5.5	AUTO SMS MODE.....	17
5.6	AUTO SMS SUNRISE/SUNSET MODE .....	19
5.7	REMOTE START MODE .....	21
5.8	MANUAL START/STOP.....	23
6	PROTECTIONS .....	25
6.1	WARNING ALARMS.....	25
6.2	SHUTDOWN ALARMS .....	27
6.3	TRIP AND STOP ALARMS .....	29
7	WIRING CONNECTION.....	30
8	SCOPES AND DEFINITIONS OF PROGRAMMABLE PARAMETERS.....	33
8.1	CONTENTS AND SCOPES OF PARAMETERS.....	33
8.2	ENABLE DEFINITION OF PROGRAMMABLE OUTPUT PORT 1-4.....	36
8.3	ENABLE DEFINITION OF PROGRAMMABLE INPUT PORT 1-4.....	39
8.4	ENABLE DEFINITION CONTENTS .....	39
8.5	SENSOR SELECTION.....	40
8.6	SENSORS SETTING .....	41
8.7	OVER CURRENT ACTION .....	42
8.8	CONDITIONS OF CRANK DINSCONNECT SELECTION .....	42
8.9	LIGHT INPUTS SETTINGS.....	43
8.10	BATTERY LOW VOLT WORK MODE.....	43
8.11	TIMER MODE SELECT .....	43
8.12	SMS (ORDER AND REPLY).....	44
8.13	SUNRISE/SET SET .....	44
9	PARAMETERS SETTING.....	45
10	EVENT LOG .....	46
11	COMMISSIONING .....	47
12	TYPICAL WIRING DIAGRAMS.....	48

---

13	INSTALLATION .....	49
13.1	BATTERY VOLTAGE INPUT .....	49
13.2	SPEED SENSOR INPUT .....	49
13.3	OUTPUT AND EXPAND RELAYS .....	50
13.4	AC INPUT .....	50
13.5	DC CURRENT INPUT .....	50
13.6	WITHSTAND VOLTAGE TEST .....	50
14	FAULT FINDING .....	51
15	WHOLE SET OF PRODUCT .....	51

SmartGen

## 1 OVERVIEW

**ALC700** series controllers are used for automation and monitor control systems of single light tower unit to achieve scheduled start/stop, sunrise and sunset start/stop, SMS message remote start/stop as well as start/stop genset via remote input port.

**ALC700** series controllers can be used for turning on and off the flashlights of the light tower in proper order and is compatible with both AC and DC light tower sets. The modules are digital, smart and networked and enjoy precise data measurement, alarm protection as well as remote control, remote measuring and remote communication functions.

**ALC700** series controllers adopt micro-processor technology and combine automation control function with flashlights control function into one product. They have LCD display, selectable Chinese/English languages interface, modular design, compact structure and simple connections. They can be widely used in all types of automatic light tower set with compact structure, advanced circuits, and high reliability.

## 2 MODULES COMPARISON

Items	ALC704	ALC708
Total Number of Controlled Light Tower	4	8
DC Detection	Yes	Yes
AC Detection	Yes	Yes
Digital Input	8	12
Relay Output	10	14
Scheduled Start	Yes	Yes
Auto SMS Mode	No	Yes
Auto SMS Sunrise/Sunset Mode	No	Yes
Remote Start	Yes	Yes
Event log	Yes	Yes
USB	Yes	Yes
RS485	No	Yes
High-precision Clock	Yes	Yes

### NOTE:

The user manual takes ALC708 as its template while ALC704 has relatively simple features. You can get all information about ALC704 just reference this document.

### 3 PERFORMANCE AND CHARACTERISTICS

- Based on microprocessor, fitted with LCD screen with graphic icons and backlight, selectable Chinese/English languages interface and silicon panel and pushbuttons;
- Be compatible with both AC and DC light tower sets.
- True RMS value detection. Collects and shows electrical parameters, water temperature, oil pressure, fuel level and other parameters of diesel light tower set.

3-phase/Single phase Generator Voltage

3-phase/Single phase Load Current

Generator Frequency

Active Power/Reactive Power/Power Factor

Engine Speed

Engine Temperature

Engine Oil Pressure

Fuel Level

Flexible Sensor

Starter Battery Voltage/Charger D+ Terminal Voltage

DC Voltage/Current/Power Detection

- Real-time clock and real-time calendar functions allow scheduled start/stop (everyday), sunrise and sunset start/stop light tower set; moreover, scheduled start time, running duration time, sunrise time and sunset time can be set by users as their wish.
- SMS message function (GSM modem must be fitted). When failure occurs, controller will send short messages automatically to max. 5 telephone numbers. Besides, users can remote start/stop light tower set via SMS message.
- Remote start function. Set arbitrary input port as "Remote Start Input" and controller enters into remote start mode, then users can remote start/stop light tower set by remote close/open input port.
- Manual start/stop control of light tower set and manual on/off control of flashlight.
- Standard RS485 communication port enables remote control, remote measuring, and remote communication via ModBus protocol.
- Standard USB communication port makes it easier to communicate with PC and faster to be programmed.
- Flashlight indicator control function;

- Accumulative total run time and total electric energy functions make convenient for users to regular maintain and survey fuel consumption;
- Scheduled start time, SMS telephone number and various delays can be set on the spot and also comes with password protection in case of laypeople disoperation.
- ALC708 controller can control up to 8 flashlights and the feedback indicator were be fitted on the panel. In addition, the turn on interval time between two lights can be set by users.
- 99 pieces of event logs can be circularly stored and inquired on the spot; also can be print or be inquired via PC.
- More kinds of curves of temperature, oil pressure, fuel level can be used directly and users can select “User Configured” sensor curves for unknown engine sensor ;
- Widely power supply range DC(8~35)V, suitable to different starting battery voltage environment;
- Modular design, pluggable terminal, built-in mounting, compact structure with easy installation;

















## 4 SPECIFICATION

Parameter	Details
Working Voltage	DC8. 0V to 35. 0V, uninterruptible power supply
Overall Consumption	<5W (Standby mode: ≤2W)
Voltage Input:	
3 Phase 4 Wire	AC 20V - 360V (ph-N)
3 Phase 3 Wire	AC 30V - 600V (ph-ph)
Single Phase 2 Wire	AC 20V - 360V (ph-N)
2 Phase 3 Wire	AC 20V - 360V (ph-N)
DC	DC 0V - 75V (ph-N)
Alternator Frequency	50Hz/60Hz
Speed Sensor Voltage	1. 0 V to 24 V (RMS)
Speed Sensor Frequency	Maximum 10,000 Hz
Start Relay Output	8A DC28V power supply output
Fuel Relay Output	8A DC28V power supply output
Configurable Relay Output 1	8A DC28V power supply output
Configurable Relay Output 2	8A DC28V power supply output
Configurable Relay Output 3	8A DC28V power supply output
Configurable Relay Output 4	8A AC250V free volt output
Light Control Relay Output 1~4	8A AC250V free volt output (total output current: 8A) If 1~4 is all used, the maximum current of each light is 2A.
Light Control Relay Output 5~8	8A AC250V free volt output (total output current: 8A) If 1~4 is all used, the maximum current of each light is 2A.
Case Dimensions	197 mm x 152 mm x 47 mm
Panel Cutout	186mm x 141mm
CT Secondary Current	Rated: 5A
DC Current Input	Hall sensor's secondary side current: (4~20)mA
Working Conditions	Temperature: (-25~+70)°C Relative Humidity: (20~93)%RH
Storage Conditions	Temperature:(-25~+70)°C
Protection Level	IP55. If water-proof gasket is inserted between panel and enclosure.
Insulation Intensity	Apply AC2.2kV voltage between high voltage terminal and low voltage terminal; The leakage current is not more than 3mA within 1min.
Weight	0.71kg





## 5 OPERATION

### 5.1 PUSHBUTTONS

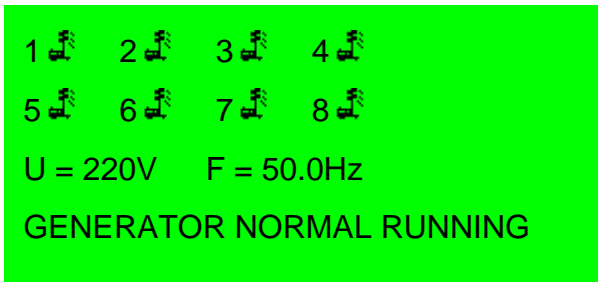
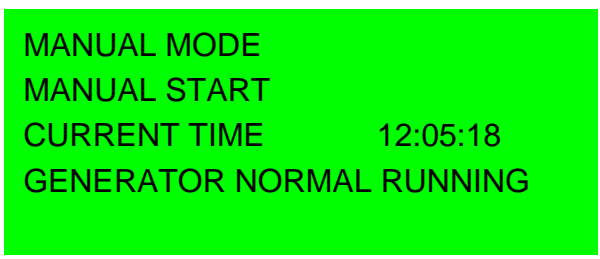
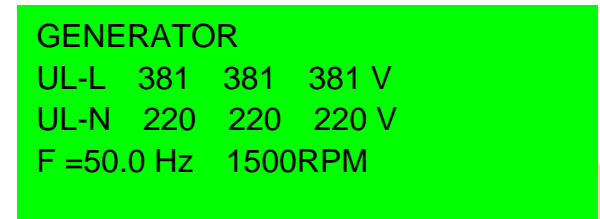
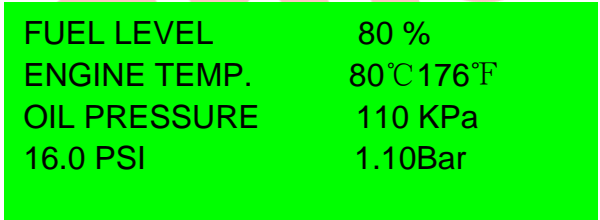
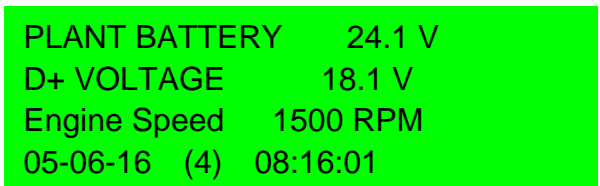
Icon	Key	Description
	Stop/Reset	Stop running light tower set; Reset alarm when failure occurs; Lamp test in stop mode (press at least 3 seconds);
	Manual Mode	Press this key and controller enters in <b>Manual</b> mode.
	Auto Mode	Press this key and controller enters into auto start mode select interface; use   to select mode and press  again to confirm the selection.
	Mute	If alarm occurs, pressing the button can remove this alarm, and the indicator will light on; press the button again will reset alarm and the indicator will light off. If alarm occurs again in mute status, the controller will remove mute status automatically.
	Flashlight	Can control flashlight to switch on or off.
	Start	Start lighting tower set in Manual mode.
	Light Off	During normal running in manual mode, turn off one light for each pressing. Press this key for a long time can turn off the light in proper sequence according to preset time.
	Light On	During normal running in manual mode, turn on one light for each pressing. Press this key for a long time can turn on the light in proper sequence according to preset time.
	Menu / Confirm “√”	Press this key to enter into menu interface. In parameter setting interface press this key to right shift cursor and confirm the setting at the last bit.
	Down/Config. “-”	1) Screen scroll; 2) Down cursor and decrease value in setting menu.
	Up / Config. “+”	1) Screen scroll; 2) Up cursor and increase value in setting menu.

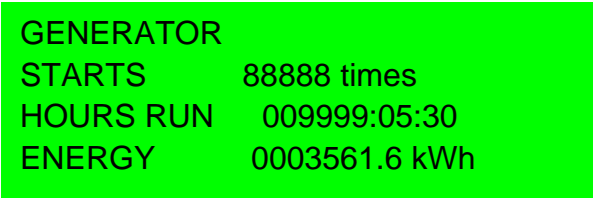
## 5.2 LCD DISPLAY

Display	Description
 <p>1  2  3  4             5  6  7  8             U = 220V F = 50.0Hz            GENERATOR NORMAL RUNNING</p>	<p>First screen display all lights status, average voltage , generator frequency, generator running status and alarm information.</p> <p>Light On: </p> <p>Light Off: </p>
 <p>MANUAL MODE            MANUAL START            CURRENT TIME 12:05:18            GENERATOR NORMAL RUNNING</p>	<p>Second screen display: Generator running status, current time, alarm information.</p>
 <p>GENERATOR            UL-L 381 381 381 V            UL-N 220 220 220 V            F =50.0 Hz 1500RPM</p>	<p>Press  button</p> <p>The screen display generator line voltage(L1-L2, L2-L3, L3-L1), phase voltage(L1、L2、L3), frequency and engine speed.</p> <p>DC light tower set without this page.</p>
 <p>FUEL LEVEL 80 %            ENGINE TEMP. 80°C176°F            OIL PRESSURE 110 KPa            16.0 PSI 1.10Bar</p>	<p>Press  button</p> <p>The screen display generator fuel level, engine temperature, oil pressure, flexible sensor information.</p> <p>There is no sensor information when flexible sensor select “Not used” or “Digital closed” or “Digital open”.</p> <p>The screen display “++++” when sensor is open circuit.</p>
 <p>PLANT BATTERY 24.1 V            D+ VOLTAGE 18.1 V            Engine Speed 1500 RPM            05-06-16 (4) 08:16:01</p>	<p>Press  button</p> <p>The screen display battery voltage, charger voltage, engine speed and current time (the number in the parentheses is week information).</p>

Display	Description
 <p>           GENERATOR            STARTS        88888 times            HOURS RUN    009999:05:30            ENERGY      0003561.6 kWh         </p>	<p>Press  button</p> <p>The screen display accumulated start times, accumulated energy, accumulated run time (HH: MM: SS).</p>
 <p>           LOAD            CURRENT    500 500 500 A            POWER      330kW 330kVA            Cosφ = 1.00    0.0kVar         </p>	<p>Press  button</p> <p>The screen display load current, total active power, total apparent power, total reactive power and power factor</p> <p>The screen display voltage, current and power when DC current is fitted.</p>

**NOTE:** Pressing   can scroll screen circularly.

### 5.3 SCHEDULED START/STOP









- A. Press , its indicator light on, and controller enters **Auto** mode. Meanwhile, the panel display **Auto Mode Select** (Fig 1); Press  and  to select **01 Auto Timer Mode** and press  or  to confirm (Fig 2); Press  and  to select **01 Timer Start** and press  or  to confirm (Fig 3).

Fig 1

```
AUTO MODE SELECT
01 AUTO TIMER MODE
02 AUTO SMS MODE
03 SUNRISE/SUNSET MODE
```

Fig 2

```
AUTO TIMER MODE
01 TIMER START
02 TIMER STOP
03 TIMER SET
```

Fig 3

```
AUTO TIMER MODE
START TIME      16:28:00
CURRENT TIME    12:05:18
GENERATOR AT REST
```

- B. When there are 10s left from start time, audible alarm relay is active (if configured). When start time is up and start remaining time is more than 0s, light tower set begin cranking and flashlight is twinkling (if configured). Stop delay time will be displayed on the first line (Fig 4).

Fig 4

```
STOP DELAY      10:10:59
START TIME      16:28:00
CURRENT TIME    16:28:00
CRANKING        5s
```

- C. If generator voltage and frequency has reached on-load requirements (Voltage $\geq$ on-load voltage and frequency $\geq$ on-load frequency), all the lights will illuminate in proper order and the illumination interval delay is 2s (can be set as 1~300s). (Fig 5,6)

Fig 5

```
STOP DELAY      10:07:42
START TIME      16:28:00
CURRENT TIME    16:32:18
2# LIGHT ON     09s
```

Fig 6

STOP DELAY	09:06:02
START TIME	16:28:00
CURRENT TIME	16:33:58
GENERATOR NORMAL RUNNING	

- D. When “stop delay” time is 00:00:00 or repeat above-mentioned A procedure, select 02 TIMER STOP (01 TIMER START must be reselect if another time scheduled start is needed), then 1#~8# lights will off in proper order and the extinguishing interval delay can be set as 1s~300s. The light tower set begin stopping when all the lights off. (Picture 7,8)

Fig 7

STOP DELAY	00:00:00
START TIME	16:28:00
CURRENT TIME	23:32:18
7# LIGHT OFF	09s

Fig 8

AUTO TIMER MODE	
START TIME	16:28:00
CURRENT TIME	23:33:58
COOLING TIME	29s

- ▲NOTE: The auto timer mode will be canceled automatically when select other auto start mode!

## 5.4 SUNRISE/SUNSET MODE

If the city information haven't been set when select this mode, users should connect PC and ALC700 controller using USB or RS485 communication line and set the city information first.

The procedures as following:

Open test software—edit configuration—set sunrise/sunset—select city/user-defined city (longitude, latitude and time zone) — download the configuration









- A. Press , its indicator light on, and controller enters **Auto** mode. Meanwhile, the panel display **Auto Mode Select** (Fig 1); Press  and  to select **03 Sunrise/Sunset Mode** and press  or  to confirm (Fig 2); Press  and  to select **01 Sunrise/Sunset Start** and press  or  to confirm (Fig 3).

Fig 1

```
AUTO MODE SELECT
01 AUTO TIMER MODE
02 AUTO SMS MODE
03 SUNRISE/SUNSET MODE
```

Fig 2

```
SUNRISE/SET ACTION
01 SUNRISE/SUNSET START
02 SUNRISE/SUNSET STOP
```

Fig 3

```
SUNRISE/SET ACTION
START TIME      17:26:00
CURRENT TIME    12:05:18
GENERATOR AT REST
```

- B. When there are 10s left from start time (controller's current time can be set via utility computer software), audible alarm relay is active (if configured). When start time is up, light tower set begin cranking and flashlight is twinkling (if configured). Stop delay will be displayed on the first line (Fig 4).

Fig 4

```
STOP DELAY      07:25:00
START TIME      17:26:00
CURRENT TIME    17:26:02
CRANKING        5s
```

- C. If generator voltage and frequency has reached on-load requirements (Voltage  $\geq$  on-load voltage and frequency  $\geq$  on-load frequency), all the lights will illuminate in proper order and the illumination interval delay is 2s (can be set as 1~300s). (Fig 5,6)

Fig 5

```

STOP DELAY      07:25:00
START TIME      17:26:00
CURRENT TIME    17:26:15
2# OUTPUT DELAY 09s
    
```

Fig 6

```

STOP DELAY      07:25:00
START TIME      17:26:00
CURRENT TIME    17:27:20
GENERATOR NORMAL RUNNING
    
```

- D. When "Current Time" is 07:25:00(controller's current time can be set via upper computer software), then 1#~8# lights will off in proper order and the extinguishing interval delay can be set as 1s~300s. The light tower set begin stopping when all the lights off. (Fig 7,8)

Fig 7

```

STOP DELAY      07:25:00
START TIME      17:26:00
CURRENT TIME    07:25:00
7# OFF DELAY    09s
    
```

Fig 8

```

SUNRISE/SET ACTION
START TIME      17:26:00
CURRENT TIME    07:27:00
COOLING TIME    29s
    
```

- ▲NOTE: The Sunrise/Sunset mode will be canceled automatically when select other auto start mode!



## 5.5 AUTO SMS MODE





- A. Press , its indicator light on, and controller enters **Auto** mode. Meanwhile, the panel display **Auto Mode Select** (Fig 1); Press  and  to select **02 Auto SMS Mode** and press  or  to confirm (Fig 2).

Fig 1

```
AUTO MODE SELECT
01 AUTO TIMER MODE
02 AUTO SMS MODE
03 SUNRISE/SUNSET MODE
```

Fig 2

```
AUTO DIAL-UP MODE
WAIT SMS COMMAND
CURRENT TIME    12:05:18
GENERATOR AT REST
```

- B. When SMS message module receives the start command, light tower set begin cranking and flashlight is twinkling (if configured). Stop delay will be displayed twinklingly on the first line of the second screen. (Fig 3).

Fig 3

```
AUTO DIAL-UP MODE
SMS START
CURRENT TIME    12:05:18
CRANKING        5s
```

- C. If generator voltage and frequency has reached on-load requirements (Voltage  $\geq$  on-load voltage and frequency  $\geq$  on-load frequency), all the lights will illuminate in proper order and the illumination interval delay is 2s (can be set as 1~300s). (Fig 4,5)

Fig 4

```
AUTO DIAL-UP MODE
SMS START
CURRENT TIME    16:32:18
2# OFF DELAY    09s
```

Fig 5

```
AUTO DIAL-UP MODE
SMS START
CURRENT TIME    16:33:58
GENERATOR NORMAL RUNNING
```

D. When SMS message module receives the stop command, the 1#~8# lights will off in proper order and the extinguishing interval delay can be set as 1s~300s. The light tower set begin stopping when all the lights off. (Fig 6,7)

Fig 6

```
AUTO DIAL-UP MODE
SMS STOP
CURRENT TIME      23:32:18
7# OFF DELAY      09s
```

Fig 7

```
AUTO TIMER MODE
SMS STOP
CURRENT TIME      23:33:58
COOLING TIME      29s
```

▲NOTE: The auto SMS mode will be canceled automatically when select other auto start mode!



## 5.6 AUTO SMS SUNRISE/SUNSET MODE





- A. Press , its indicator light on, and controller enters **Auto** mode. Meanwhile, the panel display **Auto Mode Select** (Fig 1); Press  and  to select **02 Auto SMS Mode** and press  or  to confirm (Fig 2). The status of SMS message module is normal if there is signal display on the second line.

Fig 1

```
AUTO MODE SELECT
1 AUTO TIMER MODE
2 AUTO SMS MODE
3 SUNRISE/SUNSET MODE
```

Fig 2

```
AUTO DIAL-UP MODE
WAIT SMS COMMAND
CURRENT TIME 12:05:18
GENERATOR AT REST
```

- B. When controller receives start order (**SMS SUNRISE/SET START**) correctly (Fig 3), it will reply message: **SMS SUNRISE/SET START OK**. The telephone number which sends start order message should be set via test software and downloaded into controller.

Fig 3

```
SUNRISE/SET ACTION
START TIME 17:26:00
CURRENT TIME 12:05:18
GENERATOR AT REST
```

- C. When there are 10s left from start time (controller's current time can be set via utility computer software), audible alarm relay is active (if configured). When start time is up, light tower set begin cranking and flashlight is twinkling (if configured). Stop delay will be displayed on the first line of the second screen (Fig 4).

Fig 4

```
STOP TIME 07:25:00
START TIME 17:26:00
CURRENT TIME 16:28:00
CRANKING 5s
```

D. If generator voltage and frequency has reached on-load requirements (Voltage  $\geq$  on-load voltage and frequency  $\geq$  on-load frequency), all the lights will illuminate in proper order and the illumination interval delay is 2s (can be set as 1~300s). (Fig 5,6)

**Fig 5**

```

STOP TIME      07:25:00
START TIME     17:26:00
CURRENT TIME   17:26:00
2# OUTPUT DELAY 09s
    
```

**Fig 6**

```

STOP TIME      07:25:00
START TIME     17:26:00
CURRENT TIME   17:27:20
GENERATOR NORMAL RUNNING
    
```

E. When “Current Time” is 07:25:00(controller’s current time can be set via utility computer software), then 1#~8# lights will off in proper order and the extinguishing interval delay can be set as 1s~300s. The light tower set begin stopping when all the lights off. (Fig 7,8)

**Fig 7**

```

STOP TIME      07:25:00
START TIME     17:26:00
CURRENT TIME   07:25:00
7# OFF DELAY  09s
    
```

**Fig 8**

```

SUNRISE/SET ACTION
START TIME     17:26:00
CURRENT TIME   07:27:00
COOLING TIME   29s
    
```

**▲NOTE:** The auto SMS sunrise/sunset mode will be canceled automatically when select other auto start mode !

## 5.7 REMOTE START MODE

- A. Set arbitrary input port as “Remote Start”. Press , its indicator light on, and controller enters Auto Mode. Meanwhile, the panel display **Auto Mode Select** (Fig 1); Press  and  to select **04 REMOTE START** and press  or  to confirm (Fig 2).

Fig 1

```
AUTO MODE SELECT
2 AUTO SMS MODE
3 SUNRISE/SUNSET MODE
4 REMOTE START
```

Fig 2

```
REMOTE START MODE
WAIT REMOTE START
CURRENT TIME 12:05:18
GENERATOR AT REST
```

- B. When remote start input port is active (input port can be set via utility computer software), remote start delay begins and audible alarm relay is active (if configured). When remote start delay is over and remote start signal is active, light tower set begin cranking and flashlight is twinkling (if configured). (Fig 3, 4).

Fig 3

```
REMOTE START MODE
START DELAY 10s
CURRENT TIME 16:32:18
GENERATOR NORMAL RUNNING
```

Fig 4

```
REMOTE START MODE
REMOTE START
CURRENT TIME 16:32:18
GENERATOR NORMAL RUNNING
```

- C. If generator voltage and frequency has reached on-load requirements (Voltage  $\geq$  on-load voltage and frequency  $\geq$  on-load frequency), all the lights will illuminate in proper order and the illumination interval delay is 2s (can be set as 1~300s). (Fig 5)

Fig 5

```
REMOTE START MODE
REMOTE START
CURRENT TIME 16:33:58
1# OFF
```

- D. When remote start input port is inactive, remote stop delay begins (same as start delay); when stop delay is over, 1#~8# lights will off in proper order and the extinguishing interval delay can be set as 1s~300s. The light tower set begin stopping when all the lights off. (Fig 6,7,8)

Fig 6

```

REMOTE START MODE
STOP DELAY      10s
CURRENT TIME    23:32:18
GENERATOR NORMAL RUNNING
  
```

Fig 7

```

REMOTE START MODE
WAIT REMOTE START
CURRENT TIME    23:32:18
8# OFF
  
```

Fig 8

```

REMOTE START MODE
WAIT REMOTE START
CURRENT TIME    23:33:58
COOLING        29s
  
```

## 5.8 MANUAL START/STOP



- A. Press , its indicator light on, and controller enters Manual Mode (Picture 1). Press , light tower set begin cranking (Fig 2).

Fig 1

```
MANUAL MODE
WAIT MANUAL START
CURRENT TIME      12:05:18
GENERATOR AT REST
```

Fig 2

```
MANUAL MODE
MANUAL START
CURRENT TIME      12:05:18
CRANKING          5s
```





- B. Press , the light relay will activate (if configured) while deactivate by pressing  again.
- C. When warming up delay is over, in addition, generator voltage and frequency has reached on-load requirements (Voltage  $\geq$  on-load voltage and frequency  $\geq$  on-load frequency), 1#~8# lights will illuminate in proper order by pressing  button while off in proper order by pressing  button. (Fig 3,4)

Fig 3

```
MANUAL MODE
MANUAL START
CURRENT TIME      16:32:18
GENERATOR NORMAL
```

Fig 4

```
MANUAL MODE
MANUAL START
CURRENT TIME      16:33:58
1# OFF
```



D. Press , 1#~8# lights will off in proper order and the extinguishing interval delay can be set as 1s~300s. The light tower set begin stopping when all the lights off. Press  again during this procedure will lead to all lights off at the same time and ETS status of controller (Fig 5,6)

Fig 5

```
MANUAL MODE
MANUAL STOP
CURRENT TIME      23:32:18
8# OFF
```

Fig 6

```
MANUAL MODE
MANUAL STOP
CURRENT TIME      23:33:58
COOLING           29s
```

SmartGen



## 6 PROTECTIONS

### 6.1 WARNING ALARMS

Warnings are not shutdown alarms and do not affect the operation of the genset. Alarm information will be displayed on the LCD.

Warning alarms types are as follows:

No.	Type	Description
1	High Temp. Warn	When controller detects the temperature is higher than the set value, it will send warning signal and the corresponding alarm information will be displayed on the LCD.
2	Low OP Warn	When controller detects the oil pressure is lower than the set value, it will send warning signal and the corresponding alarm information will be displayed on the LCD.
3	Over Speed	When controller detects the speed is higher than the set value, it will send warning signal and the corresponding alarm information will be displayed on the LCD.
4	Under Speed	When controller detects the speed is lower than the set value, it will send warning signal and the corresponding alarm information will be displayed on the LCD.
5	Loss of Speed Signal	When controller detects the speed is 0, it will send warning signal and the corresponding alarm information will be displayed on the LCD.
6	Over Frequency	When controller detects the generator frequency is higher than the set value, it will send warning signal and the corresponding alarm information will be displayed on the LCD.
7	Under Frequency	When controller detects the generator frequency is lower than the set value, it will send warning signal and the corresponding alarm information will be displayed on the LCD.
8	Over Voltage	When controller detects the generator voltage is higher than the set value, it will send warning signal and the corresponding alarm information will be displayed on the LCD.
9	Under Voltage	When controller detects the generator voltage is lower than the set value, it will send warning signal and the corresponding alarm information will be displayed on the LCD.
10	Over Current	When controller detects the generator current is higher than the set value, it will send warning signal and the corresponding alarm information will be displayed on the LCD.

No.	Type	Description
11	Fail to Stop	If generator output electricity after the “ETS solenoid delay/ fail to stop delay” is over, it will send warning signal and the corresponding alarm information will be displayed on the LCD.
12	Low Fuel Level	When controller detects the fuel lever is lower than the set value, it will send warning signal and the corresponding alarm information will be displayed on the LCD.
13	Charge Alt Fail	When controller detects the charger voltage is lower than the set value, it will send warning signal and the corresponding alarm information will be displayed on the LCD.
14	Battery Under Voltage	When controller detects the battery voltage is lower than the set value, it will send warning signal and the corresponding alarm information will be displayed on the LCD.
15	Battery Over Voltage	When controller detects the battery voltage is higher than the set value, it will send warning signal and the corresponding alarm information will be displayed on the LCD.
17	Flexible Sensor Low	When controller detects the sensor value is lower than the minimum set value, it will send warning signal and the corresponding alarm information will be displayed on the LCD. If the sensor name is configured by users as xxx, then “xxx low” warn will be displayed on the LCD.
18	Flexible Sensor High	When controller detects the sensor value is higher than the maximum set value, it will send warning signal and the corresponding alarm information will be displayed on the LCD. If the sensor name is configured by users as xxx, then “xxx high” warn will be displayed on the LCD.
16	Aux. input 1-4 Warn	When the controller detects auxiliary input ports 1-4 warning, it will send warning alarm signal and the corresponding alarm information will be displayed on the LCD. If the input port name is configured by users as xxx, then “xxx warn” will be displayed on the LCD.
<p> NOTE: The warning types of Aux. input are active only when they are configured by users.</p>		

## 6.2 SHUTDOWN ALARMS

When controller detects shutdown alarm, it will send signal to turn off #1~#8 lights and shuts down generator.

Shutdown alarms as following:

No.	Type	Description
1	Emergency Stop	When controller detects emergency stop signal, it will send a shutdown signal and the corresponding alarm information will be displayed on the LCD.
2	High Temp. Shutdown	When controller detects the temperature is higher than the set value, it will send a shutdown signal and the corresponding alarm information will be displayed on the LCD.
3	Low OP Shutdown	When controller detects the oil pressure is lower than the set value, it will send a shutdown signal and the corresponding alarm information will be displayed on the LCD.
4	Over Speed	When controller detects the generator speed is higher than the set value, it will send a shutdown signal and the corresponding alarm information will be displayed on the LCD.
5	Under Speed	When controller detects the generator speed is lower than the set value, it will send a shutdown signal and the corresponding alarm information will be displayed on the LCD.
6	Loss of Speed Signal	When controller detects the generator speed is 0, it will send a shutdown signal and the corresponding alarm information will be displayed on the LCD.
7	Over Frequency	When controller detects the generator frequency is higher than the set value, it will send a shutdown signal and the corresponding alarm information will be displayed on the LCD.
8	Under Frequency	When controller detects the generator frequency is lower than the set value, it will send a shutdown signal and the corresponding alarm information will be displayed on the LCD.
9	Over Voltage	When controller detects the generator voltage is higher than the set value, it will send a shutdown signal and the corresponding alarm information will be displayed on the LCD.
10	Under Voltage	When controller detects the generator voltage is lower than the set value, it will send a shutdown signal and the corresponding alarm information will be displayed on the LCD.
11	Over Current	When controller detects the current is higher than the set value, it will send a shutdown signal and the corresponding alarm information will be displayed on the LCD.
12	Fail To Start	If genset start failure within setting of start times, it will send a shutdown signal and the corresponding alarm information will be displayed on the LCD.

No.	Type	Description
13	Pressure Sensor Open	When controller detects the oil pressure sensor is open circuit, it will send shutdown signal and the corresponding alarm information will be displayed on the LCD.
14	Temp. Sensor Open	When controller detects the temperature sensor is open circuit, it will send a shutdown signal and the corresponding alarm information will be displayed on the LCD.
15	Low Fuel Level	When controller detects the fuel lever is lower than the set value, it will send shutdown signal and the corresponding alarm information will be displayed on the LCD.
16	Flexible Sensor Open	When controller detects the sensor is open circuit, it will send a shutdown signal and the corresponding alarm information will be displayed on the LCD. If the sensor name is configured by users as xxx, then "xxx open" will be displayed on the LCD.
17	Flexible Sensor High	When controller detects the sensor value is higher than the maximum set value, it will send shutdown signal and the corresponding alarm information will be displayed on the LCD. If the sensor name is configured by users as xxx, then "xxx high" will be displayed on the LCD.
18	Flexible Sensor Low	When controller detects the sensor value is lower than the minimum set value, it will send shutdown signal and the corresponding alarm information will be displayed on the LCD. If the sensor name is configured by users as xxx, then "xxx low" will be displayed on the LCD.
19	Aux. input 1-4	When the controller detects auxiliary input ports 1-4 shutdown alarms, it will send shutdown alarm signal and the corresponding alarm information will be displayed on the LCD. If the input port name is configured by users as xxx, then "xxx shutdown" will be displayed on the LCD.
<p><b>▲NOTE:</b> The shutdown alarm types of Aux. input are active only when they are configured by users.</p>		

### 6.3 TRIP AND STOP ALARMS

When the controller detects trip and stop signal, it will send signal to turn off #1 ~ #8 lights and then generator is cooling down and stopped.

Shutdown alarms as following:

NO.	Type	Detection range	Description
1	Over Current	Always active	When controller detects the current is higher than the set value, it will send a “trip and stop” signal and the corresponding alarm information will be displayed on the LCD.
2	Aux. input 1-4	User-defined	When the controller detects auxiliary input ports 1-4 trip alarms, it will send a “trip and stop” alarm signal and the corresponding alarm information will be displayed on the LCD. If the input port name is configured by users as xxx, then “xxx trip and stop” will be displayed on the LCD.

▲NOTE: The trip and stop alarm types of Aux. input are active only when they are configured by users.

## 7 WIRING CONNECTION

ALC700 controller's rear as following:

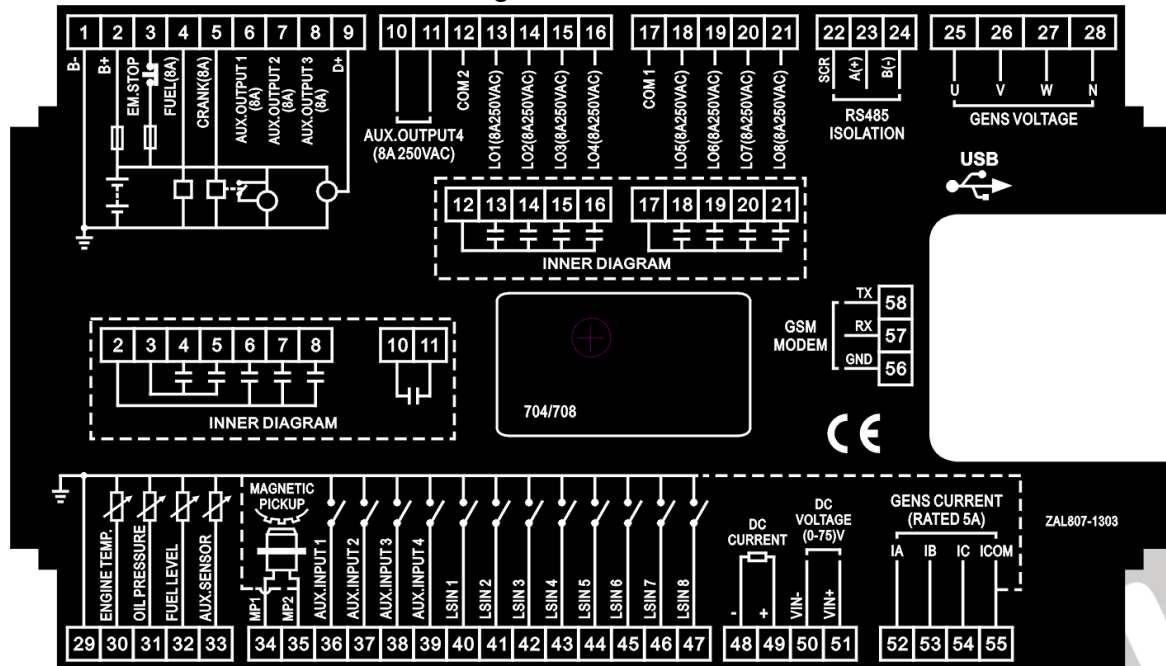

Description of terminal connection:

NO.	Functions	Cable Size	Remark
1	DC input B-	2.5 mm <sup>2</sup>	Connected with negative of starter battery.
2	DC input B+	2.5 mm <sup>2</sup>	Connected with positive of starter battery. 20A fuse is recommended.
3	Emergency stop	1.5 mm <sup>2</sup>	Connected with DC voltage via emergency stop button. Max. 30A fuse is recommended.
4	Fuel relay	1.5 mm <sup>2</sup>	DC voltage is supplied by 3 point, rated 8A.
5	Start Relay	1.5 mm <sup>2</sup>	DC voltage is supplied by 3 point, rated 8A.
6	Aux. output 1	1.5 mm <sup>2</sup>	B+ output, rated 8A.
7	Aux. output 2	1.5 mm <sup>2</sup>	
8	Aux. output 3	1.5 mm <sup>2</sup>	
9	Charger (D+)	1.0 mm <sup>2</sup>	Connected with charger's D+ (WL) terminals. Ground connection is not allowed.
10	Aux. output 4	1.5 mm <sup>2</sup>	Normally open voltage free outputs, rated 8A.
11		1.5 mm <sup>2</sup>	
12	1#-4# COM	2.5 mm <sup>2</sup>	Total output current: 8A If 1~4 is all used, the maximum current of each light is 2A.
13	1# Light Output	1.5 mm <sup>2</sup>	
14	2# Light Output	1.5 mm <sup>2</sup>	
15	3# Light Output	1.5 mm <sup>2</sup>	

NO.	Functions	Cable Size	Remark
16	4# Light Output	1.5 mm <sup>2</sup>	Total output current: 8A If 1~4 is all used, the maximum current of each light is 2A.
17	5#-8# COM	2.5 mm <sup>2</sup>	
18	5# Light Output	1.5 mm <sup>2</sup>	
19	6# Light Output	1.5 mm <sup>2</sup>	
20	7# Light Output	1.5 mm <sup>2</sup>	
21	8# Light Output	1.5 mm <sup>2</sup>	
22	RS485 SCR	0.5 mm <sup>2</sup>	RS485 communication ports Communicate with PC.
23	RS485 A	0.5 mm <sup>2</sup>	
24	RS485 B	0.5 mm <sup>2</sup>	
25	Light tower set A-phase voltage sensing input	1.0 mm <sup>2</sup>	Connected to A-phase of light tower set (2A fuse is recommended).
26	Light tower set B-phase voltage sensing input	1.0 mm <sup>2</sup>	Connected to B-phase of light tower set (2A fuse is recommended).
27	Light tower set C-phase voltage sensing input	1.0 mm <sup>2</sup>	Connected to C-phase of light tower set (2A fuse is recommended).
28	Light tower set N-wire input	1.0 mm <sup>2</sup>	Connected to N-wire of light tower set.
29	Sensor COM	1.0 mm <sup>2</sup>	Public terminal of sensor, connect to enclosure or negative of starter battery.
30	Engine Temp.	1.0 mm <sup>2</sup>	Engine temperature sensor input. Externally connected to resistor sensor.
31	Oil pressure	1.0 mm <sup>2</sup>	Oil pressure sensor input. Externally connected to resistor sensor.
32	Fuel level	1.0 mm <sup>2</sup>	Fuel level sensor input. Externally connected to resistor sensor.
33	Aux. Sensor	1.0 mm <sup>2</sup>	Flexible sensor input. Externally connected to resistor sensor.
34	MP+	1.0 mm <sup>2</sup>	Connect to positive of magnetic pickup.
35	MP-	1.0 mm <sup>2</sup>	Connect to negative of magnetic pickup; (B-) has already connected internal.
36	Aux. input 1	1.0 mm <sup>2</sup>	Digital input; connect B- is active.
37	Aux. input 2	1.0 mm <sup>2</sup>	Digital input; connect B- is active.
38	Aux. input 3	1.0 mm <sup>2</sup>	Digital input; connect B- is active.
39	Aux. input 4	1.0 mm <sup>2</sup>	Digital input; connect B- is active.
40	1# Light Input	1.0 mm <sup>2</sup>	1# light control feedback input; connect B- is active.
41	2# Light Input	1.0 mm <sup>2</sup>	2# light control feedback input; connect B- is active.
42	3# Light Input	1.0 mm <sup>2</sup>	3# light control feedback input; connect

NO.	Functions	Cable Size	Remark
			B- is active.
43	4# Light Input	1.0 mm <sup>2</sup>	4# light control feedback input; connect B- is active.
44	5# Light Input	1.0 mm <sup>2</sup>	5# light control feedback input; connect B- is active.
45	6# Light Input	1.0 mm <sup>2</sup>	6# light control feedback input; connect B- is active.
46	7# Light Input	1.0 mm <sup>2</sup>	7# light control feedback input; connect B- is active.
47	8# Light Input	1.0 mm <sup>2</sup>	8# light control feedback input; connect B- is active.
48	DC Current -	1.0 mm <sup>2</sup>	Connect to the output port of Hall DC 4-20mA sensor(DC Generator current)
49	DC Current +	1.0 mm <sup>2</sup>	
50	DC Voltage -	1.0 mm <sup>2</sup>	
51	DC Voltage +	1.0 mm <sup>2</sup>	
52	CT A-phase sensing input	2.5 mm <sup>2</sup>	Externally connected to secondary coil of current transformer (rated 5A).
53	CT B-phase sensing input	2.5 mm <sup>2</sup>	Externally connected to secondary coil of current transformer (rated 5A).
54	CT C-phase sensing input	2.5 mm <sup>2</sup>	Externally connected to secondary coil of current transformer (rated 5A).
55	CT COM	2.5 mm <sup>2</sup>	Current transformer's common port ; Connected with negative of starter battery.
56	Controller GND	0.5 mm <sup>2</sup>	Communicate with GSM MODEM
57	Controller RXD	0.5 mm <sup>2</sup>	
58	Controller TXD	0.5 mm <sup>2</sup>	
USB	USB Port	0.5 mm <sup>2</sup>	Communicate with communication software of PC.



## 8 SCOPES AND DEFINITIONS OF PROGRAMMABLE PARAMETERS

### 8.1 CONTENTS AND SCOPES OF PARAMETERS

#### Form 1

Parameters		DET Range	Default	Remarks
01 TIMER MODE SELECT		0-3	0	0 Daily 1 Weekly 2 Monthly 3 Custom Week
02 START DAY	Daily Weekly Monthly Custom Week	Null Monday ~Sunday 1-31 Null	0	
03 Timer Start	Start Time Run Duration	00:00-23:59 00:00-23:59	18:30 12:00	Start Time HH:MM Run Duration HH:MM
04 CUSTOM SUNDAY	Start Time Run Duration	00:00-23:59 00:00-23:59	18:30 12:00	Start Time HH:MM Run Duration HH:MM
05 CUSTOM MONDAY	Start Time Run Duration	00:00-23:59 00:00-23:59	18:30 12:00	Start Time HH:MM Run Duration HH:MM
06 CUSTOM TUESDAY	Start Time Run Duration	00:00-23:59 00:00-23:59	18:30 12:00	Start Time HH:MM Run Duration HH:MM
07 CUSTOM WEDNESDAY	Start Time Run Duration	00:00-23:59 00:00-23:59	18:30 12:00	Start Time HH:MM Run Duration HH:MM
08 CUSTOM THURSDAY	Start Time Run Duration	00:00-23:59 00:00-23:59	18:30 12:00	Start Time HH:MM Run Duration HH:MM
09 CUSTOM FRIDAY	Start Time Run Duration	00:00-23:59 00:00-23:59	18:30 12:00	Start Time HH:MM Run Duration HH:MM
10 CUSTOM SATURDAY	Start Time Run Duration	00:00-23:59 00:00-23:59	18:30 12:00	Start Time HH:MM Run Duration HH:MM
11 Telephone Number 1				Please add national code before the telephone number(e.g. China 0086)
12 Telephone Number 2				
13 Telephone Number 3		maximum 16 bits		
14 Language		(0-1)	0	0: Simplified Chinese 1: English
15 Sunset Start Delay		(-60)-(60)min	0	Postponement Start Time (plus-minus)
16 Sunrise Stop Delay		(-60)-(60)min	0	Postponement Stop Time (plus-minus)

**Other parameters configuration (only configured by software via PC)**

Parameters	Default
Start Delay	5s
Pre-heat Delay	0s
Cranking Time	5s
Crank Rest Time	10s
Safety On Delay	10s
Start Idle Time	10s
Warming Up Time	30s
Cooling Time	60s
Stop Idle Time	10s
ETS Solenoid Hold	20s
Fail to Stop Delay	30s
Over Speed Time	2s
Light Output Interval Time	2s
Total Number of Controlled Light Tower	8
Audible Alarm Output Delay	30s
AC Generator Select	Yes
Poles	4
Magnetic Pickup	Yes
AC System	3 Phase 4 Wire
Fast Onload	No
Start Attempts	3
PT	No
Fuel Pump Control	No
Engine Temperature Sensor	VDO 120 degrees C
Oil Pressure Sensor	VDO 10 bar
Fuel Level Sensor	VDO ohm range (10-180)
Flexible Sensor	Not Used
Low Oil Pressure Shutdown	103Kpa
High Temperature Shutdown	95°C
Low Fuel Level Warn	10%
Input Port 1	Remote start input
Input Port 2	Content: High Temperature; Active Type: Closed to active; Active Action: Shutdown; Arming: From safety on
Input Port 3	Content: Low Fuel Level; Active Type: Closed to active; Active Action: Shutdown; Arming: From safety on
Input Port 4	Content: Low Water Level; Active Type: Closed to active; Active Action: Warn; Arming: Always
Output Port 1	Preheat during preheat timer; Normally open output

Parameters	Default
Output Port 2	Common alarm; Normally open output
Output Port 3	Flashlight output; Normally open output
Output Port 4	Audible alarm output; Normally open output
Input Port 1 Custom Delay	2s
Input Port 2 Custom Delay	2s
Input Port 3 Custom Delay	2s
Input Port 4 Custom Delay	2s
Generator Under Frequency Warn	42.0Hz
Generator Under Frequency Shut	40.0Hz
Generator Onload Frequency	45.0Hz
Generator Over Frequency Warn	55.0Hz
Generator Over Frequency Return	52.0Hz
Generator Over Frequency Shut	57.0Hz
Generator Under Voltage Warn	196V
Generator Under Voltage Shut	185V
Generator Onload Voltage	207V
Generator Over Voltage Warn	264V
Generator Over Voltage Return	253V
Generator Over Voltage Shut	273V
Over Current Percentage	100%
Delay Ratio	36
Over Current Action	Trip and stop
Crank Disconnect Generator Frequency	15Hz
Crank Disconnect Engine Speed	450RPM
Crank Disconnect Oil Pressure	Not Used
Oil Pressure Detection During Cranking	No
Battery Low Volt Work Mode	Invalid
Battery Low Volt Set Value	80%
Battery Low Volt Run Time	40min
Light Inputs Settings	Feedback input

## 8.2 ENABLE DEFINITION OF PROGRAMMABLE OUTPUT PORT 1-4

No.	Type	Description
0	Not Used	
1	Air Flap	Action when over speed shutdown and emergence stop. It also can close the air inflow to stop the engine as soon as possible.
2	Audible Alarm	Action when common alarm output and the output delay can be set by users.
3	Battery High Volts	Action when battery's over voltage warning alarm.
4	Battery Low Volts	Action when battery's under voltage warning alarm.
5	Reserved	
6	Reserved	
7	Reserved	
8	Start Relay	Action when genset is cranking and disconnect when start successfully.
9	Fuel Relay	Action when genset is cranking and disconnect in fail to stop delay.
10	Auto Start Mode	In auto start mode, action when start and disconnect when stop.
11	Charge Alt Fail	Action when charge failure warning alarms.
12	Reserved	
13	Reserved	
14	Reserved	
15	Reserved	
16	Over/Under Freq. Shut	Action when generator over/under frequency shutdown.
17	Over/Under Freq. Warn	Action when generator over/under frequency warn.
18	Over/Under Volt. Shut	Action when generator over/under voltage shutdown.
19	Over/Under Volt. Warn	Action when generator over/under voltage warn.
20	Common Alarm	Action when genset common warning, common shutdown, common trips alarm.
21	Common Trip Alarm	Action when common trips alarm.
22	Common Shutdown	Action when common shutdown alarm.
23	Common Warn Alarm	Action when common warning alarm.
24	High Temp Warn	Action when hi-temperature warning. (engine temperature sensor)
25	High Temp Shutdown	Action when hi-temperature shutdown alarm (engine temperature sensor).
26	Cooling Timer in Progress	Action when cooling delay is in ongoing.
27	Reserved	
28	Aux Input 1 Active	Action when input port 1 is active.
29	Aux Input 2 Active	Action when input port 2 is active
30	Aux Input 3 Active	Action when input port 3 is active
31	Aux Input 4 Active	Action when input port 4 is active

No.	Type	Description
32	Reserved	
33	Reserved	
34	Emergency Stop	Action when emergency stop alarm.
35	ETS Control	Action during ETS delay.
36	Failed To Start	Action when failed start alarm.
37	Fuel Pump Control	It is controlled by fuel pump of level sensor's limited threshold.
38	Generator Available	Action in period of generator normal running to hi-speed cooling.
39	Gen over frequency Warn	Action when generator over frequency warning.
40	Gen over frequency Shut	Action when generator over frequency shutdown alarm.
41	Gen Over Volt Warn	Action when generator over voltage warning.
42	Gen Over Volt Shut	Action when generator over voltage shutdown.
43	Gen Under Freq. Warn	Action when generator low frequency warning.
44	Gen Under Freq. Shut	Action when generator low frequency shutdown.
45	Gen Under Volt. Warn	Action when generator low voltage warning.
46	Gen Under Volt. Shut	Action when generator low voltage shutdown.
47	Louver Control	Action when genset cranking and disconnect when genset stopped completely.
48	Low Level Warn	Action when controller has low oil level alarm. (fuel level sensor) .
49	Loss of Speed Signal	Action when detected engine speed value is 0 during normal running period.
50	Flexible Sensor Low Shutdown	Action when flexible sensor low shutdown.
51	Flexible Sensor Low Warn	Action when flexible sensor low warns.
52	Flexible Sensor High Warn	Action when flexible sensor high warns.
53	Flexible Sensor High Shutdown	Action when flexible sensor high shutdown.
54	Flexible Sensor Open	Action when flexible sensor is open circuit.
55	Low OP Warn	Action when low oil pressure warns (oil pressure sensor).
56	Low OP Shutdown	Action when low oil pressure shutdown (oil pressure sensor).
57	OP Sensor Open	Action when oil pressure sensor is open circuit.
58	Reserved	
59	Reserved	
60	Reserved	
61	Reserved	
62	Over Current Warn	Action when over current warns.
63	Over Current Trip	Action when over current trip.
64	Over Speed Warn	Action when over speed warns.

No.	Type	Description
65	Over Speed Shutdown	Action when over speed shutdown alarm.
66	Preheat (during preheat timer)	Action in period of preheat delay to cranking.
67	Preheat (until end of crank)	Action in period of preheat delay to the end of cranking delay.
68	Preheat (until end of warm timer)	Action in period of preheat delay to the end of warming up delay.
69	Preheat (until end of safety on)	Action in period of preheat delay to the end of safety on delay.
70	Reserved	
71	Reserved	
72	Auto Mode	Action in Auto mode.
73	Manual Mode	Action in Manual mode.
74	Stop Mode	Action in stop mode.
75	Under Speed Warn	Action when over speed warns.
76	Under Speed Shutdown	Action when over speed shutdown alarm.
77	Reserved	
78	Idle/High Speed Control	Action during “cranking---start idle” period and “stop idle --- fail to stop” period.
79	Oil Pre-supply	Actions in period of cranking to safety on.
80	Raise Speed	Action in warming up delay.
81	Excite Generator	Output in start period. If there is no generator frequency during hi-speed running, output for 2 seconds.
82	Drop Speed	Action between the period from “stop idle” to “failed to stop”.
83	Pre-Lubricate	Actions in period of pre-heat to safety on.
84	Reserved	
85	Flashlight Output	Action when generator crank disconnect in auto mode. Press  button, control output.
86	Audible Alarm	Action when there are 10s left from start time in auto start mode.
87	Remote Control	Control genset via utility software or remote communication.
88	SMS Power	Control the power supply of GSM modem.

 NOTE: The contents of output port 1~4 can be set only via PC software.

### 8.3 ENABLE DEFINITION OF PROGRAMMABLE INPUT PORT 1-4

No.	Type	Description
0	Users Configured (See the form below for more details)	Including following functions, Indication: indicate only, not warning or shutdown. Warning: warn only, not shutdown. Shutdown: alarm and shutdown immediately Trip and stop: alarm, generator unloads and shutdown after hi-speed cooling Never: input inactive. Always: input is active all the time. From crank: detecting as soon as start. From safety on: detecting after safety run delay.

### 8.4 ENABLE DEFINITION CONTENTS

No.	Type	Description
0	Not Used	This input port function is disabled.
1	Users Configured	Alarm types, name and active ranges can be set by users.
2	Alarm Mute	Alarm will be displayed on the panel when the input is active. Audible alarm is muted and buzzer is turned off.
3	Inhibit Alarm Stop	When input is active, it is inhibit all alarms to stop the unit except for over speed alarm.
4	Remote Start	When input is active, it is can start genset remotely in auto remote start mode.
5	Lamp Test	When input is active, all indicators and LCD are illuminated.
6	Panel Lock	When input is active, buttons in the panel are deactivated.
7	Reserved	
8	Reserved	
9	Reserved	
10	Reserved	
11	Reserved	
12	Reserved	
13	Reserved	
14	Reserved	
15	Reserved	

 NOTE: The contents of input port 1~4 can be set only via PC software.

## 8.5 SENSOR SELECTION

No.	Items	Contents	Remark
1	Temperature Sensor	0 Not used 1 Digital closed 2 Digital open 3 VDO 120 degrees C 4 Datcon high 5 Datcon low 6 SGX 120 degrees C 7 Cummins 8 SGH 120 degrees C 9 Curtis 10 SGD 120 degrees C 11 Pt100 12 User defined	The range of user-defined resistor type sensor is 0-999 Ohm; by default VDO 120 degrees C sensor curve is selected. User defined sensor curve can be set via PC software.
2	Oil pressure Sensor	0 Not used 1 Digital closed 2 Digital open 3 VDO 5 bar 4 VDO 10 bar 5 Datcon 5 bar 6 Datcon 10 bar 7 Datcon 7 bar 8 SGX 10 bar 9 CMB812 10 SGH 10 bar 11 Curtis 12 SGD 10 bar 13 User defined	The range of user-defined resistor type sensor is 0-999 Ohm; by default VDO 10 bar sensor curve is selected. User defined sensor curve can be set via utility software.
3	Fuel Level Sensor	0 Not used 1 Digital closed 2 Digital open 3 VDO Ohm range (10-180) 4 VDO Tube type (90-0) 5 US Ohm range (240-33) 6 GM Ohm range (0-90) 7 GM Ohm range Ohm range (0-30) 8 Ford (73-10) 9 NKZR12/24-1-04 Ohm range (100-0) 10 User defined	The range of user-defined resistor type sensor is 0-999 Ohm; by default VDO Ohm range (10-180) sensor curve is selected. User defined sensor curve can be set via utility software.



## 8.6 SENSORS SETTING

1. When reselect sensors, the sensor curve will be transferred into the standard value. For example, if temperature sensor is SGX (120°C resistor type), its sensor curve is SGX (120°C resistor type); if select the SGD (120°C resistor type), the temperature sensor curve is SGD curve.
2. When there is difference between standard sensor curves and using sensor, user can adjust it in “curve type”.
3. When input the sensor curve, X value (resistor) must be input from small to large, otherwise, mistake occurs.
4. If select sensor type as “None”, sensor curve is not working.
5. If corresponding sensor has alarm switch only, user must set this sensor as “None”, otherwise, maybe there is shutdown or warning.
6. The headmost or backmost values in the vertical coordinates can be set as same as below,

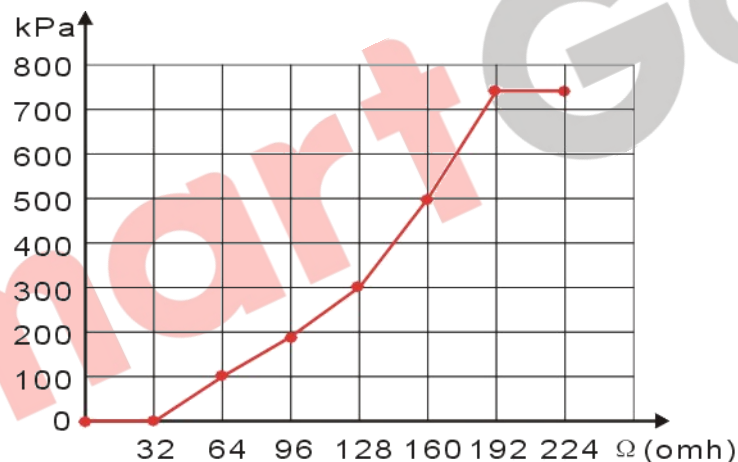

**Normal Pressure Unit Conversion Form**

	pa	kgf/cm <sup>2</sup>	bar	psi
1Pa	1	1.02x10 <sup>-5</sup>	1x10 <sup>-5</sup>	1.45x10 <sup>-4</sup>
1kgf/cm <sup>2</sup>	9.8x10 <sup>4</sup>	1	0.98	14.2
1bar	1x10 <sup>5</sup>	1.02	1	14.5
1psi	6.89x10 <sup>3</sup>	7.03x10 <sup>-2</sup>	6.89x10 <sup>-2</sup>	1

## 8.7 OVER CURRENT ACTION

The formula of over current delay value:

$$T = t / ((IA/IT)-1)^2$$

T: Overcurrent delay (second)

t: Timing multiplier ratio

IA: Current max. load current (L1/L2/L3)

IT: Overcurrent setting value

Example:

$$t = 36$$

$$IA = 600A$$

$$IT = 500A$$

Conclusion: T = 900s(15 minutes)

## 8.8 CONDITIONS OF CRANK DISCONNECT SELECTION

No.	Contents
0	Gen frequency (It is DC voltage when fitted with DC generator)
1	Speed sensor
2	Speed sensor + Gen frequency
3	Oil pressure
4	Oil pressure + Gen frequency
5	Oil pressure + Speed sensor
6	Oil pressure + Speed sensor + Gen frequency

## 8.9 LIGHT INPUTS SETTINGS

Work mode can be set as: Feedback input, Control input, Invalid. The control logic is as following:

System Mode	Light Inputs Setting	TFT Light Status	Light Relay Output Status	Panel Light Switch
Manuel Mode	Feedback Input	Light Status Input	Light Status Input	Valid
	Control Input	Light Status Input	Light Status Input	Invalid
	Invalid	Relay Status Output	Panel Switch	Valid
Auto Mode	Feedback Input	Light Status Input	System Control	Invalid
	Control Input	Relay Status Output	System Control	Invalid
	Invalid	Relay Status Output	System Control	Invalid
Stop Mode	Feedback Input	Light Status Input	Invalid	Invalid
	Control Input	Invalid	Invalid	Invalid
	Invalid	Invalid	Invalid	Invalid

## 8.10 BATTERY LOW VOLT WORK MODE

This feature is designed to protect the low battery voltage and ensure that the battery has enough power to start the unit. When the battery voltage has fallen below the set value, the unit cranks for a while and charge the battery; after running for a while, the unit will stop automatically. The work mode can be set as Invalid, Auto Mode Active, Manual Mode Active, Auto And Manual Mode Active.

## 8.11 TIMER MODE SELECT

Timer start mode can be set as daily, weekly, monthly and custom week. Users can set the start time, run duration, scheduled start or scheduled not start function. If the run duration is set as 00:00, then the unit will not be start.

## 8.12 SMS (ORDER AND REPLY)

No.	SMS Code	Description
1	SMS STOP	Stop mode order; set controller into stop mode; Stop running light tower set; Reply: SMS STOP OK
2	SMS START	Start order; can control light tower set to start; Reply: SMS START OK
3	SMS SUNRISE/SET START	Sunrise/sunset mode order Reply: SMS SUNRISE/SET START OK
4	SMS TIME SET 13-01-04 20:13:14	Set the time of controller; Set form: YY-MM-DD HH:MM:SS Reply: TIME SET OK YY-MM-DD HH:MM:SS
5	SMS GENSET	Inquiry order; inquiry the current status of controller. Reply: GENSET AT REST or GENSET IS RUNNING YY-MM-DD HH:MM:SS
6	SMS ENGINE	Inquiry all sensors' information Reply: all sensors' information and the real time
7	SMS OPS	Inquiry oil pressure sensor's information Reply: oil pressure
8	SMS WTP	Inquiry temperature sensor's information Reply: engine temperature
9	SMS FLE	Inquiry fuel level sensor's information Reply: fuel level sensor's information

▲ NOTE: Its national and area's cods must be added, e.g. Chinese number should be set as +8613666666666 or **008613666666666**.

▲ NOTE: The SMS orders are active only when GSM modem is enabled. In addition, the 1~3 SMS orders are active only in AUTO DIAL-UP MODE.







▲ NOTE: The controller will send alarm information to preset telephone automatically when shutdown alarm or trip alarm occur.



## 8.13 SUNRISE/SET SET

Users can select corresponding city or define city's information (longitude, latitude and time zone) via utility software and download the information into controller; then controller will run in auto sunrise/set mode.



▲ NOTE: The information can be configured by software via PC only.

## 9 PARAMETERS SETTING



- 1) **Parameters Setting:** After controller power on, press , then select **1 Set Parameters**, then press  again to advanced parameter password confirmation interface. Press  and  to increase or decrease values and input the corresponding password 0~9; press  key to right move the bit, in fourth bit press  key to check password. If password is correct, enter into advanced parameter setting interface, otherwise, exit directly. (Factory default password is **1234** and users can modify it.)

Press “+” key and “-” key to scroll screen; select parameter you want to configure and press  key (the parameter will highlight with black), press “+” key or “-” key to change parameter value, press  key to move the bit, in fourth bit press  key to confirm setting and the set value will be saved into internal FLASH (picture on the right).

Parameter Setting	
01 Timer Start	
Start Time	Duration
18:50	08:30

- 2) **Date and Time Setting:** After controller power on, press , then select **3 Time Calibration**, press  again to the Date and Time Setting interface. The first line is current date and time and the second line is the time information of user’s modification. The digital which highlight with black is currently adaptable for user by pressing “+” key and “-” key to increase and decrease the value. Press  key to confirm setting and the bit will right move automatically. Number “5” in the parenthesis is the week information. It is set by the microprocessor based on current date, so the user does not need to modify it. (picture on the right)

Date and Time	
Current Time:	
13-01-04 (5) 08:27:55	
13-01-04 (5) 08:27:23	

 **NOTE:** Pressing  button during parameter setting will immediately exit the set parameter interface and set the controller into standby mode.

## 10 EVENT LOG

Maximum 99 pieces of event logs can be circularly stored into controller. Shutdown alarms and real time information will be record but warning alarms. If the alarm records are more than 99 pieces, then the latest record will replace the oldest one.

Press , then select **2 Event Log**, press  again to inquiry the event log (See picture below). Press  and  to read records and  to exit directly;

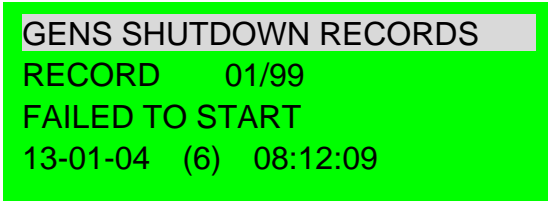

GENS SHUTDOWN RECORDS  
RECORD 01/99  
FAILED TO START  
13-01-04 (6) 08:12:09

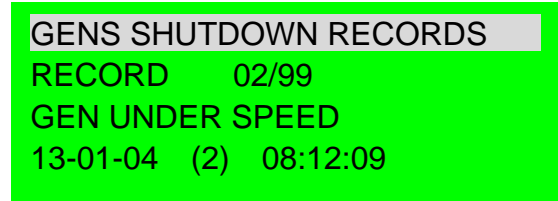

GENS SHUTDOWN RECORDS  
RECORD 02/99  
GEN UNDER SPEED  
13-01-04 (2) 08:12:09

SmartGen

## 11 COMMISSIONING

Please make the under procedures checking before commissioning,

1. Ensure all the connections are correct and wires diameter is suitable.
2. Ensure that the controller DC power has fuse, controller's positive and negative connected to start battery are correct.
3. Emergence stop must be connected with positive of start battery via scram button's normal close point and fuse.
4. Take proper action to prevent engine to crank disconnect (e. g. Remove the connection wire of fuel valve). If checking is OK, make the start battery power on; choose manual mode and controller will executive routine.
5. Set controller under manual mode, press "start" button, genset will start. After the cranking times as setting, controller will send signal of Start Fail; then press "stop" to reset controller.
6. Recover the action of prevent engine start (e. g. Connect wire of fuel valve), press start button again, genset will start. If everything goes well, genset will normal run after idle running (if idle run be set). During this time, please watch for engine's running situations and AC generator's voltage and frequency. If abnormal, stop genset running and check all wires connection according to this manual.

## 12 TYPICAL WIRING DIAGRAMS

ALC708 Typical Wiring Diagram

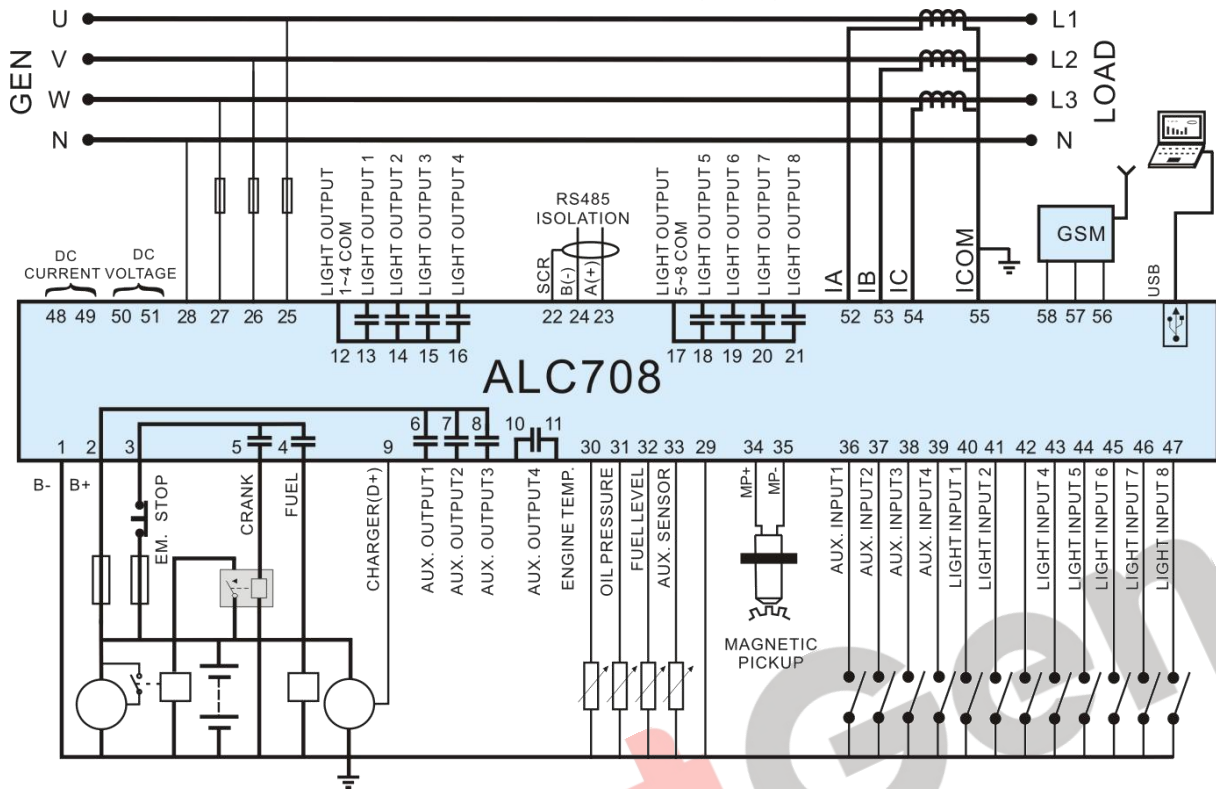

**Note:** If 8 lights are all used, the maximum current of each light is 2A.

ALC704 Typical Wiring Diagram

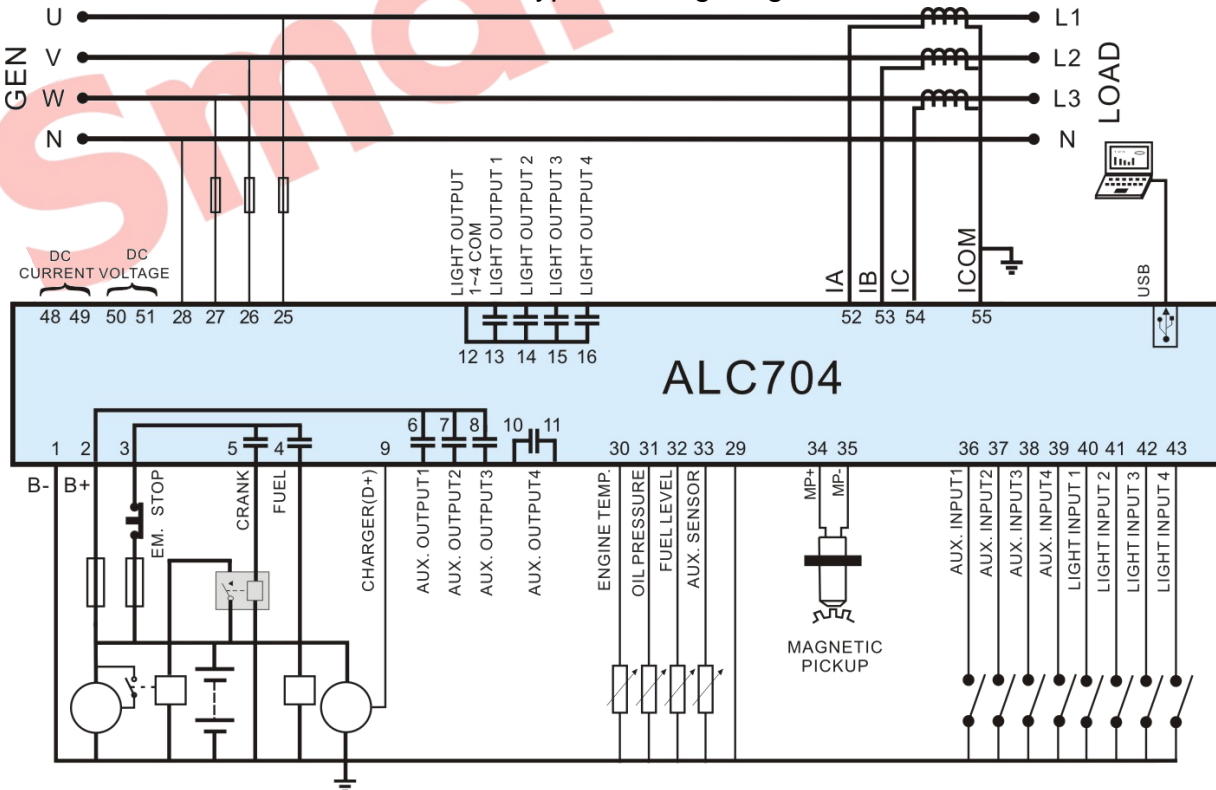

**Note:** If 4 lights are all used, the maximum current of each light is 2A.



## DC Generator Typical Wiring Diagram

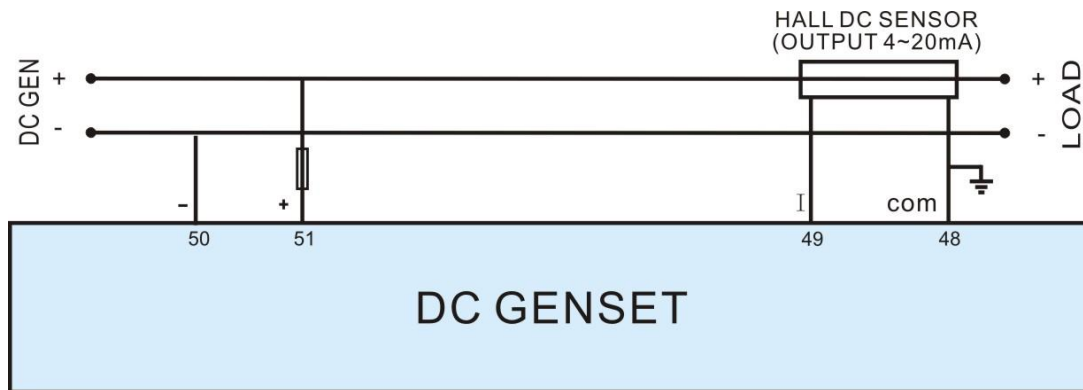

**NOTE:** Users should select suitable Hall DC sensor according to the output power and current of the light tower set.

## 13 INSTALLATION

Controller is panel built-in design; it is fixed by clips when installed. The controller's overall dimensions and cutout dimensions for panel, please refers to as following,

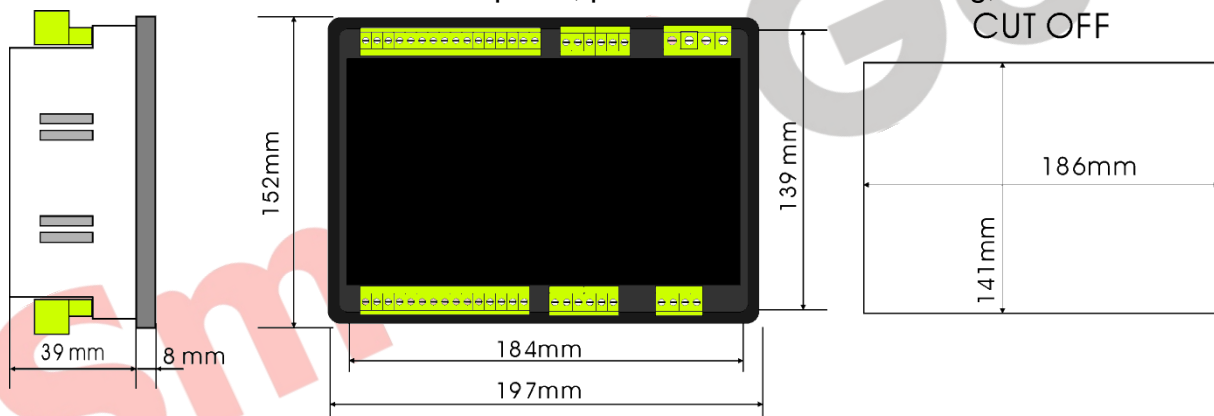

### 13.1 BATTERY VOLTAGE INPUT

ALC700 controller can suit for widely range of battery voltage DC (8~35)V. Negative of battery must be connected with the engine shell. The diameter of wire which from power supply to battery must be over  $2.5\text{mm}^2$ . If floating charger is fitted, please firstly connect output wires of charger to battery's positive and negative directly, then, connect wires from battery's positive and negative to controller's positive and negative input ports in order to prevent charge disturbing the controller's normal working.

### 13.2 SPEED SENSOR INPUT

Speed sensor is the magnetic equipment which be installed in starter and for detecting flywheel teeth. Its connection wires to controller should apply for 2 cores shielding line. The shielding layer should connect to No. 35 terminal in controller. The else two signal wires are

connected to No.34 and No.35 terminals in controller. The output voltage of speed sensor should be within AC(1~24)V (effective value) during the full speed. AC12V is recommended (in rated speed). When install the speed sensor, let the sensor is spun to contacting flywheel first, then, port out 1/3 lap, and lock the nuts of sensor at last.

### 13.3 OUTPUT AND EXPAND RELAYS

All outputs of controller are relay contact output type. If need to expand the relays, please add freewheel diode to both ends of expand relay's coils (when coils of relay has DC current) or, add resistance-capacitance return circuit (when coils of relay has AC current), in order to prevent disturbance to controller or others equipment.

### 13.4 AC INPUT

Current input of ALC700 controller must be connected to outside current transformer. And the current transformer's secondary side current must be 5A. At the same time, the phases of current transformer and input voltage must correct. Otherwise, the current of collecting and active power maybe not correct.

 **NOTE:** ICOM port must be connected to negative pole of battery.

 **WARNING!** When there is load current, transformer's secondary side prohibit open circuit.

### 13.5 DC CURRENT INPUT

Hall DC sensor must be connected externally to the ALC700 controller and the output value is 4-20mA.

### 13.6 WITHSTAND VOLTAGE TEST

When controller had been installed in control panel, if need the high voltage test, please disconnect controller's all terminal connections, in order to prevent high voltage into controller and damage it.

## 14 FAULT FINDING

Here are the common faults and troubleshooting. If there is any other problem, please feel free to contact SmartGen's service.

Symptoms	Possible Solutions
Controller no response with power.	Check starting batteries; Check controller connection wirings; Check DC fuse.
Light tower set shutdown	Check the water/cylinder temperature is too high or not; Check the generator AC voltage; Check DC fuse.
Controller emergency stop	Check emergence stop button is correct or not; Check whether the starting battery positive be connected with the emergency stop input; Check whether the circuit is open.
Low oil pressure alarm after crank disconnect	Check the oil pressure sensor and its connections.
High water temp. alarm after crank disconnect	Check the temperature sensor and its connections.
Shutdown Alarm in running	Check related switch and its connections according to the information on LCD; Check programmable inputs.
Start Failure	Check fuel circuit and its connections; Check starting batteries; Check speed sensor and its connections; Refer to engine manual.
Starter no response	Check starter connections; Check starting batteries.

## 15 WHOLE SET OF PRODUCT

The product includes the following parts:

ALC700 controller: 1

Fixed clip: 4

Certificate: 1

User manual: 1