



**SmartGen**  
ideas for power

# HWP30N/HWP40N FORCED CIRCULATION HEATER USER MANUAL



**SMARTGEN (ZHENGZHOU) TECHNOLOGY CO., LTD.**



Chinese trademark

**SmartGen** English trademark

SmartGen – make your generator *smart*

SmartGen Technology Co., Ltd.

No.28 Jinsuo Road, Zhengzhou, Henan Province, China

Tel: +86-371-67988888/67981888/67992951

+86-371-67981000(overseas)

Fax: +86-371-67992952

Email: [sales@smartgen.cn](mailto:sales@smartgen.cn)

Web: [www.smartgen.com.cn](http://www.smartgen.com.cn)

[www.smartgen.cn](http://www.smartgen.cn)

All rights reserved. No part of this publication may be reproduced in any material form (including photocopying or storing in any medium by electronic means or other) without the written permission of the copyright holder.

Applications for the copyright holder's written permission to reproduce any part of this publication should be addressed to SmartGen Technology at the address above.

Any reference to trademarked product names used within this publication is owned by their respective companies.

SmartGen Technology reserves the right to change the contents of this document without prior notice.

**Table 1 - Software Version**

Date	Version	Note
2019-09-07	1.0	Original release.
2020-08-07	1.1	Modify the product appearance figure.
2020-12-11	1.2	1. Add the power on manual and auto modes, save the work mode before power off; add the indicator introductions of temperature, voltage, running time and power consumption; optimize the words and punctuations; 2. Modify the product weight.
2021-01-26	1.3	1. Add the model HWP30N; 2. Modify the figure of pagoda header.
2021-04-26	1.4	1.Changed the water drain valve; 2.Changed the water drain valve drawing.



## CONTENT

1. OVERVIEW.....	4
2. PERFORMANCE AND CHARACTERISTICS.....	4
3. SPECIFICATION .....	5
4. HEATER INSTALLATION .....	6
5. OPERATING INSTRUCTIONS .....	7
5.1 BUTTON DESCRIPTION.....	7
5.2 INDICATOR DESCRIPTION .....	7
5.3 DISPLAY ILLUSTRATION.....	8
5.4 FAULT CODE .....	8
5.5 OPERATION PANEL.....	9
5.6 OPERATION DESCRIPTION .....	9
6. USE AND MAINTENANCE .....	10
7. CASE AND DIMENSIONS.....	11
8. PACK LIST .....	11

SmartGen

## 1. OVERVIEW

HWP30N/HWP40N is smart forced circulation water heater of engine. When engine operation temperature is below 4°C, engine liquid coolant/lubricating oil may be coagulated to solid state in starting phase and lose lubrication or cooling effects, so that it may damage the engine. Therefore, heater shall be installed for engine to ensure normal starting and running.

It has lamp indication function, which can indicate all kinds of heater statuses. Heating temperature can be set by users, and dry burning prevention and overheating protection are fitted.

This product is suitable for various engines with (15~30)L displacement.

## 2. PERFORMANCE AND CHARACTERISTICS

- Micro-processor design is applied for the control part, precise temperature sampling, heating temperature can be set from control panel.
- 4-bit digital tube display is applied, which can display current coolant temperature, user defined temperature, accumulated running time, accumulated energy consumption, current voltage parameters etc.
- Water flow sensor is fitted, which can quickly detect shortage of water, pipe gas gathering, pipe clog, in order to prevent heater from dry burning, gas gathering etc. unhealthy phenomenon.
- Circulation pump and heater are controlled separately; water pump is firstly started before heating, and then heater starts after delay for 5s; when it reaches pre-set temperature point, heater power is disconnected immediately; then water pump power is cut off after delay for 60s; this is to prevent heat gathering so that it can prolong pump life.
- Manual test function is fitted, which can check whether heating body and water pump is able to operate normally through panel button.
- Fine cast aluminum material is used for heater shell.
- Stainless steel inner heating pipes.
- Water drain valve is fitted at the bottom of the heating body, which can be used on demand.
- This product can work normally at -40°C temperature.

### 3. SPECIFICATION

**Table 2 – Parameter Specification**

Type	HWP30N	HWP40N
Rated Power	3000W	4000W
Rated Voltage	AC 240V	
Rated Current	12.5A	16.7A
Phase	Single phase	
Engine Displacement	13~20L	20~30L
Thermostat Range	Off: (5~70)°C	On: (0~65)°C
Default Thermostat Range	Off: (40±2)°C	On: (25±2)°C
Overheating Thermostat Range	Off: (95±3)°C	On: Manual
Insulating Resistance	≥50MΩ	
Electrical Strength	AC 1.5kV 1min	
Inlet/Outlet Size	G 3/4 Internal thread (Selectable Φ19.5mm Pagoda header or G 3/4 External thread)	
Max. Water Pressure	0.5MPa	
Pump Flow Velocity	40L/min (1.5m of lift)	
Protection Level	IP44	
Vibration Resistance	(5~8)Hz Amplitude±7.5mm Triaxial (8~500)Hz a=2g Triaxial	
Shock Resistance	Half-sine Wave; a <sub>peak</sub> =50g; Triaxial	
Working Conditions	-40 °C~+70 °C	
Storage Conditions	-40 °C~+80 °C	
Case Dimensions	414 mm×261 mm×190 mm	
Weight (include accessories)	5.3kg	

#### 4. HEATER INSTALLATION

Please install the heater vertically according to the diagram before use. Pay attention to the direction of heater inlet and outlet, and ensure that the heater position is below the lowest water level of the engine and that all the air is exhausted out of the heater. Perfuse the heater with coolant.

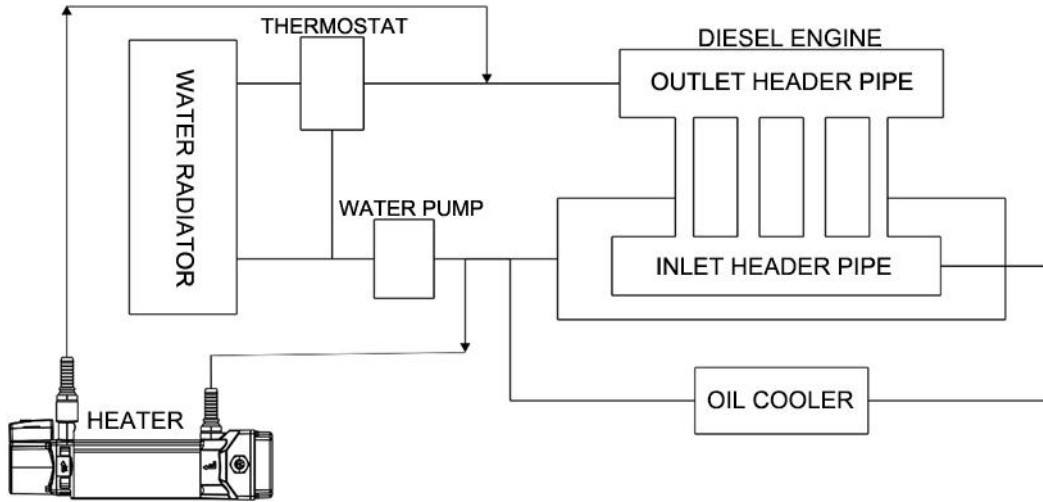

**Fig. 1 - Installation Logic Diagram**

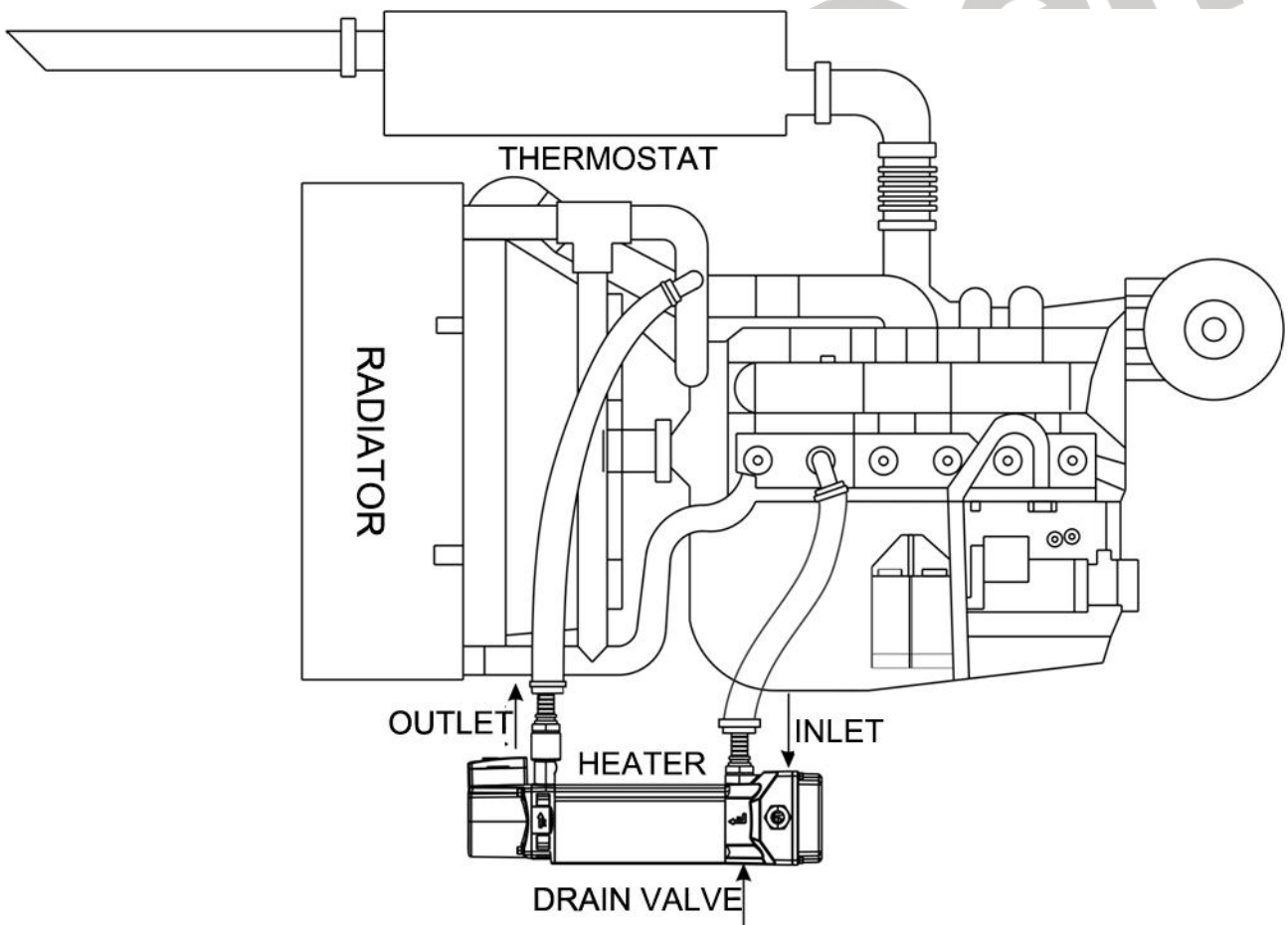





**Fig. 2 - Installation Side Schematic**

## 5. OPERATING INSTRUCTIONS

### 5.1 BUTTON DESCRIPTION

**Table 3 – Panel Display and Buttons**

Button	Definition	Description
	Heating	Press and if coolant temperature is below the set cut-off temperature, heater will transfer to auto status; if coolant temperature is above the set cut-off temperature, heater works for 15s and enters auto status after commissioning.
	Stop	Press and heater will stop.
	Set	Press and enter parameter setting menu.
	Up	Display the last digital cube content and do value adjustment.
	Down	Display the next digital cube content and do value adjustment.









### 5.2 INDICATOR DESCRIPTION

**Table 4 - Indicator Description**

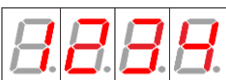
Sign	Definition	Description
Alarm	Alarm indicator	When lamp is illuminated, heater fault occurs and please decide fault type according to the fault code of digital cube.
Auto/Heat	Auto/Heating	Heater is in auto state when it is flashing; it is in heating state when the lamp is always illuminated.
Stop	Stop indicator	Heater is in stop state when lamp is illuminated.
°C	Temp. indicator	They are used to indicate the type of value displayed on main interface; after entering the password on display interface, press the up button or down button, the running time indicator or power consumption indicator is illuminated; when on the parameter value interface, the calibration serial number interface, the software version interface and the enter password interface, the four indicators flash 0.5s once.
V	Volt. Indicator	
10xHour	Running time indicator	
10xkWh	Power consumption indicator	

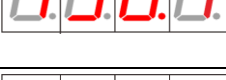

### 5.3 DISPLAY ILLUSTRATION

**Table 5 - Display Illustration**

Sign	Definition	Description
	Cut-off Temperature	The set value of target temperature
	Reset Temperature	The set value of reset temperature
	Current Voltage Value	It is current power voltage when V indicator is light on.
	Accumulated Running Time	It is total running time when 10×Hour indicator is light on; unit is hour, detailed hours are the displayed number x10; e.g. displayed number is 1234, and the actual hours are 12340.
	Accumulated Energy Consumption	It is total energy consumption when 10×kWh indicator is light on; unit is kWh; detailed kWh is the displayed number x10; e.g. displayed number is 456.7, and the actual kWh is 4567.
	Water Flow Sensor Enable	00: Disable; 01: Enable.
	Dry Burning Temperature Sensor Enable	00: Disable; 01: Enable.
	Voltage Protection Enable	00: Disable; 01: Enable.
	Start Mode	00: Power on manual start mode 01: Power on auto start mode 02: Keep the work mode before power off.

### 5.4 FAULT CODE

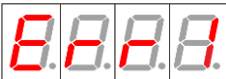
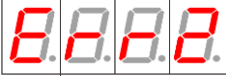
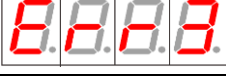
**Table 6 - Fault Code**

Sign	Definition	Description
	Fault Code 1	Dry burning/water shortage protection.
	Fault Code 2	Water temperature sensor open circuit.
	Fault Code 3	Dry burning temperature sensor open circuit.
	Over Voltage	Enters standby status when input voltage is over 264V.
	Under Voltage	Enters standby status when input voltage is over 200V.



## 5.5 OPERATION PANEL

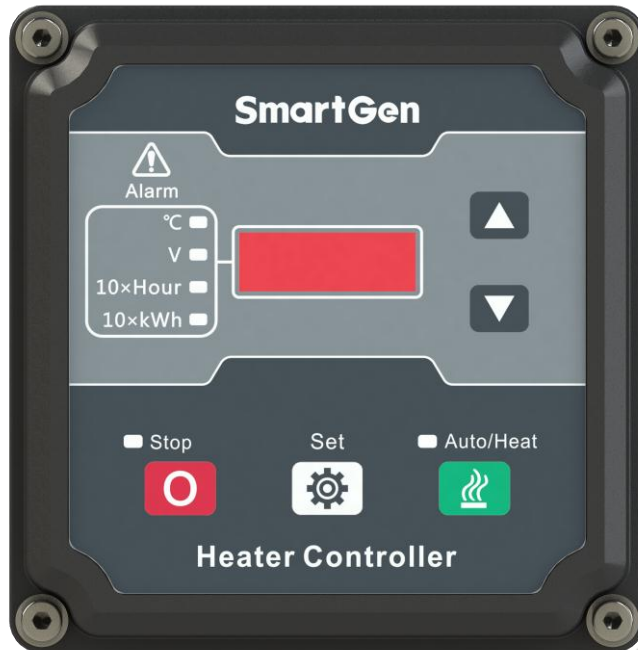



Fig. 3 – Operation Panel Drawing

## 5.6 OPERATION DESCRIPTION







### 5.6.1 Parameter Check

Press  and  to switchover digital cube display and do value adjustment.

### 5.6.2 Commissioning

If water temperature is above pre-set reset temperature, press  and heater will enter commissioning status, and it will transfer to auto status after heating for 10s.

### 5.6.3 Parameter Setting

Press  and enter parameter setting menu, and it will display  (H means the set temperature is cut-off temperature value, 40°C is only an example). Press  again to enter the setting, and adjust values by  and . Press  again to move or confirm.

Press  and it will go back to the main menu. It will also return back to first page if there is no operation within 1 minute.

## 6. USE AND MAINTENANCE

Unit: mm

- 1) After it is connected with power, heater is at stop state. Press Auto/Heat and make heater enter working status.
- 2) When it needs to be checked/fixed or change pipe or some part, press Stop and make heater enter stop status.
- 3) Before start please confirm whether heater is fully filled with coolant and make gas in the pipe exhausted by vent valve.
- 4) It is strongly suggested to use antifreezing solution with corresponding mark number.
- 5) If ordinary water is used, users must drain the water after stop when environment temperature is below 0°C, in order to prevent the water in the heater getting frozen and resulting in heater fracture.
- 6) GND wire must be earth connected.
- 7) Drain valve: Can be opened or closed using hexagonal wrench, adjustable wrench, or a cross screwdriver.



Fig. 4 – Vent Valve Indicating Diagram

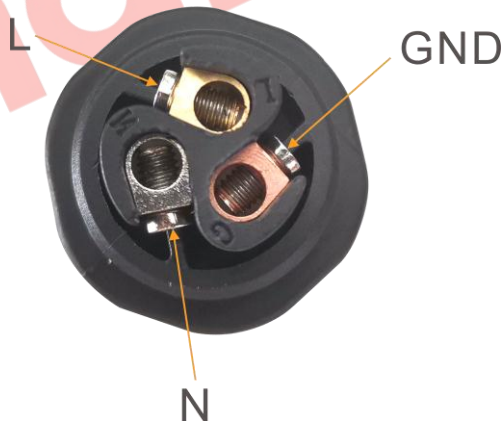

Fig. 5 Wire Connection

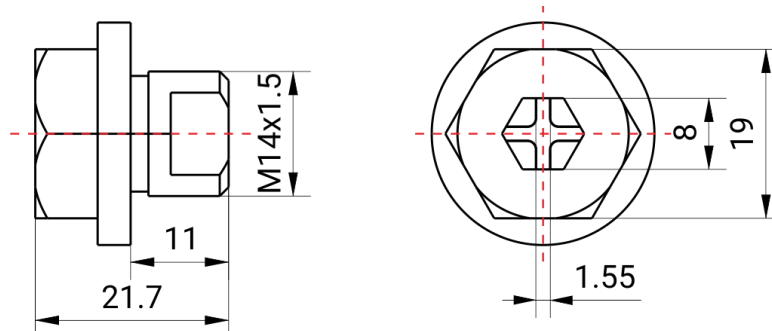
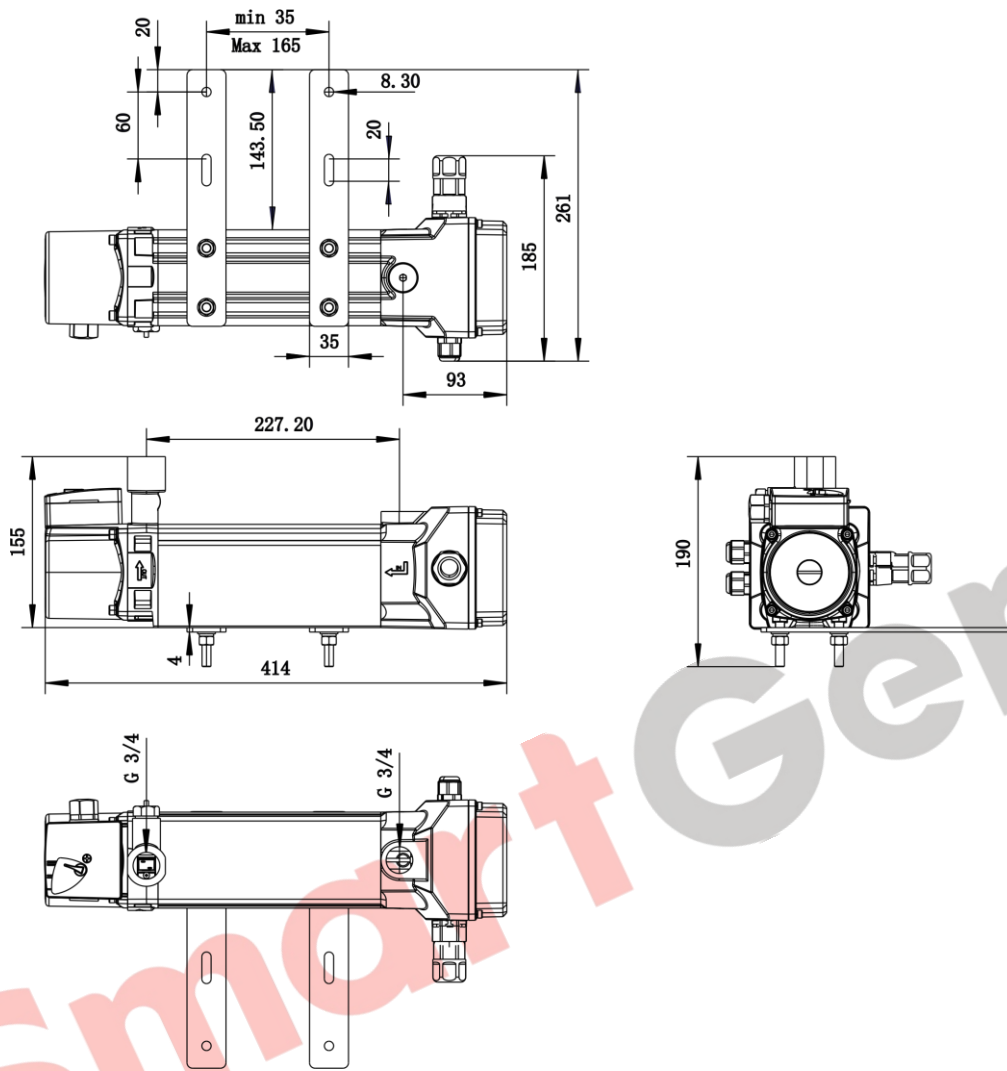

Fig. 6 Vent Valve Size

## 7. CASE AND DIMENSIONS

Unit: mm



**Fig. 7 – Overall Dimensions**

**NOTE:** all the inlets/outlet connectors are internal thread G 3/4.

## 8. PACK LIST

**Table 7 - Pack List**

No.	Name/Model	Number for one unit
1	Product	1
2	Stand	2
3	Flat Gasket GB/T 95 8	8
4	Spring Washer GB/T 93 8	8
5	Hexagon Nut GB/T 41 M8	8
6	Hexagon Slot GB/T 5783 M8×40	8
7	User Manual	1



**Table 8 - Water Gate Accessories**

Unit: mm

No.	Name/Model	Number for one unit
1	Φ19.5mm Pagoda Joint	2
2	G 3/4 Stainless steel pair screw	2
3	ED Sealing gasket	2

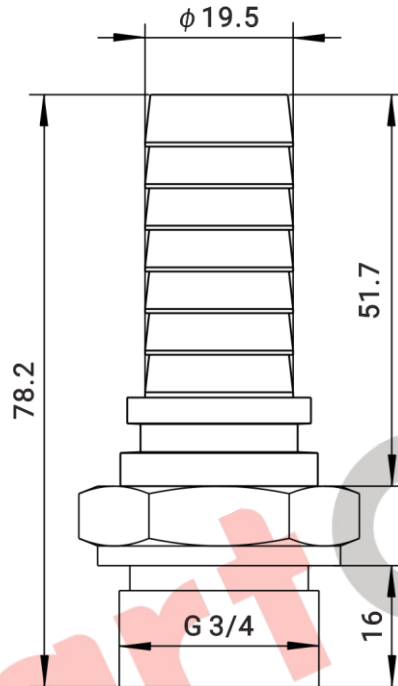

**Fig. 8 Pagoda Header Size**

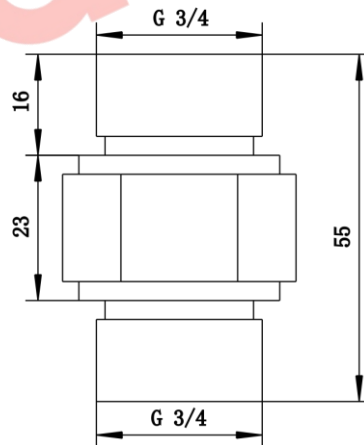

**Fig. 9 Pair Screw Size**