



SmartGen
ideas for power

HGM8110DC-1

GENSET CONTROLLER

USER MANUAL



SMARTGEN (ZHENGZHOU) TECHNOLOGY CO., LTD.



Chinese trademark

SmartGen English trademark

SmartGen – make your generator *smart*

SmartGen Technology Co., Ltd.

No.28 Jinsuo Road

Zhengzhou

Henan Province

P. R. China

Tel: +86-371-67988888/67981888/67992951

+86-371-67981000(overseas)

Fax: +86-371-67992952

Web: www.smartgen.com.cn/

www.smartgen.cn/

Email: sales@smartgen.cn

All rights reserved. No part of this publication may be reproduced in any material form (including photocopying or storing in any medium by electronic means or other) without the written permission of the copyright holder.

Applications for the copyright holder's written permission to reproduce any part of this publication should be addressed to SmartGen Technology at the address above.

Any reference to trademarked product names used within this publication is owned by their respective companies.



SmartGen Technology reserves the right to change the contents of this document without prior notice.

Table 1 - Software Version

Date	Version	Note
2021-12-25	1.0	Original release.

This manual is suitable for HGM8110DC-1 controller only.

Table 2 - Notation Clarification

Symbol	Instruction
 NOTE	Highlights an essential element of a procedure to ensure correctness.
 CAUTION	Indicates a procedure or practice, which, if not strictly observed, could result in damage or destruction of equipment.
 WARNING	Indicates a procedure or practice, which could result in injury to personnel or loss of life if not followed correctly.

SmartGen

CONTENTS

1 OVERVIEW	6
2 MODELS COMPARISON	7
3 PERFORMANCE AND CHARACTERISTICS	8
4 SPECIFICATION	10
5 OPERATION	12
5.1 KEY FUNCTION	12
5.2 CONTROLLER PANEL	13
5.3 LCD DISPLAY	14
5.3.1 MAIN DISPLAY	14
5.3.2 PARAMMETERS SETTING MENU	15
5.3.3 PARAMETER SETTINGS	15
5.4 AUTO START/STOP OPERATION	16
5.5 MANUAL START/STOP OPERATION	17
5.6 GENSET CONTROLLER SWITCH CONTROL PROCEDURES	18
5.6.1 MANUAL CONTROL PROCEDURES	18
5.6.2 AUTO CONTROL PROCEDURES	18
6 PROTECTION	19
6.1 WARNING ALARMS	19
6.2 SHUTDOWN ALARM	22
6.3 TRIP AND STOP ALARM	25
6.4 TRIP ALARM	26
7 WIRINGS CONNECTION	27
8 SCOPES AND DEFINITIONS OF PROGRAMMABLE PARAMETERS	30
8.1 CONTENTS AND SCOPES OF PARAMETERS	30
8.2 ENABLE DEFINITION CONTENTS OF DIGITAL OUTPUT PORTS	43
8.2.1 DEFINED CONTENTS OF DIGITAL OUTPUT PORTS	43
8.2.2 CUSTOM PERIOD OUTPUT	48
8.2.3 CUSTOM COMBINED OUTPUT	48
8.3 DEFINED CONTENTS OF DIGITAL INPUT PORTS (ALL GND(B-) CONNECTED ACTIVE)	49
8.4 SELECTION OF SENSORS	51
8.5 SELECTION OF CRANK DISCONNECT CONDITIONS	52
9 PARAMETERS SETTING	53
10 SENSORS SETTING	54
11 COMMISSIONING	55
12 TYPICAL APPLICATION	56
13 INSTALLATION	57
13.1 OVERALL DIMENSION	57
13.2 BATTERY VOLTAGE INPUT	57
13.3 SPEED SENSOR INPUT	57
13.4 OUTPUT AND EXPAND RELAYS	57



13.5 AC INPUT	57
13.6 WITHSTAND VOLTAGE TEST	58
14 CONNECTIONS OF CONTROLLER WITH J1939 ENGINE	59
14.1 CUMMINS ISB/ISBE	59
14.2 CUMMINS QSL9	59
14.3 CUMMINS QSM11 (IMPORT)	60
14.4 CUMMINS QSX15-CM570	60
14.5 CUMMINS GCS-MOVBUS	61
14.6 CUMMINS QSM11	61
14.7 CUMMINS QSZ13	62
14.8 DETROIT DIESEL DDEC III / IV	62
14.9 DEUTZ EMR2	63
14.10 JOHN DEERE	63
14.11 MTU MDEC	63
14.12 MTU ADEC (SMART MODULE)	64
14.13 MTU ADEC (SAM MODULE)	64
14.14 PERKINS	65
14.15 SCANIA	65
14.16 VOLVO EDC3	65
14.17 VOLVO EDC4	66
14.18 VOLVO-EMS2	66
14.19 YUCHAI	67
14.20 WEICHAI	67
15 ETHERNET INTERFACE	68
15.1 ILLUSTRATION	68
15.2 NETWORK CLIENT CONNECTION	68
15.3 DESCRIPTION OF CONTROLLER CONNECTION CABLE	68
16 TROUBLESHOOTING	69

1 OVERVIEW

HGM8110DC-1 Genset Controller is especially designed for single unit system in DC and AC applications, which can be adapt to extremely high/low temperature environments (-40°C~+70°C). Controller applies LCD with low temperature heating function and electronic components which bear extreme high and low temperatures, so that it can work reliably under extreme temperatures. After careful consideration about electromagnetic compatibility under various occasions at designing, this provides powerful guarantee for the controller to work reliably under complex environment of strong electromagnetic interference. Controller is pluggable terminal structure, which is very convenient for product maintenance, upgrade and update. Controller can display Chinese and English languages.

HGM8110DC-1 Genset Controller integrates digitization, intelligence and network technology which is used for genset automation and monitoring system of single unit to achieve automatic start/stop, DC and AC data measurement, alarm protection and “three remote” functions. Controller adopts 32-bit micro-processor technology, realizing precise measurement of various parameters, fixed value adjusting, timing, threshold setting etc. A majority of parameters can be configured from front panel, and all parameters can be configured by PC via USB port, or RS485 or RS232 or ETHERNET to adjust and monitor. It can be widely used in all types of automatic genset control system with compact structure, simple wiring, and high reliability.

2 MODELS COMPARISON

HGM8100DC series controllers include HGM8110DC, HGM8110DC-1 and HGM8110DC-2. HGM8110DC-1 is the fully local version of HGM8110DC, HGM8110DC-2 is the upgraded version of HGM8110DC. Model comparison of HGM8110DC, HGM8110DC-1 and HGM8110DC-2 is as Table 3.

Table 3 - Models Comparison

Models	HGM8110DC	HGM8110DC-1	HGM8110DC-2
Display	VFD	LCD	VFD
DC Monitoring	•		•
Mains Monitoring	None		None
Input Number	8		8
Output Number	8		8
Sensor Number	5		5
Earth Current	•		•
Schedule Function	•		•
RS485	•		•
ETHERNET	•		•
RS232	•		•
J1939	•		•
CANBUS Port Number	2		3
USB	•		•
Real-time Clock	•		•
Event Log	•		•
Expand Input/Output	•		•

NOTE:

- 1) Two fixed output ports in the output ports: starting output and fuel output.
- 2) Analog sensors consist of three fixed sensors (temperature sensor, pressure sensor and fuel level sensor) and two flexible sensors.

3 PERFORMANCE AND CHARACTERISTICS

HGM8110DC-1: It is DC genset controller and used for AC and (or) DC single automation systems to control genset start/stop through remote signal; It is especially suitable for single unit automation system made up of 1-way DC and 1-way AC.

Main characteristics are as below,

- 32-bit ARM SCM, highly integrated hardware, reliability gets improved;
- Large graphic dot matrix self-heating LCD display, selectable Chinese/English interface which can be chosen at the site, making commissioning convenience for factory personnel;
- LCD adopts hard screen acrylic material with good wear-resisting and scratch-resisting;
- Silicone panel and pushbuttons, strong adaptability of extreme temperature environments;
- RS485 and RS232 communication interfaces, which can realize “Three remote functions” (remote control, remote measuring and remote communication) by using MODBUS protocol;
- ETHERNET communication port, which can realize ETHERNET monitoring method (controller with ETHERNET port is needed);
- Equipped with CANBUS port, which can connect ECU engine with J1939, which not only can monitor frequently-used data (such as water temperature, oil pressure, speed, fuel consumption and so on) of ECU machine, but also control starting up, shutdown, raising speed and speed drop via CANBUS port (controller with CANBUS interface is needed);
- Suitable for 3-phase 4-wire, 3-phase 3-wire, single phase 2-wire, and 2-phase 3-wire systems with voltage 120/240V and system with frequency 50/60Hz;
- Collects and shows AC Gen 3-phase voltage, current, frequency, power parameters;
- Collects and shows DC Gen voltage, current, power parameters:

AC

Line voltage (Uab, Ubc, and Uca)
 Phase voltage (Ua, Ub, and Uc)
 Phase sequence
 Frequency Hz

DC

Voltage U
 Power
 Current I
 Accumulative electric power

Load

Current	Ia, Ib, Ic	A (unit)
Each phase and total active power	P	kW (unit)
Each phase and total reactive power	Q	kvar (unit)
Each phase and total apparent power	S	kVA (unit)
Each phase and average power factor	λ	1 (unit)
Accumulated total generator power	W	kWh, kvarh, kVAh (unit)
Earth current	I	A (unit)

- For AC Generator, controller has over and under voltage, over and under frequency, over current, over power, reverse power, loss of phase and reverse phase sequence detection functions; for DC Generator, controller has over and under voltage, over current, and over power detection functions;
- 3 fixed analog sensors (temperature, oil pressure and fuel level);
- 2 configurable analog sensors can be set to sensor of temperature, oil pressure or fuel level; resistor/voltage/current type sensors are supported;
- Precisely measure various parameters of engine:

Temp. (WT)	°C/°F can be selected
Oil pressure (OP)	kPa/psi/bar can be selected



Fuel level (FL)	% (unit)
Speed (SPD)	r/min (unit)
Voltage of Battery (VB)	V (unit)
Voltage of Charger (VD)	V (unit)
Timer	accumulative to max. 65535 hours.
Accumulated Start times	accumulative to max. 65535 times.

- Control and protection function: realize automatic start/stop of the diesel genset, breaker close and open (ATS transfer) control and perfect fault indication protection function;
- All output ports are relay outputs;
- Parameter setting function: parameters can be modified by users and stored in internal FLASH memory and cannot be lost even in case of power outage; most of them can be adjusted by using front panel of the controller and all of them can be modified by using PC via USB port, RS485, RS232 or ETHERNET ports;
- Multiple curves of temperature, oil pressure, and fuel level sensors can be used directly and users can define the sensor curves by themselves;
- Multiple crank disconnect conditions (speed, oil pressure, generator frequency) are optional;
- Wide power supply range DC(8~35)V, suitable for different starting battery voltage environment;
- Event log, real-time clock, scheduled start & stop generator functions (can be set to start genset once a day/week/month with load or not).
- PLC (Programmable Logic Control) function. Users can use graphical programming to achieve specific functions;
- Can be used as an indicating instrument (only for indication and alarm, no action for relay);
- Maintenance function. Actions (warning, trip and stop or shutdown) can be set when maintenance time is out;
- All parameters are digitally adjusted, getting rid of conventional analog modulation with normal potentiometer, improving whole case's reliability and stability;
- Ingress protection level IP65 due to rubber gasket installed between the controller enclosure and control panel;
- Metal fixing clips are used to fix controller, outstanding performance in high temperature environment;
- Modular design, pluggable connection terminals and embedded installation way; compact structure with easy mounting;
- Accumulative running A and B, accumulative electric power A and B; users can zero clear them and accumulate them again, making convenience for users.

4 SPECIFICATION

Table 4 - Technical Parameters

Item	Contents
Operating Voltage	DC8.0V to DC35.0V, Continuous Power Supply.
Power Consumption	<8W (standby ≤3W)
Alternator Input Range	
3Phase 4Wire	AC15V - AC 360V (ph-N)
3Phase 3Wire	AC30V - AC620V (ph-ph)
Single Phase 2Wire	AC15V - AC360V (ph-N)
2Phase 3Wire	AC15V - AC360V (ph-N)
Alternator Frequency	50/60Hz
DC Generator Voltage Input	DC 0V - 10V (Transmitter post voltage, ratio can be set)
Load DC Current Input	DC 4mA - 20Ma (Transmitter post current, ratio can be set)
Speed Sensor Voltage	1.0V to 24V (RMS)
Speed Sensor Frequency	Max. 10000Hz
Starter Relay Output	16A DC28V at supply output
Fuel Relay Output	16A DC28V at supply output
Programmable Relay Output (1)	7A DC28V at supply output
Programmable Relay Output (2)	7A DC28V at supply output
Programmable Relay Output (3)	7A DC28V at supply output
Programmable Relay Output (4)	7A AC250V voltage free output
Programmable Relay Output (5)	8A AC250V voltage free output
Programmable Relay Output (6)	8A AC250V voltage free output
RS485 Port	Isolated, half-duplex, 9600 baud rate, longest communication distance 1000m
Internet Access	10/100Mbit
Vibration Test	Frequency: 5Hz~8Hz; amplitude±7.5mm; Frequency: 8Hz~500Hz; fixed acceleration=2g; IEC 60068-2-6
Shock Test	a=50g; Pulse continuing time: 11ms; Pulse wave: half-sine IEC 60068-2-27
Bump Test	a=20g; Pulse continuing time: 16ms; Pulse wave: half-sine IEC 60255-21-2
Safety Requirements	Based on EN 61010-1 mounting category (over voltage) III, 300V, pollution class 2, altitude 3000m
Case Dimension	242mm x 186mm x 53mm
Panel Cutout	214mm x 160mm
CT Secondary Current	Rated 5A















Item	Contents
Working Temperature	(-40~+70)°C
Working Humidity	(20~93)%RH
Storage Temperature	(-40~+80)°C
Protection Level	IP65: when rubber seal installed between the controller enclosure and panel fascia.
Insulating Intensity	Apply AC2.2kV between high volt terminal and low volt terminal; The leakage current is not more than 3mA within 1min.
Weight	1.0kg



SmartGen



5 OPERATION

5.1 KEY FUNCTION

Table 5 - Key Description

Icon	Key	Description
	Stop/Reset	Stop running generator in Auto/Manual mode; Reset alarms in stop mode; Press for over 3s to test whether panel indicators are normal (lamp test); During stopping process, press this key again to stop generator immediately.
	Start	Start genset in Manual mode.
	Manual Mode	Press this key and put controller in Manual mode.
	Auto Mode	Press this key and put controller in Auto mode.
	Alarm Mute	Remove alarm sound; If there is trip alarm, pressing this key at least 3 seconds can reset this alarm.
	Close	Control breaker to close in manual mode.
	Open	Control breaker to open in manual mode.
	Set	Enter setting interface.
	Up/Increase	1. Screen scroll; 2. Move up cursor and increase value in setting menu.
	Down/Decrease	1. Screen scroll; 2. Move down cursor and decrease value in setting menu.
	Left	1. Page scroll; 2. Left move cursor in setting menu.
	Right	1. Page scroll; 2. Right move cursor in setting menu.

Icon	Key	Description
	Confirm	In settings menu, confirm the set value.
	Exit	1. Return to the first screen; 2. In settings menu return to previous level menu.

NOTE: In manual mode, press  and  simultaneously and genset can be forced to start. At this time, controller won't judge whether genset has been started according to crank disconnect conditions, but starter separation is controlled by operator. When operator observes genset has been started, release the keys, start output will be stopped and controller will enter Safety On Delay.

CAUTION: Fault password is "00318", operator can change the password to prevent others changing advanced configurations randomly. Please remember the password clearly after change. In case that you forget it, please contact company personnel and feedback PD information in ABOUT page to service personnel.

5.2 CONTROLLER PANEL



Fig. 1 - Controller Front Panel

NOTE: Partial indicators illustration:

Table 6 - Alarm Indicators



Alarm Type	Alarm Indicator
No Alarm	Indicator off
Warning Alarm	Slow flashing (1 time/s)
Trip Alarm	Slow flashing (1 time/s)
Shutdown Alarm	Fast flashing (5 times/s)
Trip and Stop Alarm	Fast flashing (5 times/s)

NOTE 1: Status indicator: It is light on from crank disconnect to ETS while off during other periods.

NOTE 2: Gen normal Indicator: It is light on when generator is normal; flashing when generator status is abnormal; off when there is no generator power.

5.3 LCD DISPLAY

5.3.1 MAIN DISPLAY

Main screen show pages; use  to scroll the pages and  to scroll the screens.

★**Main Screen** includes following contents:

- 1) Partial status display;
- 2) AC Gens: voltage, frequency,
- 3) AC Load: current, active power, reactive power, power factor;
- 4) DC Gens: voltage, current, power;
- 5) Engine: speed, temperature, oil pressure.

▲**NOTE:** It will screen scroll display circularly if screen scroll operation is not done after entering the main screen.

★**Status** includes,

Status of genset and ATS.

★**Engine** includes,

Speed, temperature of engine, engine oil pressure, fuel level, Configurable Sensor 1, Configurable Sensor 2, battery voltage, charger voltage, accumulated run time, accumulated start times, user A and user B accumulated start times.

▲**NOTE:** If engine information is read by J1939 via CAN BUS port, then Engine page also includes: coolant pressure, coolant level, fuel temperature, fuel pressure, inlet temperature, outlet temperature, turbo pressure, fuel consumption, total fuel consumption etc. (Different engines include different data.)

★**AC Gens** includes,

Phase voltage, Line voltage, frequency, phase sequence.

★**AC Load** includes,

Current of each phase, each phase and total active power (positive and negative), each phase and total reactive power (positive and negative), each phase and total apparent power, each phase and average power factor (positive and negative), accumulated electric energy, earth current and user A and user B accumulated electric energy.

▲**NOTE:** Power factor shows as following,

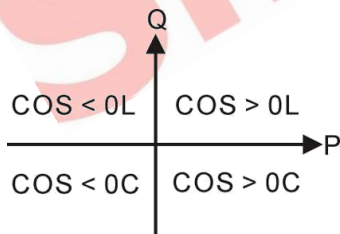

Remark:

P stands for active power

Q stands for reactive power

Table 7 - Power Factor Descriptions

Power Factor	Conditions	Active Power	Reactive Power	Remark
COS>0L	P>0,Q>0	Input	Input	Load is inductive resistance.
COS>0C	P>0,Q<0	Input	Output	Load is capacitance resistance.
COS<0L	P<0,Q>0	Output	Input	Load equals to one under excitation generator
COS<0C	P<0,Q<0	Output	Output	Load equals to one over excitation generator.

Remark:

1. Input active power, genset supplies electricity to load.
2. Output active power, load supplies electricity to genset.
3. Input reactive power, genset sends reactive power to load.
4. Output reactive power, load sends reactive power to genset.

★**DC GENS** includes,

Voltage, current, power and accumulated electric energy.

★**Alarm** includes,

Displays all alarm information, including warning, alarm shutdown, trip and stop, trip.

▲**NOTE:** For ECU warning and shutdown alarms, if the detailed alarm information is displayed, check engine according to it, otherwise, please check the manual of generator according to SPN alarm code.

★**Event log** includes,

Records all start/stop events (shutdown alarm, trip and stop alarm, manual/auto start or stop) and the real time when alarm occurs.

★**Others** includes,

Time and date, count down time for maintenance, input/output ports status, NET status etc.

★**About** includes,

Released software and hardware versions and PD number of controller.

5.3.2 PARARMETERS SETTING MENU

Press  to enter user menu;

Parameter Setting: After entering the correct password (factory default password is 00318) you can enter parameter settings screen.

Language: Selectable Chinese, English.

Commissioning: On load, off load and custom commissioning are optional. Custom commissioning can be configured to on load or not, commissioning time and which mode to return to after commissioning (manual mode, auto mode and stop mode).

Clear accumulations: Can clear total running time A and B, total electric energy A and B.

5.3.3 PARAMETER SETTINGS

- DC generator settings
- Timers settings
- Engine settings
- AC generator settings
- AC load settings
- Breaker settings

- Temperature sensor settings
- Oil pressure sensor settings
- Level sensor settings
- Flexible sensor 1 settings
- Flexible sensor 2 settings
- Digital inputs settings
- Relay outputs settings
- Module settings
- Scheduling and maintenance settings
- Expansion module settings

NOTE: Pressing  can exit settings directly during setting.

5.4 AUTO START/STOP OPERATION

Press , its indicator light is on, which means controller enters **Auto** mode.

Auto Starting Sequence:

- 1) **HGM8110DC-1:** Generator enters into “Start Delay” as soon as “Remote Start on Load” input is active.
- 2) Start delay timer is shown on LCD.
- 3) When start delay is over, preheat relay outputs (if this be configured), “Preheat Delay XX s” is shown on LCD.
- 4) When preheat delay is over, fuel relay outputs for 1s and then starter relay outputs; if engine crank fails during “Cranking Time”, the fuel relay and starter relay are deactivated and enters into “Crank Rest Time” to wait for next crank.
- 5) If engine crank fails within set start attempts, controller sends “Fail to Start” signals and “Fail to Start” message appears on LCD alarm page.
- 6) In case of successful crank attempt, “Safety on Time” starts. During this period, low oil pressure, high water temperature, under speed, charge failure alarms are disabled. As soon as this delay is over, “Start Idle Delay” is initiated (if configured).
- 7) During “Start Idle Delay”, under speed, under frequency, under voltage alarms are inhibited. When this delay is over, “Warming Up Delay” starts (if configured).
- 8) When “Warming Up Delay” is over, if generator status is normal, its indicator will be illuminated. If voltage and frequency has reached on-load requirements, the close relay will be energized, generator will accept load, generator power indicator will turn on, and generator will enter Normal Running state; if voltage and frequency are abnormal, the controller will initiate shutdown alarm (alarm type will be displayed on LCD alarm page).

NOTE: In case of “Remote Start (off Load)”, the procedure is the same, except for step No. 8: the close relay will NOT be energized, generator will NOT accept load.

Auto Stopping Sequence:



- 1) **HGM8110DC-1,** generator enters into “Stop Delay” as soon as “Remote Start” is inactive.
- 2) When stop delay is over, close generator relay is un-energized; generator enters into “Cooling Time”. Generator indicator extinguishes.
- 3) Idle relay is energized as soon as entering “Stop Idle Delay”.
- 4) If enter “ETS Hold Delay”, ETS relay is energized. Fuel relay is deactivated and decides whether generator is stopped or not automatically.
- 5) Then enter genset “Fail to Stop Time”, it decides whether generator is stopped or not automatically.
- 6) Enter “After Stop Time” (if configured) as soon as generator stops. Otherwise, controller enters stop

failure and sends "Fail to Stop Time" warning alarm at the same time. (If genset stops successfully after warning of "Failed to Stop", it will enter "After Stop Time" and removes alarm automatically.)

7) Enter "Generator at Rest" as soon as "After Stop Time" is over.

5.5 MANUAL START/STOP OPERATION

1) **MANUAL START:** Press , controller enters into manual mode and its indicator is light on. Press

 to start generator, it can automatically detect crank disconnect, and generator accelerates to high-speed running automatically. If high water temperature, low oil pressure, over speed and abnormal voltage during generator running, controller can protect genset to stop quickly. Press  and  to open or close the switch. (Please refer to No.3~8 of Auto start operation for detail procedures, where the only difference is the way of switch open and close).

2) **MANUAL STOP:** Press  and it can stop the running generators. (Please refer to No.2~7 of Auto stop operation for detail procedures).

▲NOTE: In "manual mode", the procedures of ATS please refer to ATS procedure of generator in this manual.

5.6 GENSET CONTROLLER SWITCH CONTROL PROCEDURES

5.6.1 MANUAL CONTROL PROCEDURES

When controller is in manual mode, manual control procedure is conducted for switch control. Users can control switch on or off by pressing close/open key.

Press generator close key , and close outputs; Press generator open key , generator open outputs.

5.6.2 AUTO CONTROL PROCEDURES

When controller is in auto mode, auto control procedure will be conducted for switch control.

1) If input port is configured as "Gen Closed Auxiliary"

A. If "Open Check" is enabled;

Generator on-load is transferred into generator off-load, after the delay of switch off, transfer failure starts to detect at the same time of open output. When detecting time is out, if switch off failed, it will wait for switch off. Otherwise, switch off is completed.

Generator off-load is transferred into generator on-load, after the delay of switch on, transfer failure starts to detect at the same time of close output. When detecting time is out, if switch on failed, it will wait for switch on. Otherwise, switch on is completed.

If transfer failure warning is enabled, warning signal will be issued for close/open failures.

B. If "Open Check" is disabled;

Generator on-load is transferred into generator off-load, after the delay of switch off, switch off is completed.

Generator off-load is transferred into generator on-load, after the delay of switch on, transfer failure starts to detect at the same time of close output. When detecting time is out, if switch on failed, it will wait for switch on. Otherwise, switch on is completed.

If transfer failure warning is enabled, warning signal will be issued for close failure.

2) If input port is not configured as "Gen Closed Auxiliary"

Generator off-load is transferred into generator on-load, close generator outputs. Generator on-load is transferred into generator off-load, open generator outputs.

▲NOTES:

- 1) When ATS of none neutral position is used, Open Check shall be disabled.
- 2) When ATS with neutral positions is used, Open Check can be enabled or disabled; If it is enabled, please configure open output;
- 3) When AC contactor is used, Open Check is recommended.

6 PROTECTION

6.1 WARNING ALARMS

When controller detects the warning signals, it sends alarm only and not stop the genset.

Table 8 - Warning Alarms

No.	Type	Action Range	Description
1	Over Speed	Always active	When controller detects the speed is higher than the set value, it will send warn signals.
2	Under Speed	Active from start idle to stop idle, inactive for others	When controller detects the speed is lower than the set value, it will send warn signals.
3	Loss of Speed Signal	Active from start idle to cooling period; transfer to ETS immediately at alarms	When controller detects the speed is 0 and the action selects "Warn", it will send warn signals.
4	AC Over Frequency	Always active	When controller detects the frequency of AC genset is higher than the set value, it will send warn signals.
5	AC Under Frequency	Active from wait for load to stop cooling	When controller detects the frequency of AC genset is lower than the set value, it will send warn signals.
6	AC Over Voltage	Always active	When controller detects the voltage of AC genset is higher than the set value, it will send warn signals.
7	AC Under Voltage	Active from wait for load to stop cooling	When controller detects the voltage of AC genset is lower than the set value, it will send warn signals.
8	AC Over Current	Always active	When controller detects the current of AC genset is higher than the set value and the action selects "Warn", it will send warn signals.
9	Fail to Stop	Active after failed to stop	When generator not stops after the "stop delay" is over, it will send warn signals.
10	Charge Alt Failure	Active at normal running	When controller detects the charger voltage is lower than the set value, it will send warn signals.
11	Battery Over Voltage	Always active	When controller detects the battery voltage is higher than the set value, it will send warn signals.
12	Battery Under Voltage	Always active	When controller detects the battery voltage is lower than the set value, it will send warn signals.
13	Maintenance Due	Active when maintenance	When count down time is 0 and the action



No.	Type	Action Range	Description
		time is due	selects "Warn", it will send warn signals.
14	AC Reverse Power	Always active	When controller detects the reverse power value (power is negative) is higher than the set value and the action selects "Warn", it will send warn signals.
15	AC Over Power	Always active	When controller detects the reverse power value (power is positive) is higher than the set value and the action selects "Warn", it will send warn signals.
16	ECU Warn	Active when ECU receives yellow indicator alarm	When controller gets the alarm signals from engine via J1939, it will send warn signals.
17	AC Loss of Phase	Detected when Phase voltage>30V, Line voltage>50V	When controller detects the AC generator loss phase, it will send warn signals.
18	AC Phase Sequence Wrong	Detected when Phase voltage>30V, Line voltage>50V	When controller detects the AC generator phase rotation, it will send warn signals.
19	Switch Failure	Active when switch close failed	When controller detects the switch on and off fail, and the action select enable, it will send warn signals.
20	DC Over Voltage	Always active	When controller detects the voltage of DC genset is higher than the set value, it will send warn signals.
21	DC Under Voltage	Active from wait for load to stop cooling	When controller detects the voltage of DC genset is lower than the set value, it will send warn signals.
22	DC Over Current	Always active	When controller detects the current of DC genset is higher than the set value and the action selects "Warn", it will send warn signals.
23	DC Over Power	Always active	When controller detects the reverse power value (power is positive) is higher than the set value and the action selects "Warn", it will send warn signals.
24	Temp. Sensor Open	Always active	When controller detects the sensor is open circuit, and the action selects "Warn", it will send warn signals.
25	High Temp. Warn	Active from start idle to stop idle	When controller detects the temperature is higher than the set value, it will send warn signals.
26	Oil Pressure Sensor Open	Always active	When controller detects sensor open and open action selects "Warn", it will send warning signal.
27	Low OP Warn	Active from start idle to	When controller detects the oil pressure is



No.	Type	Action Range	Description
		stop idle	lower than the set value, it will send warn signals.
28	Level Sensor Open	Always active	When controller detects the sensor is open circuit, and the action selects "Warn", it will send warn signals.
29	Low Level Warn	Always active	When controller detects the oil lever is lower than the set value, it will send warn signals.
30	Flexible Sensor 1 Open	Always active	When controller detects the sensor is open circuit, and the action selects "Warn", it will send warn signals.
31	Flexible Sensor 1 High	Active from start idle to stop idle	When controller detects the sensor value is higher than the max. set value, it will send warn signals.
32	Flexible Sensor 1 Low	Active from start idle to stop idle	When controller detects the sensor value is lower than the min. set value, it will send warn signals.
33	Flexible Sensor 2 Open	Always active	When controller detects the sensor is open circuit, and the action selects "Warn", it will send warn signals.
34	Flexible Sensor 2 High	Active from start idle to stop idle	When controller detects the sensor value is higher than the max. set value, it will send warn signals.
35	Flexible Sensor 2 Low	Active from start idle to stop idle	When controller detects the sensor value is lower than the min. set value, it will send warn signals.
36	Digital Input Warn	Custom alarm zone	When digit input port is set as warning and active, controller sends corresponding warning signals.
37	Earth Fault	Always active	When controller detects earth current is greater than value of setting, and the action "Warn" alarm is set, it will send a warning alarm signals.

6.2 SHUTDOWN ALARM

When controller detects shutdown alarm, it will disconnect Gens close signal and stop the generator immediately.

Table 9 - Shutdown Alarms

No.	Type	Action Range	Description
1	Emergency Stop	Always active	When controller detects emergency stop signals, it will send stop signals.
2	Over Speed	Always active	When controller detects the speed value is higher than the set value, it will send stop signals.
3	Under Speed	Active from wait for load to stop cooling	When controller detects the speed value is lower than the set value, it will send stop signals.
4	Loss of Speed Signal	Active from start idle to stop idle	When controller detects speed value equals to 0, and the action selects "Shutdown", it will send stop signals
5	AC Over Frequency	Always active	When controller detects the frequency value of AC genset is higher than the set value, it will send stop signals.
6	AC Under Frequency	Active from wait for load to stop cooling	When controller detects the frequency value of AC genset is lower than the set value, it will send stop signals.
7	AC Over Voltage	Always active	When controller detects the voltage value of AC genset is higher than the set value, it will send stop signals.
8	AC Under Voltage	Active from wait for load to stop cooling	When controller detects the voltage value of AC genset is lower than the set value, it will send stop signals.
9	Fail to Start	Active after failed to start	If genset start failure within setting of start times, controller will send stop signals.
10	AC Over Current	Always active	When controller detects the current value of AC genset is higher than the set value, it will send stop signals.
11	Maintenance Due	Active when maintenance time is due	When count down time is 0 and the action selects "Shutdown", it will send stop signals.
12	ECU Shutdown	Active when controller receives ECU red indicator alarm	When controller receives engine shutdown signals via J1939, controller send stop signals.
13	ECU Comm. Fail Shutdown	Active when controller failed to comm. with ECU	After engine start, controller does not receive data signals, via J1939, controller send stop signals.
14	AC Reverse Power Shutdown	Always active	When controller detects reverse power value of AC genset (power is negative) is higher



No.	Type	Action Range	Description
			than the set value, and the reverse power action selects "shutdown", it will send stop signals.
15	AC Over Power Shutdown	Always active	When controller detects reverse power value of AC genset (power is positive) is higher than the set value, and the reverse power action selects "shutdown", it will send stop signals.
16	DC Over Voltage	Always active	When controller detects the voltage value of DC genset is higher than the set value, it will send stop signals.
17	DC Under Voltage	Active from wait for load to stop cooling	When controller detects the voltage value of DC genset is lower than the set value, it will send stop signals.
18	DC Over Current	Always active	When controller detects the current value of DC genset is higher than the set value, it will send stop signals.
19	DC Over Power Shutdown	Always active	When controller detects reverse power value of DC genset (power is positive) is higher than the set value, and the reverse power action selects "shutdown", it will send stop signals.
20	Temp. Sensor Open	Always active	When controller detects sensor is open circuit, and the action selects "shutdown", it will send stop signals.
21	High Temp. Shutdown	Active from start idle to stop idle	When controller detects temperature is higher than the set value, it will send stop signals.
22	Pressure Sensor Open	Always active	When controller detects sensor is open circuit, and the action selects "shutdown", it will send stop signals.
23	Low Oil Pressure	Active from start idle to stop idle	When controller detects oil pressure is lower than the set value, it will send stop signals.
24	Level Sensor Open	Always active	When controller detects sensor is open circuit, and the action selects "shutdown", it will send stop signals.
25	Flexible Sensor 1 Open	Always active	When controller detects sensor is open circuit, and the action selects "shutdown", it will send stop signals.
26	Flexible Sensor 1 High	Active from start idle to stop idle	When controller detects the sensor value is higher than the max. set value, it will send stop signals.
27	Flexible Sensor 1 Low	Active from start idle to stop idle	When controller detects the sensor value is lower than the min. set value, it will send



No.	Type	Action Range	Description
			stop signals.
28	Flexible Sensor 2 Open	Always active	When controller detects sensor is open circuit, and the action selects "shutdown", it will send stop signals.
29	Flexible Sensor 2 High	Active from start idle to stop idle	When controller detects the sensor value is higher than the max. set value, it will send stop signals.
30	Flexible Sensor 2 Low	Active from start idle to stop idle	When controller detects the sensor value is lower than the min. set value, it will send stop signals.
31	Digital Input Port Shutdown	Custom active period	When digital input port is set as shutdown, and the action is active, it will send stop signals.
32	Earth Fault	Always active	When controller detects the earth current of genset exceeds preset earth fault threshold and the earth fault action selects "shutdown" it will send stop signals.

SmartGen

6.3 TRIP AND STOP ALARM

When controller detects trip and stop alarm signals, it will disconnect Gens close signal and stop the generator after cooling.

Table 10 - Trip and Stop Alarms

No.	Type	Action Range	Description
1	AC Over Current	Always active	When controller detects the current value of AC genset is higher than the set value, and the action selects "trip and stop", it will send trip and stop signals.
2	Maintenance Due	Active when maintenance time is due	When count down time is 0 and the action selects "trip and stop", it will send a trip and stop signals.
3	AC Reverse Power	Always active	When controller detects reverse power value of AC genset (power is negative) is higher than the set value, and the action selects "trip and stop", it will send a trip and stop signals.
4	AC Over Power	Always active	When controller detects the reverse power value of AC genset (power is positive) is higher than the set value, and the action selects "trip and stop", it will send a trip and stop signals.
5	DC Over Current	Always active	When controller detects the current value of DC genset is higher than the set value, and the action selects "trip and stop", it will send trip and stop signals.
6	DC Over Power	Always active	When controller detects the over power value of DC genset (power is positive) is higher than the set value, and the action selects "trip and stop", it will send a trip and stop signals.
7	Digital Input Ports	Custom active period	When digital input port is set as "trip and stop", and the action is active, it will send a trip and stop signals.
8	Earth Fault	Always active	When controller detects the earth current of genset exceeds preset earth fault threshold and the earth fault action selects "trip and stop" it will send trip and stop signals.

6.4 TRIP ALARM

When controller detects trip alarm, it will disconnect Gens close signal immediately but genset won't stop.

Table 11 - Trip Alarms

No.	Type	Action Range	Description
1	AC Over Current	Always active	When controller detects the current value of AC genset is higher than the set value, and the action selects "trip", it will send trip signals.
2	AC Reverse Power	Always active	When controller detects reverse power value (power is negative) is higher than the set value, and the action selects "trip", it will send a trip signals.
3	AC Over Power	Always active	When controller detects the power value of AC genset (power is positive) is higher than the set value, and the action selects "trip", it will send a trip signals.
4	DC Over Current	Always active	When controller detects the current value of DC genset is higher than the set value, and the action selects "trip", it will send trip signals.
5	DC Over Power	Always active	When controller detects the over power value of DC genset (power is positive) is higher than the set value, and the action selects "trip", it will send a trip signals.
6	Digital Input Ports	Custom active period	When digital input port is set as "trip", and the action is active, it will send a trip signals.
7	Earth Fault	Always active	When controller detects the earth current of genset exceeds preset earth fault threshold and the earth fault action selects "trip" it will send a trip signals.

7 WIRINGS CONNECTION

HGM8110DC-1 controller's back panel is as below:

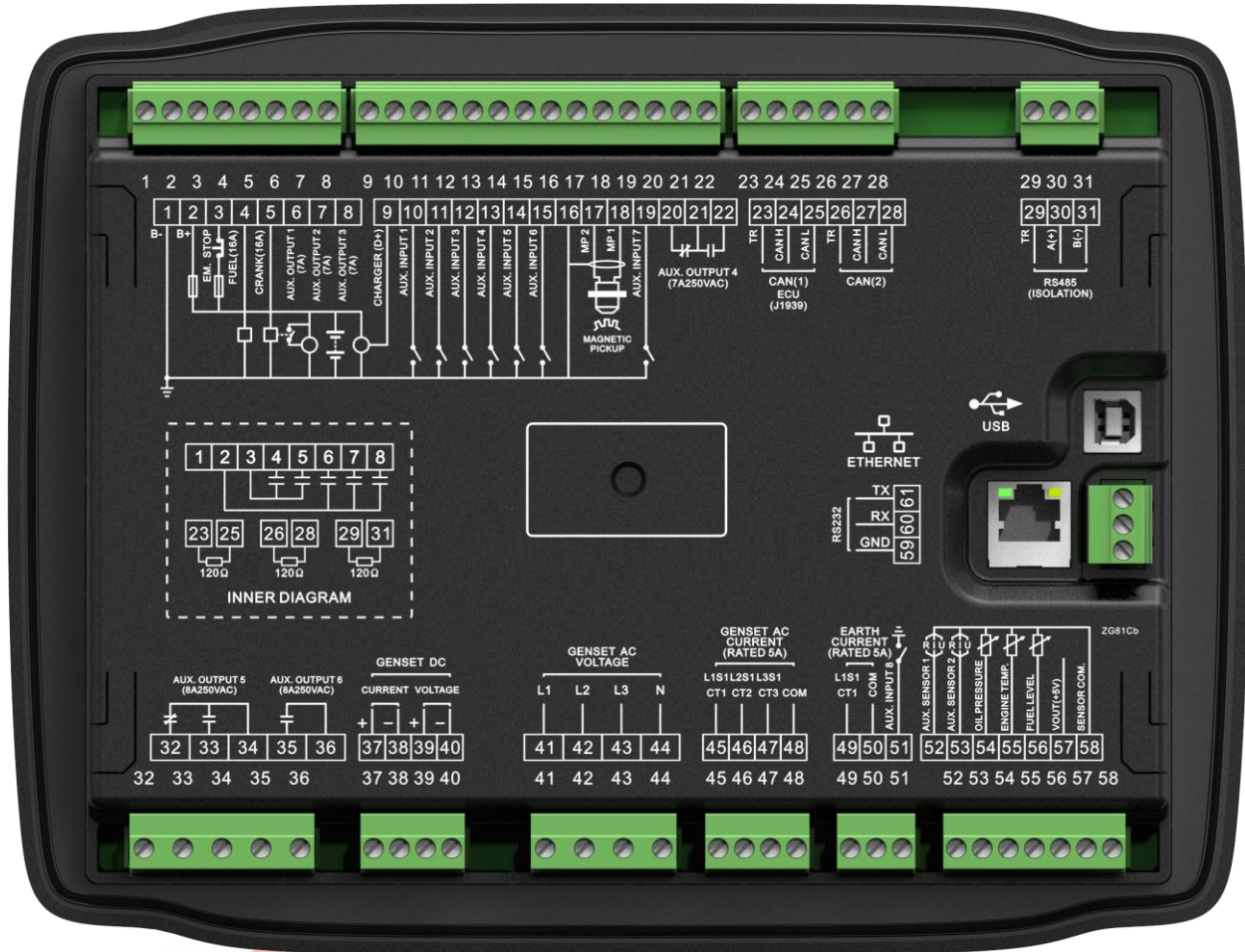

Fig.2 - Controller Back Panel Diagram

Table 12 - Terminal Wiring Connection

No.	Function	Cable Size	Remarks
1	B-	2.5mm ²	Connected with negative of starter battery.
2	B+	2.5mm ²	Connected with positive of starter battery. If wire length is over 30m, better to double wires in parallel. Max. 20A fuse is recommended.
3	Emergency stop	2.5mm ²	Connected with B+ via emergency stop button.
4	Fuel relay output	1.5mm ²	B+ is supplied by No.3 terminal, rated 16A.
5	Starter relay output	1.5mm ²	B+ is supplied by No.3 terminal, rated 16A. Connected to starter coil.
6	Aux. Output 1	1.5mm ²	B+ is supplied by No.2 terminal, rated 7A.
7	Aux. Output 2	1.5mm ²	B+ is supplied by No.2 terminal, rated 7A. Details see Table 14.
8	Aux. Output 3	1.5mm ²	B+ is supplied by No.2 terminal, rated 7A.



No.	Function	Cable Size	Remarks
9	Charger(D+)	1.0mm ²	Connected with charge alternator's D+ (WL) terminals. Being hang up if there is no this terminal.
10	Aux. Input 1	1.0mm ²	Ground connected is active (B-).
11	Aux. Input 2	1.0mm ²	Ground connected is active (B-).
12	Aux. Input 3	1.0mm ²	Ground connected is active (B-).
13	Aux. Input 4	1.0mm ²	Ground connected is active (B-).
14	Aux. Input 5	1.0mm ²	Ground connected is active (B-).
15	Aux. Input 6	1.0mm ²	Ground connected is active (B-).
16	Magnetic Pickup	0.5mm ²	Connected with Speed sensor, shielding line is recommended. (B-) has already connected with speed sensor 2 inside the controller.
17	MP 2		
18	MP 1		
19	Aux. Input 7	1.0mm ²	Ground connected is active (B-).
20	Aux. Output 4	1.5mm ²	Normally close output, rated 7A.
21			Relay common port.
22			Normally open output, rated 7A.
23	ECU CAN Internal Resistance		Impedance-120Ω shielding wire is recommended, its single-end earthed. (120Ω resistor is connected inside for Terminal 23 and Terminal 25; short connect Terminal 23 and Terminal 24 at using.)
24	ECU CAN H	0.5mm ²	
25	ECU CAN L	0.5mm ²	
26	CAN2 Internal Resistance		Impedance-120Ω shielding wire is recommended, its single-end earthed. (120Ω resistor is connected inside for Terminal 26 and Terminal 28; short connect Terminal 26 and Terminal 27 at using.)
27	CAN2 H	0.5mm ²	
28	CAN2 L	0.5mm ²	
29	RS485 Internal Resistance	/	Impedance-120Ω shielding wire is recommended, its single-end earthed. (120Ω resistor is connected inside for Terminal 29 and Terminal 31; short connect Terminal 29 and Terminal 30 at using.)
30	RS485A(+)	0.5mm ²	
31	RS485B(-)	0.5mm ²	
32	Aux. Output 5	2.5mm ²	Normally close output, rated 8A.
33		2.5mm ²	Normally open output, rated 8A.
34		2.5mm ²	Relay common port.
35	Aux. Output 6	2.5mm ²	Normally open output, rated 8A.
36		2.5mm ²	Relay common port.
37	DC Current +	1.0mm ²	External connected to DC positive of current transmitter.
38	DC Current -	1.0mm ²	External connected to DC negative of current transmitter
39	DC Voltage +	1.0mm ²	External connected to DC positive of voltage transmitter
40	DC Voltage -	1.0mm ²	External connected to DC negative of voltage transmitter.
41	AC Gen A-Phase Volt Input	1.0mm ²	Connected to A-phase of AC genset (2A fuse is recommended).
42	AC Gen B-Phase Volt Input	1.0mm ²	Connected to B-phase of AC genset (2A fuse is recommended).
43	AC Gen C-Phase Volt Input	1.0mm ²	Connected to C-phase of AC genset (2A fuse is recommended).



No.	Function	Cable Size	Remarks	
44	AC Gen N-Line Volt Input	1.0mm ²	Connected to N-line of AC genset.	
45	AC CT A-Phase Input	1.5mm ²	External connected to secondary coil of current transformer (rated 5A).	
46	AC CT B-Phase Input	1.5mm ²	External connected to secondary coil of current transformer (rated 5A).	
47	AC CT C-Phase Input	1.5mm ²	External connected to secondary coil of current transformer (rated 5A).	
48	AC CT COM	1.5mm ²	See following installation instruction.	
49	Earth Current	1.5mm ²	External connected to secondary coil of current transformer (rated 5A).	
50		1.5mm ²		
51	Aux. Input 8	1.0mm ²	Ground connected is active (B-).	Details see Table 15.
52	Aux. Sensor 1	1.0mm ²	Connected to temperature, oil pressure or fuel level sensors; Voltage type (0-5V), Current type (4-20mA) and Resistance sensors	Details see Table 16.
53	Aux. Sensor 2	1.0mm ²		
54	Oil Pressure Sensor	1.0mm ²		
55	Temperature Sensor	1.0mm ²		
56	Fuel Level Sensor	1.0mm ²		
57	VOUT(+5V)	1.0mm ²	+5V output, used to supply power for voltage type sensor.	
58	Sensor COM	/	Sensor common port, controller internal has been connected to negative of battery.	
59	RS232 COM	0.5mm ²	RS232 port	
60	RS232 RX	0.5mm ²		
61	RS232 TX	0.5mm ²		

NOTE1: USB ports in controller rear panel are programmable parameter ports, user can directly configure controller via PC.

NOTE2: Ethernet ports in controller rear panel are website ports, user can directly configure and monitor controller via PC.

8 SCOPES AND DEFINITIONS OF PROGRAMMABLE PARAMETERS

8.1 CONTENTS AND SCOPES OF PARAMETERS

Table 13 - Parameters Contents and Scopes

No.	Items	Parameters Range	Defaults	Description
DC Generator				
1	Work Mode	(0~2)	0	0: DC; 1: AC; 2: DC+AC;
2	Rated Voltage	(10~30000)V	500	Standard for checking DC generator over/under voltage.
3	Loading Voltage	(0~100)%	90	Setting value is DC generator rated voltage's percentage. The controller detects in the preparation of the load period, and does not enter the normal running period when the generator voltage is less than the load voltage.
4	PT Ratio	(10~30000)V/10V	1000	Ratio of the external connected DC voltage transformer.
5	Rated Current	(10~6000)A	300	Rated full load current of DC generator, which is used as the standard for load current.
6	CT Ratio	(10~6000)A/20mA	400	Ratio of the external connected DC current transformer.
7	Rated Power	(10~6000)kW	100	It is rated power for DC generator, which is used as the standard for load power.
8	Over Voltage Shutdown	0: Disable 1: Enable	1	Alarm is detected after enabled; not detected if it is disabled.
		(0~200)%	120	Set value is DC generator rated voltage's percentage, alarm starts if it is above the set value.
		(0~3600)s	1	Alarm starts when voltage gets up to the alarm value and this delay is expired.
9	Under Voltage Shutdown	0: Disable 1: Enable	1	Alarm is detected after enabled; not detected if it is disabled.
		(0~200)%	80	Set value is DC generator rated voltage's percentage, alarm starts if it is below the set value.
		(0~3600)s	1	Alarm starts when voltage gets up to the alarm value and this delay is expired.
10	Over Voltage Warn	0: Disable 1: Enable	1	Alarm is detected after enabled; not detected if it is disabled.
		(0~200)%	110	Set value is DC generator rated voltage's



No.	Items	Parameters Range	Defaults	Description
				percentage, alarm starts if it is above the set value.
		(0~200)%	105	Set value is DC generator rated voltage's percentage; when alarm is active, and voltage is below the return value, alarm can be cleared automatically.
		(0~3600)s	5	Alarm starts when voltage gets up to the alarm value and this delay is expired.
11	Under Voltage Warn	0: Disable 1: Enable	0	Alarm is detected after enabled; not detected if it is disabled.
		(0~200)%	90	Set value is DC generator rated voltage's percentage, alarm starts if it is below the set value.
		(0~200)%	95	Set value is DC generator rated voltage's percentage; when alarm is active, and voltage is above the return value, alarm can be cleared automatically.
		(0~3600)s	5	Alarm starts when voltage gets up to the alarm value and this delay is expired.
12	Over Current	0: Disable 1: Enable	1	Alarm is detected after enabled; not detected if it is disabled.
		(0~200)%	110	Set value is DC generator rated current's percentage, alarm starts if it is above the set value.
		0: Warn 1: Shutdown 2: Trip and Stop 3: Trip	0	Alarm type is optional; if alarm is active, handle the alarm based on alarm type.
		(0~3600)s	5	Alarm starts when current gets up to the alarm value and this delay is expired.
13	Over Power	0: Disable 1: Enable	1	Alarm is detected after enabled; not detected if it is disabled.
		(0~200)%	110	Set value is DC generator rated power's percentage, alarm starts if it is above the set value.
		(0~200)%	90	Set value is DC generator rated power's percentage; when alarm is active, and voltage is below the return value, alarm can be cleared automatically.
		0: Warn 1: Shutdown 2: Trip and Stop 3: Trip	0	Alarm type is optional; if alarm is active, handle the alarm based on alarm type.
		(0~3600)s	5	Alarm starts when power gets up to the



No.	Items	Parameters Range	Defaults	Description
				alarm value and this delay is expired.
Timers				
1	Start Delay	(0~3600)s	1	Time from mains abnormal or remote start signal is active to genset start.
2	Stop Delay	(0~3600)s	1	Time from mains normal or remote start signal is deactivated to genset stop.
3	Preheat Delay	(0~3600)s	0	Time of pre-powering heat plug before starter is powered up.
4	Cranking Time	(3~60)s	8	Time of starter power up.
5	Crank Rest Time	(3~60)s	10	The waiting time before second power up when engine start fail.
6	Safety On Delay	(0~3600)s	10	Alarms for low oil pressure, high temperature, under speed, under frequency/voltage, charge fail are inactive.
7	Start Idle Time	(0~3600)s	0	Idle running time of genset when starting.
8	Warming Up Time	(0~3600)s	10	Warming time between genset switch on and normal running.
9	Cooling Time	(0~3600)s	10	Radiating time before genset stop, after it unloads.
10	Stop Idle Time	(0~3600)s	0	Idle running time when genset stop.
11	ETS Solenoid Hold	(0~3600)s	20	The time of powering up the electromagnet during stop procedure.
12	Wait Stop Delay	(0~3600)s	0	Time between ending of genset idle delay and stopped when "ETS time" is set as 0; Time between ending of ETS hold delay and stopped when "ETS Hold output time" is not 0.
13	After Stop Time	(0~3600)s	0	Time between genset stopped and standby.
Engine				
1	Engine Type	(0~39)	0	Default: Non ECU engine When connected to J1939 engine, choose the corresponding type.
2	Flywheel Teeth	(10~300)	118	Tooth number of the engine, for judging of crank disconnect conditions and inspecting of engine speed. See the installation instructions.
3	Rated Speed	(0~6000)r/min	1500	Offer standard to judge over/under/loading speed.
4	Speed On Load	(0~100)%	90	Setting value is percentage of rated speed. Controller detects when it is ready to load. It won't switch on when speed is under loading speed.
5	Loss of Speed	(0~3600)s	5	Time from detecting speed is 0 to confirm



No.	Items	Parameters Range	Defaults	Description
	Signal Delay			the action.
6	Loss of Speed Signal	(0~1)	0	0: Warning; 1: Shutdown
7	Over Speed Shutdown	0: Disable 1: Enable	1	Start to detect alarms when it is enabled; not detect alarms when disabled;
		(0~200)%	114	Set value is percentage of rated speed; start alarm handle when it is above this value.
		(0~3600)s	2	Alarm starts when speed reaches alarm value and this delay time is expired.
8	Under Speed Shutdown	0: Disable 1: Enable	1	Start to detect alarms when it is enabled; not detect alarms when disabled.
		(0~200)%	80	Set value is percentage of rated speed; start alarm handle when it is below this value.
		(0~3600)s	3	Alarm starts when speed reaches alarm value and this delay time is expired.
9	Over Speed Warn	0: Disable 1: Enable	1	Start to detect alarms when it is enabled; not detect alarms when disabled;
		(0~200)%	110	Set value is percentage of rated speed; start alarm handle when it is above this value.
		(0~200)%	108	Set value is percentage of rated speed; when alarm is active, and speed is below return value, alarm can be cleared automatically.
		(0~3600)s	5	Alarm starts when speed reaches alarm value and this delay time is expired.
10	Under Speed Warn	0: Disable 1: Enable	1	Start to detect alarms when it is enabled; not detect alarms when disabled;
		(0~200)%	86	Set value is percentage of rated speed; start alarm handle when it is below this value.
		(0~200)%	90	Set value is percentage of rated speed; when alarm is active, and speed is above return value, alarm can be cleared automatically.
		(0~3600)s	5	Alarm starts when speed reaches alarm value and this delay time is expired.
11	Battery Rated Voltage	(0~60.0)V	24.0	Standard for detecting over/under voltage of battery.
12	Battery Over Volt Warn	0: Disable 1: Enable	1	Start to detect alarms when it is enabled; not detect alarms when disabled.
		(0~200)%	120	Set value is percentage of battery voltage;



No.	Items	Parameters Range	Defaults	Description
				start alarm handle when it is above this value.
		(0~200)%	115	Set value is percentage of battery rated voltage; when alarm is active and battery voltage is below return value, alarm can be cleared automatically.
		(0~3600)s	60	Alarm starts when voltage reaches alarm value and this delay time is expired.
13	Battery Under Volt Warn	0: Disable 1: Enable	1	Start to detect alarms when it is enabled; not detect alarms when disabled.
		(0~200)%	85	Set value is percentage of battery voltage; start alarm handle when it is below this value.
		(0~200)%	90	Set value is percentage of battery voltage; when alarm is active, and battery voltage is above return value, alarm can be cleared automatically.
		(0~3600)s	60	Alarm starts when battery voltage reaches alarm value and this delay time is expired.
14	Charge Alt Failure	0: Disable 1: Enable	1	Start to detect alarms when it is enabled; not detect alarms when disabled.
		(0~60.0)V	8.0	Set value is percentage of charger voltage; During genset normal running process, start alarm handle when charger D+(WL) voltage is below this value.
		(0~60.0)V	10.0	Set value is percentage of charger voltage; when alarm is active, and charger voltage is above return value, alarm can be cleared automatically.
		(0~3600)s	10	Alarm starts when charger voltage reaches alarm value and this delay time is expired.
15	Start Attempts	(1~10) times	3	Max. crank times of crank attempts. When reach this number, controller will send start failure signal.
16	Crank Disconnect	(0~6)	2	See Table 17. There are 3 conditions of disconnecting starter with engine. Each condition can be used alone and simultaneously to separate the starting motor and genset as soon as possible.
17	Disconnect Generator Freq	(0~200)%	24	Set value is percentage of gen rated frequency. When generator frequency higher than the set value, starter will be



No.	Items	Parameters Range	Defaults	Description
				disconnected. See the installation instruction.
18	Disconnect Speed	(0~200)%	24	Set value is percentage of gen rated speed. When generator's speed higher than the set value, starter will be disconnected. See the installation instruction.
19	Disconnect Oil Pressure	(0~1000)kPa	200	When generator oil pressure higher than the set value, starter will be disconnected. See the installation instruction.
AC Generator				
1	AC System	(0~3)	0	0: 3P4W; 1: 3P3W; 2: 2P3W; 3: 1P2W.
2	Poles	(2~64)	4	Numbers of generator pole, used for calculating starter rotate speed when there is not speed sensor.
3	Rated Voltage	(30~30000)V	230	To offer standards for detecting of generator' over/under voltage and loading voltage. It is primary voltage when using voltage transformer.
4	Loading Voltage	(0~200)%	85	Setting value is percentage of AC generator rated voltage. The controller detects in the preparation of the load period, and does not enter the normal running period when the generator voltage is less than the load voltage.
5	Rated Frequency	(10.0~600.0)Hz	50.0	To offer standards for detecting of over/under/load frequency.
6	Loading Frequency	(0~200)%	85	Setting value is AC generator rated frequency's percentage. The controller detects in the preparation of the load period, and does not enter the normal running period when the generator voltage is less than the load voltage.
7	PT Fitted	(0~1)	0	0: Disable; 1: Enable
	Primary Voltage	(30~30000)V	100	Primary voltage of PT.
	Secondary Voltage	(30~1000)V	100	Secondary voltage of PT.
8	Over Volt. Shutdown	0: Disable 1: Enable	1	Start to detect alarms when it is enabled; not detect alarms when disabled.
		(0~200)%	120	Set value is percentage of AC Gen rated voltage; start alarm handle when it is above this value.
		(0~3600)s	3	Alarm starts when voltage reaches alarm



No.	Items	Parameters Range	Defaults	Description
				value and this delay time is expired.
9	Under Volt. Shutdown	0: Disable 1: Enable	1	Start to detect alarms when it is enabled; not detect alarms when disabled.
		(0~200)%	80	Set value is percentage of AC Gen rated voltage; start alarm handle when it is below this value.
		(0~3600)s	3	Alarm starts when voltage reaches alarm value and this delay time is expired.
10	Over Freq. Shutdown	0: Disable 1: Enable	1	Start to detect alarms when it is enabled; not detect alarms when disabled.
		(0~200)%	114	Set value is percentage of AC Gen rated freq. start alarm handle when it is above this value.
		(0~3600)s	2	Alarm starts when freq. reaches alarm value and this delay time is expired.
11	Under Freq. Shutdown	0: Disable 1: Enable	1	Start to detect alarms when it is enabled; not detect alarms when disabled.
		(0~200)%	80	Set value is percentage of AC Gen rated freq. start alarm handle when it is below this value.
		(0~3600)s	3	Alarm starts when freq. reaches alarm value and this delay time is expired.
12	Over Volt. Warn	0: Disable 1: Enable	1	Start to detect alarms when it is enabled; not detect alarms when disabled.
		(0~200)%	110	Set value is percentage of AC Gen rated voltage; start alarm handle when it is above this value.
		(0~200)%	108	Set value is percentage of AC Gen rated voltage; when alarm is active and voltage is below return value, alarm can be cleared automatically.
		(0~3600)s	5	Alarm starts when voltage reaches alarm value and this delay time is expired.
13	Under Volt. Warn	0: Disable 1: Enable	1	Start to detect alarms when it is enabled; not detect alarms when disabled.
		(0~200)%	84	Set value is percentage of AC Gen rated voltage; start alarm handle when it is below this value.
		(0~200)%	86	Set value is percentage of AC Gen rated voltage; when alarm is active and voltage is above return value, alarm can be cleared automatically.
		(0~3600)s	5	Alarm starts when voltage reaches alarm value and this delay time is expired.



No.	Items	Parameters Range	Defaults	Description
14	Over Freq. Warn	0: Disable 1: Enable	1	Start to detect alarms when it is enabled; not detect alarms when disabled.
		(0~200)%	110	Set value is percentage of AC Gen rated freq. start alarm handle when it is above this value.
		(0~200)%	108	Set value is percentage of AC Gen rated freq. when alarm is active, and freq. is below return value, alarm can be cleared automatically.
		(0~3600)s	5	Alarm starts when freq. reaches alarm value and this delay time is expired.
15	Under Freq. Warn	0: Disable 1: Enable	1	Start to detect alarms when it is enabled; not detect alarms when disabled.
		(0~200)%	84	Set value is percentage of AC Gen rated freq. start alarm handle when it is below this value.
		(0~200)%	86	Set value is percentage of AC Gen rated freq. when alarm is active, and freq. is above return value, alarm can be cleared automatically.
		(0~3600)s	5	Alarm starts when freq. reaches alarm value and this delay time is expired.
16	Loss of Phase	(0~1)	1	0: Disable 1: Enable
17	Phase Sequence Wrong	(0~1)	1	
AC Load				
1	CT Ratio	(5~6000)A/5A	500	The ratio of external AC CT.
2	Rated Current	(5~6000)A	500	Generator's rated current, standard of load current.
3	Rated Power	(0~6000)kW	276	Generator's rated power, standard of load power.
4	Over Current	0: Disable 1: Enable	1	Start to detect alarms when it is enabled; not detect alarms when disabled.
		(0~200)%	120	Set value is percentage of AC Gen rated full load current; Delay value can be set to Definite Time or IDMT; Start alarm handle when it is above this value.
		0: Warn 1: Shutdown 2: Trip and Stop 3: Trip	0	Alarm type can be selected; when alarm is active, it will start alarm handle according to the selected alarm type.
		Type: Definite Time; IDMT	Definite Time	If Definite Time is set, then do alarm delay handle by setting fixed delay time; If IDMT is set, then do alarm delay handle



No.	Items	Parameters Range	Defaults	Description
				by setting multiplier.
		(0~3600)s	10	After Definite Time is active, realize alarm delay by setting this value.
		(1~36)	36	After IDMT is active, realize alarm delay by setting this multiplier.
5	Reverse Power	0: Disable 1: Enable	0	Start to detect alarms when it is enabled; not detect alarms when disabled;
		(0~200)%	10	Set value is percentage of AC Gen rated power; when power is negative and above this value, start alarm handle.
		(0~200)%	5	Set value is percentage of AC Gen rated power; when alarm is active, power is negative and below return value, alarm can be cleared automatically.
		(0~3600)s	5	Alarm starts when power reaches alarm value and this delay time is expired.
6	Reverse Power Action	(0~3)	0	0: Warning; 1: Shutdown; 3: Trip and Stop; 4: Trip
7	Over Power	0: Disable 1: Enable	0	Start to detect alarms when it is enabled; not detect alarms when disabled;
		(0~200)%	110	Set value is percentage of AC Gen rated power; when power is negative and above this value, start alarm handle.
		(0~200)%	105	Set value is percentage of AC Gen rated power; when alarm is active, power is positive and below return value, alarm can be cleared automatically.
		(0~3600)s	5	Alarm starts when power reaches alarm value and this delay time is expired.
8	Over Power Action	(0~3)	0	0: Warning; 1: Shutdown; 3: Trip and Stop; 4: Trip
Breaker				
1	Close Time	(0~20.0)s	5.0	Pulse width of generator switch on. When it is 0, means output constantly.
2	Open Time	(0~20.0)s	3.0	Pulse width of generator switch off.
3	Check Time	(0~20.0)s	5.0	Time of detecting switch auxiliary contacts after ATS breaker transferred.
4	Open Check	(0~1)	0	0: Disable 1: Enable
5	Transfer Failure Warn	(0~1)	0	0: Disable 1: Enable
Module				
1	Power on Mode	(0~2)	0	0: Stop mode 1: Manual mode 2: Auto mode
2	Module Address	(1~254)	1	Controller's address during remote



No.	Items	Parameters Range	Defaults	Description
				sensing.
4	Language	(0~2)	0	0: Chinese 1: English 2: Other
5	Password	(0~65535)	00318	For entering parameters setting.
6	Time and Date			Current time and date can be set by users.
7	IP Set	(0~1)	1	0: Disable 1: Enable All the settings about Ethernet (such as IP address and subnet mask) will active after the next time power on.
Scheduling and Maintenance Setting				
1	Scheduled Run	(0~1)	0	0: Disable; 1: Enable
2	Maintenance	(0~1)	0	0: Disable; 1: Enable
3	Scheduled Not Run	(0~1)	0	0: Disable; 1: Enable
Analog Sensor				
Temperature Sensor				
1	Curve Type	(0~15)	9	SGD. See Table 16.
2	Open Circuit Action	(0~2)	0	0: Warning; 1: Shutdown; 2: No action
3	High Temp. Shutdown	0: Disable 1: Enable	1	Start to detect alarms when it is enabled; not detect alarms when disabled.
		(0~300)°C	98	When external temp. sensor value is above this value, temp. high shutdown alarm is issued. It is detected only after Safety On Delay is over.
		(0~3600)s	3	Alarm starts when temp. reaches alarm value and this delay time is expired.
4	High Temp. Warning	0: Disable 1: Enable	1	Start to detect alarms when it is enabled; not detect alarms when disabled.
		(0~300)°C	95	When external temp. sensor value is above this value, temp. high warning alarm is issued. It is detected only after Safety On Delay is over.
		(0~300)°C	93	When temp. high warning is active, temp is below return value, alarm can be cleared automatically.
		(0~3600)s	5	Alarm starts when temp. reaches alarm value and this delay time is expired.
5	Low Temp. Warning	0: Disable 1: Enable	0	Start to detect alarms when it is enabled; not detect alarms when disabled.
		(0~300)°C	70	When external temp. sensor value is below this value, temp. low warning alarm is issued. It is detected only after Safety On Delay is over.



No.	Items	Parameters Range	Defaults	Description
		(0~300)°C	75	When temp. low warning is active, temp. is above return value, alarm can be cleared automatically.
		(0~3600)s	5	Alarm starts when temp. reaches alarm value and this delay time is expired.
6	Custom Curve			Users can configure it according to sensor's performance.
Oil Pressure Sensor				
1	Curve Type	(0~15)	9	SGD. See Table 16.
2	Open Circuit Action	(0~2)	0	0: Warning 1: Shutdown 2: No action
3	Low OP Shutdown	0: Disable 1: Enable	1	Start to detect alarms when it is enabled; not detect alarms when disabled.
		(0~1000)kPa	103	When external oil pressure value is below this value, oil pressure low shutdown alarm is issued. It is only detected after Safety On Delay is over.
		(0~3600)s	3	Alarm starts when oil pressure reaches alarm value and this delay time is expired.
4	Low OP Warning	0: Disable 1: Enable	1	Start to detect alarms when it is enabled; not detect alarms when disabled.
		(0~1000)kPa	124	When external oil pressure value is below this value, oil pressure low warning alarm is issued. It is only detected after Safety On Delay is over.
		(0~1000)kPa	138	When oil pressure low alarm is active, oil pressure is above return value, alarm can be cleared automatically.
		(0~3600)s	5	Alarm starts when oil pressure reaches alarm value and this delay time is expired.
5	Custom Curve			Users can configure it according to sensor's performance.
Level Sensor				
1	Curve Type	(0~15)	5	SGH. See Table 16.
2	Open Circuit Action	(0~2)	0	0: Warning; 1: Shutdown; 2: No action
3	Low Level Warning	0: Disable 1: Enable	1	Start to detect alarms when it is enabled; not detect alarms when disabled.
		(0~300)%	10	When external level sensor value is below this value, low warning is issued. It is detected always.
		(0~300)%	15	When level low alarm is active, level is above return value, alarm can be cleared automatically.
		(0~3600)s	5	Alarm starts when level reaches alarm



No.	Items	Parameters Range	Defaults	Description
				value and this delay time is expired.
4	Custom Curve			Users can configure it according to sensor's performance.
Flexible Sensor 1				
1	Flexible Sensor 1 Setting	(0~3)	0	0: Not Used 1: Temp. Sensor 2: Pressure Sensor 3: Level Sensor
Flexible Sensor 2				
1	Flexible Sensor 2 Setting	(0~3)	0	0: Not Used 1: Temp. Sensor 2: Pressure Sensor 3: Level Sensor
Digital Inputs				
Digital Input Port 1				
1	Contents Setting	(0~55)	28	Remote start On Load. See Table 15
2	Active Type	(0~1)	0	0: Closed to Activate 1: Open to Activate
Digital Input Port 2				
1	Contents Setting	(0~55)	26	High Temperature Shutdown See Table 15
2	Active Type	(0~1)	0	0: Closed to Activate 1: Open to Activate
Digital Input Port 3				
1	Contents Setting	(0~55)	27	Low Oil Pressure Shutdown See Table 15
2	Active Type	(0~1)	0	0: Closed to Activate 1: Open to Activate
Digital Input Port 4				
1	Contents Setting	(0~55)	0	User Configured. See Table 15
2	Active Type	(0~1)	0	0: Closed to Activate 1: Open to Activate
3	Arming	(0~3)	2	0: From safety on 1: From Crank 2: Always 3: Never
4	Active Actions	(0~4)	0	0: Warning; 1: Shutdown; 2: Trip and stop 3: Trip 4: Indication
5	Active Delay	(0~20.0)s	2.0	Time from detecting active to confirm
6	Description			LCD display detailed contents when the input is active.
Digital Input Port 5				
1	Contents Setting	(0~55)	0	User Configured. See Table 15
2	Active Type	(0~1)	0	0: Closed to Activate 1: Open to Activate
3	Arming	(0~3)	2	0: From safety on 1: From Crank



No.	Items	Parameters Range	Defaults	Description
				2: Always 3: Never
4	Active Actions	(0~4)	1	0: Warning; 1: Shutdown; 2: Trip and stop 3: Trip 4: Indication
5	Active Delay	(0~20.0)s	2.0	Time from detecting active to confirm
6	Description			LCD display detailed contents when the input is active.
Digital Input Port 6				
1	Contents Setting	(0~55)	0	User defined. See Table 15
2	Active Type	(0~1)	0	0: Closed to Activate 1: Open to Activate
3	Arming	(0~3)	2	0: From safety on 1: From Crank 2: Always 3: Never
4	Active Actions	(0~4)	2	0: Warning; 1: Shutdown; 2: Trip and stop 3: Trip 4: Indication
5	Active Delay	(0~20.0)s	2.0	Time from detecting active to confirm
6	Description			LCD display detailed contents when the input is active.
Digital Input Port 7				
1	Contents Setting	(0~55)	5	Lamp Test. See Table 15
2	Active Type	(0~1)	0	0: Closed to Activate 1: Open to Activate
Digital Input Port 8				
1	Contents Setting	(0~55)	0	User Configured. See Table 15
2	Active Type	(0~1)	0	0: Closed to Activate 1: Open to Activate
3	Arming	(0~3)	0	0: From safety on 1: From Crank 2: Always 3: Never
4	Active Actions	(0~4)	0	0: Warning; 1: Shutdown; 2: Trip and stop 3: Trip 4: Indication
5	Active Delay	(0~20.0)s	2.0	Time from detecting active to confirm
6	Description			LCD display detailed contents when the input is active.
Relay Outputs				
Relay Output Port 1				
1	Contents Setting	(0~299)	1	Custom Period 1. See Table 14.
2	Active Type	(0~1)	0	0: Output(N/O) 1: Output(N/C)
Relay Output Port 2				
1	Contents Setting	(0~299)	35	Idle Control. See Table 14.
2	Active Type	(0~1)	0	0: Output(N/O) 1: Output(N/C)
Relay Output Port 3				
1	Contents Setting	(0~299)	29	Close Generator. See Table 14.
2	Active Type	(0~1)	0	0: Output(N/O) 1: Output(N/C)
Relay Output Port 4				
1	Contents Setting	(0~299)	31	Reserved. See Table 14.

No.	Items	Parameters Range	Defaults	Description
2	Active Type	(0~1)	0	0: Output(N/O) 1: Output(N/C)
Relay Output Port 5				
1	Contents Setting	(0~299)	38	Energize to Stop. See Table 14.
2	Active Type	(0~1)	0	0: Output(N/O) 1: Output(N/C)
Relay Output Port 6				
1	Contents Setting	(0~299)	48	Common Alarm. See Table 14.
2	Active Type	(0~1)	0	0: Output(N/O) 1: Output(N/C)

8.2 ENABLE DEFINITION CONTENTS OF DIGITAL OUTPUT PORTS

8.2.1 DEFINED CONTENTS OF DIGITAL OUTPUT PORTS

Table 14 - Defined Contents of Digital Output Ports

No.	Type	Description	
0	Not Used		
1	Custom Period 1	For function description details please see the following.	
2	Custom Period 2		
3	Custom Period 3		
4	Custom Period 4		
5	Custom Period 5		
6	Custom Period 6		
7	Custom Combined 1		
8	Custom Combined 2		
9	Custom Combined 3		
10	Custom Combined 4		
11	Custom Combined 5		
12	Custom Combined 6		
13	Oil Pre-heat Output		
14	Reserved		
15	Reserved		
16	Reserved		
17	Air Flap Control	Act at over speed shutdown and emergency stop; Engine air inlet can be closed.	
18	Audible Alarm	Act at warning, shutdown, electric trip; Annunciator can be connected externally; When flexible input "Alarm Mute" is active, it can be prohibited to output.	
19	Louver Control	Act at generator start, disconnect after genset complete stop.	
20	Fuel Pump Control	It is controlled by the upper and lower limits of level sensor fuel pump control.	
21	Heater Control	It is controlled by the upper and lower limits of temp. sensor heating control.	
22	Cooler Control	It is controlled by the upper and lower limits of temp. sensor cooling control.	
23	Fuel Pre-supply	Act in the period from crank to safety on time.	



No.	Type	Description
24	Generator Excitation	Output in the crank process; output for 2s again if Gen frequency is lost in high speed period.
25	Oil Pre-lubrication	Act in the period from pre-heating to safety on time.
26	Remote Control	This port is controlled by communication (PC).
27	Reserved	
28	Reserved	
29	Close Generator	Control generator breaker to take load.
30	Open Breaker	Control generator breaker to take off load.
31	Reserved	
32	Reserved	
33	Starter Relay	
34	Fuel Relay	Act at generator start, disconnect at waiting to stop.
35	Idle Control	Used for gensets with idle speed control; Pull in before crank, disconnect at entering warming up period; Pull in at stop idle process, and disconnect at genset complete stop.
36	Speed Raise Relay	Act in the period of warming up.
37	Speed Drop Relay	Act in the period of stop idle and wait to stop running time.
38	Energize to Stop	Used for engines with ETS electromagnet. Close when stop idle is over and open when pre-set "ETS delay" is over.
39	Speed Drop Pulse	Act for 0.1s when controller enters into stop idle, used to control part of ECU dropping to idle speed.
40	ECU Stop	Used for ECU engine and control its stop.
41	ECU Power Supply	Used for ECU engine and control its power.
42	Speed Raise Pulse	Act for 0.1s when controller enters into warming up delay; used to control part of ECU raising to normal speed.
43	Crank Success	Close when a successful start signal is detected.
44	Generator OK	Act when generating is normal.
45	Generator Available	Act in period of generator ok to high-speed cooling.
46	Reserved	
47	Reserved	
48	Common Alarm	Act at genset common warning, common shutdown, common trips alarm occur.
49	Common Trip and Stop	Act when common trip and stop alarm occurs.
50	Common Shutdown	Act when common shutdown alarm occurs.
51	Common Trip	Act when common trips alarm occurs.
52	Common Warning	Act when common warning alarm occurs.
53	Reserved	
54	Battery Over Voltage	Act when battery's over voltage warning alarm occurs.
55	Battery Under Voltage	Act when battery's low voltage warning alarm occurs.
56	Charge Alternator Failure	Act when charge failure warning alarm occurs.
57	Reserved	
58	Reserved	
59	Reserved	



No.	Type	Description
60	ECU Warning	Indicate ECU sends a warning signal.
61	ECU Shutdown	Indicate ECU sends a shutdown signal.
62	ECU Communication Failure	Indicate controller not communicate with ECU.
63	Reserved	
64	Reserved	
65	Reserved	
66	Reserved	
67	Reserved	
68	Reserved	
69	Digital Input 1 Active	Act when input port 1 is active
70	Digital Input 2 Active	Act when input port 2 is active
71	Digital Input 3 Active	Act when input port 3 is active
72	Digital Input 4 Active	Act when input port 4 is active
73	Digital Input 5 Active	Act when input port 5 is active
74	Digital Input 6 Active	Act when input port 6 is active
75	Digital Input 7 Active	Act when input port 7 is active
76	Digital Input 8 Active	Act when input port 8 is active
77~80	Reserved	
81~96	Expand Digital Input 1-16	Act when expand input port is active.
97~98	Reserved	
99	Emergency Stop	Act when emergency stop alarm occurs.
100	Fail to Start	Act when failed start alarm occurs.
101	Fail to Stop	Act when failed stop alarm occurs.
102	Under Speed Warn	Act when under speed alarm occurs.
103	Under Speed Shutdown	Act when under speed shuts down.
104	Over Speed Warning	Act when over speed warns.
105	Over Speed Shutdown	Act when over speed shutdown alarm occurs.
106	Reserved	
107	Reserved	
108	Reserved	
109	AC Over Freq Warn	Act when generator over frequency warning occurs.
110	AC Over Freq Shutdown	Act when generator over frequency shutdown alarm occurs.
111	AC Over Voltage Warn	Act when generator over voltage warning occurs.
112	AC Over Voltage Shutdown	Act when generator over voltage shutdown occurs.
113	AC Under Freq. Warn	Act when generator low frequency warning occurs.
114	AC Under Freq. Shutdown	Act when generator low frequency shutdown occurs.
115	AC Under Voltage Warn	Act when generator low voltage warning occurs.
116	AC Under Voltage Shutdown	Act when generator low voltage shutdown occurs.
117	AC Loss of Phase	Act when generator loss phase.
118	AC Reverse Phase Seq.	Act when generator reverse phase.
119	Reserved	
120	AC Over Power	Act when controller detects AC generator has over power.
121	Reserved	



No.	Type	Description
122	AC Reverse Power	Act when controller detects AC generator has reverse power.
123	AC Over Current Alarm	Act when controller detects AC generator over current.
124	Reserved	
125	DC Over Volt Warn	Act when controller detects DC generator over voltage.
126	DC Over Volt Shutdown	Act when controller detects DC generator over voltage.
127	DC Over Current Alarm	Act when controller detects DC generator over current.
128	DC Over Power Alarm	Act when controller detects DC generator over power.
129~138	Reserved	
139	High Temperature Warn	Act when hi-temperature warning occurs.
140	Low Temperature Warn	Act when low temperature warning occurs.
141	High Temperature Shutdown	Act when hi-temperature shutdown alarm occurs.
142	Reserved	
143	Low Oil Pressure Warn	Act when low oil pressure warning occurs.
144	Low Oil Pressure Shutdown	Act when low oil pressure shutdown occurs.
145	Oil Pressure Open Circuit	Act when oil pressure sensor is open circuit.
146	Reserved	
147	Low Fuel Level	Act when controller has low fuel level alarm.
148	Reserved	
149	Reserved	
150	Flexible Sensor 1 High Warn	
151	Flexible Sensor 1 Low Warn	
152	Flexible Sensor 1 High Shut	
153	Flexible Sensor 1 Low Shut	
154	Flexible Sensor 2 High Warn	
155	Flexible Sensor 2 Low Warn	
156	Flexible Sensor 2 High Shut	
157	Flexible Sensor 2 Low Shut	
158~161	Reserved	
162	Exp1 Ch15 High Shut	
163	Exp1 Ch15 High Warn	
164	Exp1 Ch15 Low Shut	
165	Exp1 Ch15 Low Warn	
166	Exp1 Ch16 High Shut	
167	Exp1 Ch16 High Warn	
168	Exp1 Ch16 Low Shut	
169	Exp1 Ch16 Low Warn	
170	Exp1 Ch17 High Shut	
171	Exp1 Ch17 High Warn	
172	Exp1 Ch17 Low Shut	
173	Exp1 Ch17 Low Warn	
174	Exp1 Ch18 High Shut	
175	Exp1 Ch18 High Warn	



No.	Type	Description
176	Exp1 Ch18 Low Shut	
177	Exp1 Ch18 Low Warn	
178	Exp1 Ch19 High Shut	
179	Exp1 Ch19 High Warn	
180	Exp1 Ch19 Low Shut	
181	Exp1 Ch19 Low Warn	
182	Exp1 Ch20 High Shut	
183	Exp1 Ch20 High Warn	
184	Exp1 Ch20 Low Shut	
185	Exp1 Ch20 Low Warn	
186	Exp1 Ch21 High Shut	
187	Exp1 Ch21 High Warn	
188	Exp1 Ch21 Low Shut	
189	Exp1 Ch21 Low Warn	
190	Exp1 Ch22 High Shut	
191	Exp1 Ch22 High Warn	
192	Exp1 Ch22 Low Shut	
193	Exp1 Ch22 Low Warn	
194	Exp1 Ch23 High Shut	
195	Exp1 Ch23 High Warn	
196	Exp1 Ch23 Low Shut	
197	Exp1 Ch23 Low Warn	
198	Exp1 Ch24 High Shut	
199	Exp1 Ch24 High Warn	
200	Exp1 Ch24 Low Shut	
201	Exp1 Ch24 Low Warn	
202~229	Reserved	
230	At Stop Mode	Act when system is in Stop mode.
231	At Manual Mode	Act when system is in Manual mode.
232	Reserved	
233	At Auto Mode	Act when system is in Auto mode.
234	Generator Load Indication	
235	Reserved	
236~239	Reserved	
240~279	PLC Flag 1-40	Act when PLC flag is 1.
280~299	Reserved	

8.2.2 CUSTOM PERIOD OUTPUT

Defined Period output is composed by 2 parts, **period output S1** and **condition output S2**.



While **S1** and **S2** are **TRUE** synchronously, **OUTPUT**;

While **S1** or **S2** is **FALSE**, **NOT OUTPUT**.

Period output S1, can set generator's one or more period output freely, can set the delayed time and output time after enter into period.

Condition output S2; can set as any conditions in output ports.

NOTE: when delay time and output time both are 0 in period output S1, it is TRUE in this period.

Example,

Output period: start

Delay output time: 2s

Output time: 3s

Condition output contents: input port 1 is active

Close when condition output active/inactive: close when active (disconnect when inactive);

Output port 1 active, after enter "starts time" and delay 2s, this defined period output is outputting, after 3s, stop outputting;

Output port 1 inactive, defined output period is not outputting.

8.2.3 CUSTOM COMBINED OUTPUT

Defined combination output is composed by 3 parts, OR condition output S1, S2, AND condition output S3.

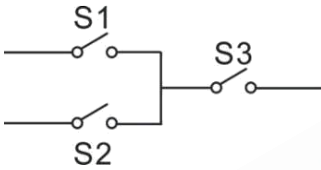

S1 or **S2** is **TRUE**, and **S3** is **TRUE**, defined combination output is outputting;

S1 and **S2** are **FALSE**, or **S3** is **FALSE**, defined combination output is not outputting.

NOTE: S1, S2, S3 can be set as any contents except for "defined combination output" in the output setting.

NOTE: 3 parts of defined combination output (S1, S2, S3) **couldn't include or recursively include themselves**.

Example,

Contents of "or" condition output S1: input port 1 is active;

Close when "or" condition output S1 is active /inactive: close when active (disconnect when inactive);

Contents of "or" condition output S2, input port 2 is active;

Close when "or" condition output S2 is active /inactive: close when active (disconnect when inactive);

Contents of "and" condition output S3: input port 3 is active;

Close when "and" condition output S3 is active /inactive: close when active (disconnect when inactive);

When input port 1 active or input port 2 active, if input port 3 is active, defined combination output is outputting; If input port 3 inactive, defined combination output is not outputting;

When input port 1 inactive and input port 2 inactive, whatever input port 3 is active or not, defined combination output is not outputting.

8.3 DEFINED CONTENTS OF DIGITAL INPUT PORTS (ALL GND(B-) CONNECTED ACTIVE)

Table 15 - Defined Contents of Digital Input Ports

No.	Type	Description
0	Users Configured	Including following functions, Indication: indicate only, not warning or shutdown. Warning: warn only, not shutdown. Shutdown: alarm and shutdown immediately Trip and stop: alarm, generator unloads and shutdown after hi-speed cooling Trip: alarm, generator unloads but not shutdown. Never: input inactive. Always: input is active all the time. From crank: detecting as soon as start. From safety on: detecting after safety on run delay.
1	Reserved	
2	Alarm Mute	Can prohibit "Audible Alarm" output when input is active.
3	Reset Alarm	Can reset shutdown alarm and trip alarm when input is active.
4	60Hz Active	Use for CANBUS engine and it is 60Hz when input is active.
5	Lamp Test	All LED indicators are illuminated when input is active.
6	Panel Lock	All keys in panel are inactive except navigation and return keys and there is  on the right of first row in LCD when input is active.
7	War Mode	All shutdown alarms except alarms of emergency stop and over speed shutdown cannot stop the engine in the war mode.
8	Idle Mode	Under voltage/frequency/speed protection is inactive.
9	Auto Stop Inhibit	In Auto mode, during generator normal running, when input is active, inhibit generator shutdown automatically.
10	Auto Start Inhibit	In Auto mode, inhibit generator start automatically when input is active.
11	Scheduled Run Inhibit	In Auto mode, inhibit scheduled run genset when input is active.
12	Reserved	
13	Generator Closed Status	Connect generator loading switch's Aux. Point.
14	Generator Load Inhibit	Prohibit genset switch on when input is active.
15	Reserved	
16	Reserved	
17	Auto Mode Lock	When input is active, controller enters into auto mode; mode selection keys are inactive.
18	Auto Mode Inhibit	When input is active, controller won't work under auto mode. Auto mode key and simulate auto key input does not work.



No.	Type	Description
19	Reserved	
20	Reserved	
21	Alarm Stop Inhibit	All shutdown alarms are prohibited except emergency stop.(Means battle mode or override mode)
22	Instrument Mode	All outputs are prohibited in this mode.
23	Reserved	
24	Reset Maintenance Time	Controller will set maintenance time and date as default when input is active.
25	Reserved	
26	High Temperature Shutdown	Connected sensor digital input.
27	Low Oil Pressure Shutdown	Connected sensor digital input.
28	Remote Start On Load	In Auto mode, when input is active, genset can be started automatically and take load after genset normal running; when input is inactive, genset will stop automatically.
29	Remote Start Off Load	In Auto mode, when input is active, genset can be started automatically and NOT take load after genset normal running; when input is inactive, genset will stop automatically.
30	Manual Start Input	In Manual mode, when input active, genset will start automatically; when input inactive, genset will stop automatically.
31	Reserved	
32	Reserved	
33	Simulate Stop Key	An external button can be connected and pressed as simulate panel.
34	Simulate Manual Key	
35	Reserved	
36	Simulate Auto Key	An external button can be connected and pressed as simulate panel.
37	Simulate Start Key	
38	Simulate Gen Close Key	
39	Simulate Gen Open Key	
40	Reserved	
41	Reserved	
42	Reserved	
43	Reserved	
44	Reserved	
45	Reserved	
46	Reserved	
47	Alt. Config. 1 Active	When input port is active, users can set different parameters to make it easy to select current configuration via input port.
48	Alt. Config. 2 Active	
49	Alt. Config. 3 Active	
50~55	Reserved	

8.4 SELECTION OF SENSORS

Table 16 - Sensors Selection

No.		Description	Remark
1	Temperature Sensor	0 Not Used 1 User Configured (Resistance) 2 User Config. (4-20)mA Curve 3 User Config.(0-5)V Curve 4 VDO 5 CURTIS 6 VOLVO-EC 7 DATCON 8 SGX 9 SGD 10 SGH 11 PT100 12 SUSUKI 13 PRO 14~15 Reserved	Defined resistance's range is (0~6)KΩ, default is SGD sensor.
2	Pressure Sensor	0 Not Used 1 User Configured (Resistance) 2 User Config. (4-20)mA Curve 3 User Config.(0-5)V Curve 4 VDO 10Bar 5 CURTIS 6 VOLVO-EC 7 DATCON 10Bar 8 SGX 9 SGD 10 SGH 11 VDO 5Bar 12 DATCON 5Bar 13 DATCON 7Bar 14 SUSUKI 15 PRO	Defined resistance's range is (0~6)KΩ, default is SGD sensor.
3	Fuel Level Sensor	0 Not used 1 User Configured (Resistance) 2 User Config. (4-20)mA Curve 3 User Config.(0-5)V Voltage Curve 4 SGD 5 SGH 6~15 Reserved	Defined resistance's range is (0~6)KΩ, default is SGH sensor.

NOTE: Above curve types are suitable for two flexible sensors, and the No.2 and No.3 items of fixed temperature/oil pressure/level sensor are configured as reserved.

8.5 SELECTION OF CRANK DISCONNECT CONDITIONS

Table 17 - Crank Disconnect Conditions Selection

No.	Setting description
0	Gen frequency
1	Speed
2	Speed + Gen frequency
3	Oil pressure
4	Oil pressure + Gen frequency
5	Oil pressure + Speed
6	Oil pressure + Speed + Gen frequency

- a) There are three kinds of separation conditions for starter and engine, speed, frequency, and oil pressure, all of which can be used separately. But it is suggested to use oil pressure, speed and frequency together cooperatively, in order to make starter motor and engine separate as soon as possible.
- b) Speed sensor is the magnetic equipment installed on engine body to detect flywheel teeth number.
- c) When speed is selected, please ensure engine flywheel teeth number is the same with the pre-set, otherwise over speed shutdown or under speed shutdown may occur.
- d) If speed sensor is not installed for genset, please don't select related items, otherwise failed to crank or loss of speed signal shutdown may occur.
- e) if oil pressure sensor is not installed for genset, please don't select related items.
- f) if Gen frequency is not selected for conditions, then controller doesn't collect and display related power of Gens (can be used for pump unit); if speed is not selected, then the speed displayed on controller is calculated by Gen signals.

9 PARAMETERS SETTING

⚠CAUTION: Please change the controller parameters when generator is in standby mode only (e. g. Crank disconnect conditions selection, configurable input, configurable output, various delay), otherwise, shutdown or other abnormal conditions may happen.

△NOTE:

- 1) Maximum set value must be over minimum set value in case that the condition of too high as well as too low will happen.
- 2) When warning alarms are set, please set return value correctly, otherwise alarm may not work normally. At setting over high warnings, return value shall be less than set value; At setting over low warnings, return value shall be more than set value.
- 3) At successful crank, try to set Gen frequency as low as possible, so that starter can be separated quickly when genset started.
- 4) Flexible input ports cannot be set to the same items, otherwise incorrect functions may occur; flexible output ports can be set to the same items.

SmartGen

10 SENSORS SETTING

- At reselecting sensors, the sensor curve will be transferred into the standard value. For example, if temperature sensor is SGX (120°C resistor type), its sensor curve is SGX (120°C resistor type); if select the SGD (120°C resistor type), the temperature sensor curve is SGD curve.
- When there is difference between standard sensor curves and used sensor, user can adjust it in “curve type”.
- When input the sensor curve, X value (resistor) must be input from small to large, otherwise, mistake occurs.
- If select sensor type as “None”, sensor curve is not working.
- If corresponding sensor has alarm switch only, user must set this sensor as “None”, otherwise, maybe there is shutdown or warning.
- The headmost or backmost values in the vertical coordinates can be set as same as below,

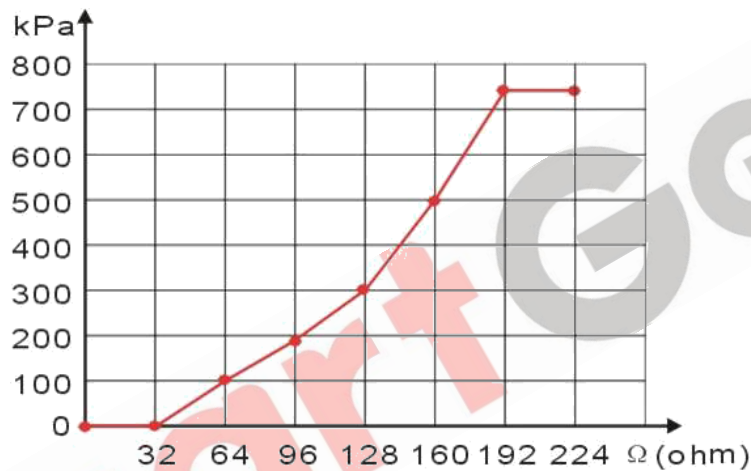

Fig. 3 - Sensor Curve Setting

Table 18 - Normal Pressure Unit Conversion Form

Items	N/m ² pa	kgf/cm ²	bar	psi
1Pa	1	1.02x10 ⁻⁵	1x10 ⁻⁵	1.45x10 ⁻⁴
1kgf/cm ²	9.8x10 ⁴	1	0.98	14.2
1bar	1x10 ⁵	1.02	1	14.5
1psi	6.89x10 ³	7.03x10 ⁻²	6.89x10 ⁻²	1

11 COMMISSIONING

Before system formal running, it is suggested to do following checks.

- Ensure all the connections are correct and wires diameter is suitable.
- Ensure that the controller DC power has fuse, controller's positive and negative connected to start battery are correct.
- Emergency stop input is connected to positive of starter battery via the N/C point of emergency button and the fuse.
- Take proper action to prevent engine to crank disconnect (e. g. Remove the connection wire of fuel valve). If checking is OK, make the starter battery power on; choose manual mode and controller will execute routine.
- Set controller under manual mode, press "start" button, genset will start. If start fails after pre-set start attempts, controller will send signal of Start Failure; then press "stop" to reset controller.
- Recover the action of stopping engine start (e. g. Connect wire of fuel valve), press start button again, genset will start. If everything goes well, genset will go to normal running after idle running (if idle run is set). During this time, please observe engine's running situations, AC generator's voltage and frequency and DC generator voltage. If something abnormal occurs, stop genset running and check all wires connection according to this manual.
- If there is any other question, please contact SmartGen's service.

SmartGen

12 TYPICAL APPLICATION

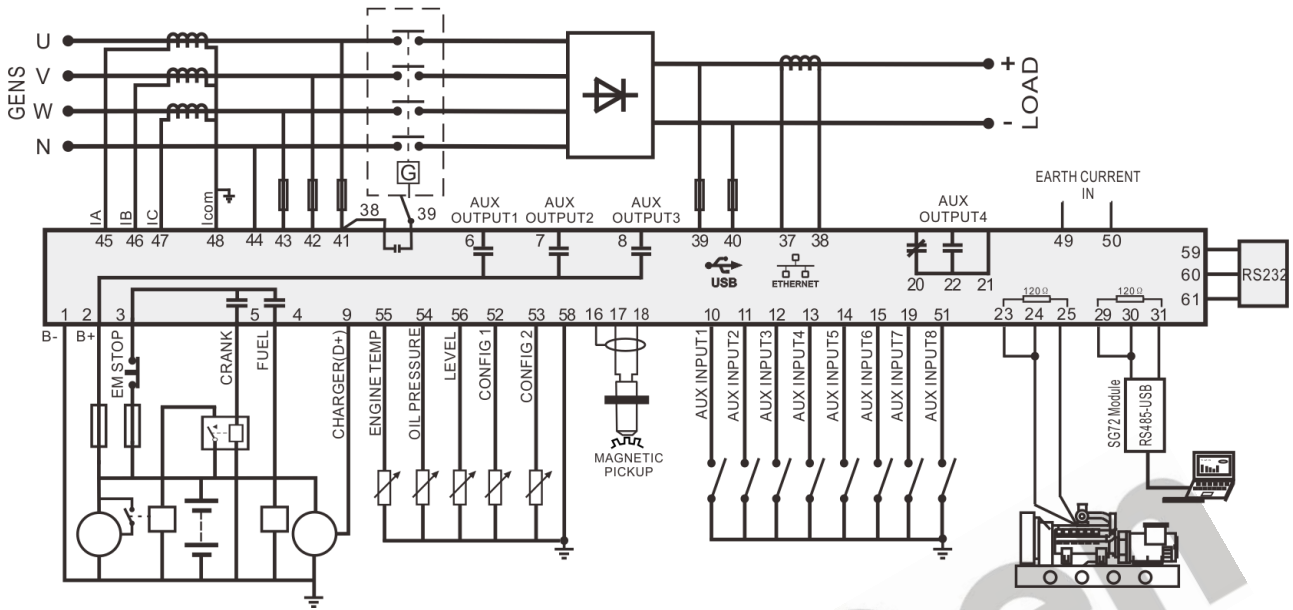

Fig. 4 - HGM810DC-1 Typical Application Diagram

NOTE: B+ fuse: minimum 2A, and maximum 20A. Emergency stop fuse: maximum 32A. Customers should select appropriate fuse based on the local situation.

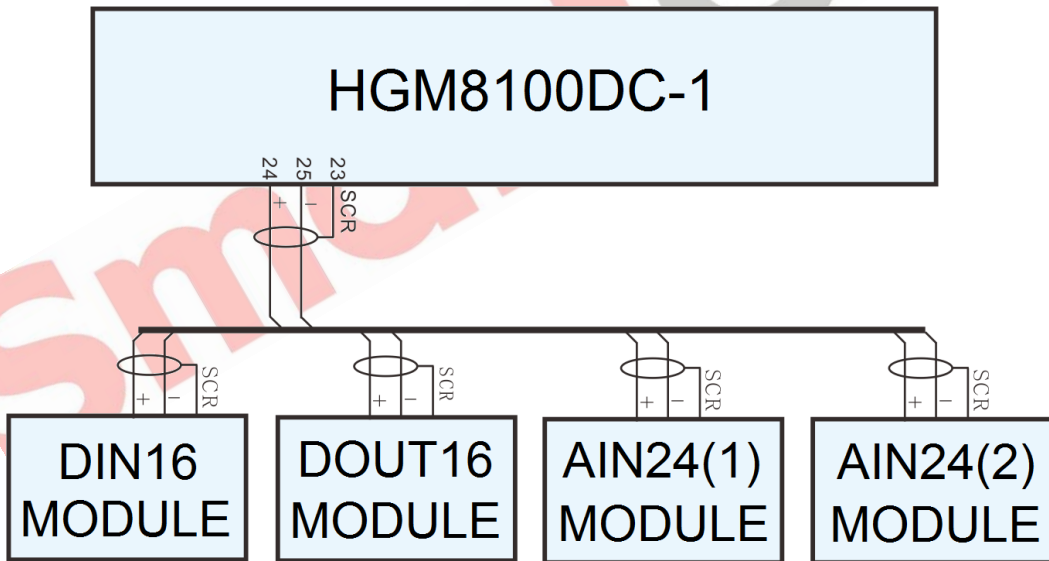

Fig. 5 - HGM810DC-1 Expand Module Typical Application Diagram

13 INSTALLATION

13.1 OVERALL DIMENSION

Controller is panel built-in design; it is fixed by clips when installed. The controller's overall and cutout dimensions are as below.

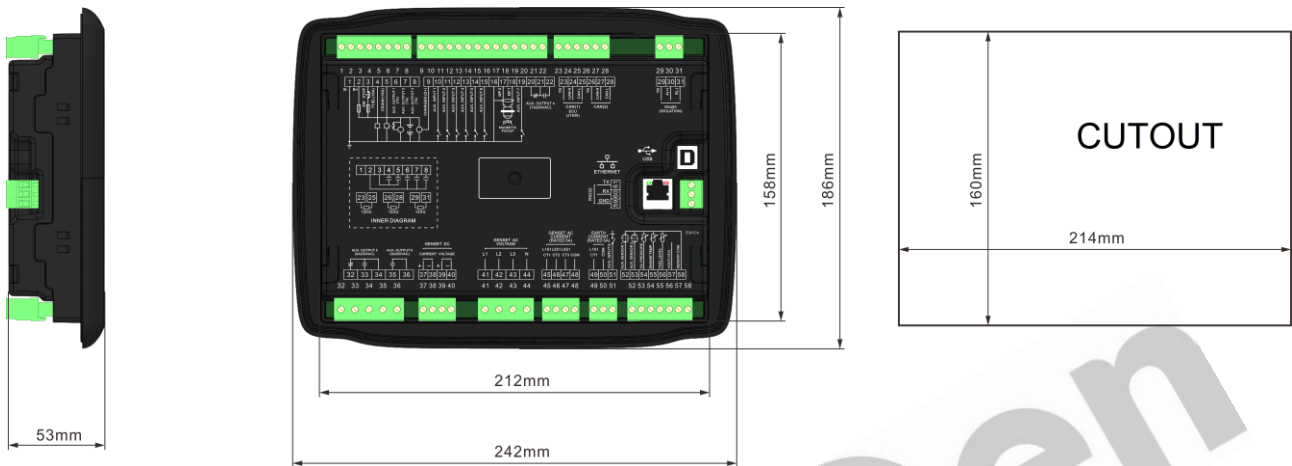

Fig.6 - Overall and Cutout Dimensions

13.2 BATTERY VOLTAGE INPUT

HGM8110DC-1 controller can suit for wide range of battery voltage DC(8~35)V. Negative of battery must be connected with the engine shell. Diameter of wire that connects from power supply B+ and B- to battery positive and negative must be over 2.5mm². If floating charger is configured, please firstly connect output wires of charger to battery's positive and negative directly, then, connect wires from battery's positive and negative to controller's positive and negative input terminals in order to prevent charger disturbing the controller's normal working.

13.3 SPEED SENSOR INPUT

Speed sensor is the magnetic equipment installed in engine body to detect flywheel teeth. Its connection wires to controller should apply 2-core shielding line. The shielding layer should connect to No. 16 terminal in controller while another side is hanging in air. The other two signal wires are connected to No.17 and No.18 terminals of controller. The output voltage of speed sensor should be within AC(1~24)V (RMS) at full speed. AC12V is recommended (at rated speed). When installs the speed sensor, let the sensor spun to contacting flywheel first, then, port out 1/3 lap, and lock the nuts of sensor at last.

13.4 OUTPUT AND EXPAND RELAYS

CAUTION: All outputs of controller are relay contact output type. If it needs to expand the relays, please add freewheel diode to both ends of expand relay's coils (when coils of relay have DC current) or, increase resistance-capacitance return circuit (when coils of relay have AC current), in order to prevent disturbance to controller or other equipment.

13.5 AC INPUT

Current input of controller must be connected to outside current transformer. And the current transformer's secondary side current must be 5A. At the same time, the phases of current transformer and input voltage must be correct. Otherwise, the collected current and active power may not be correct.

NOTE: ICOM terminal must be connected to negative pole of controller power.

WARNING! When there is load current, transformer's secondary side is prohibited to open circuit.

13.6 WITHSTAND VOLTAGE TEST

CAUTION! When controller has been installed in control window, if it needs voltage withstand test, please disconnect controller's all terminal connections, in order to prevent high voltage entering controller and damaging it.

SmartGen

14 CONNECTIONS OF CONTROLLER WITH J1939 ENGINE

14.1 CUMMINS ISB/ISBE

Table 19 - Connector B

Terminals of controller	Connector B	Remark
Fuel relay output	39	
Starter relay output	-	Connect with starter coil directly.
Auxiliary output 1	Expand 30A relay, battery voltage of 01, 07, 12, 13 is supplied by relay.	ECU power; Set auxiliary output 1 as "ECU power".

Table 20 - 9 Pins Connector

Terminals of controller	9 pins connector	Remark
CAN GND	SAE J1939 shield	CAN communication shielding line (connect with ECU terminal only).
CAN(H)	SAE J1939 signal	Impedance 120Ω connecting line is recommended.
CAN(L)	SAE J1939 return	Impedance 120Ω connecting line is recommended.

Engine type: Cummins ISB.

14.2 CUMMINS QSL9

Suitable for CM850 engine control module.

Table 21 - 50-Pin Connector

Terminals of controller	50 pins connector	Remark
Fuel relay output	39	
Starter relay output	-	Connect to starter coil directly.

Table 22 - 9-Pin Connector

Terminals of controller	9 pins connector	Remark
CAN GND	SAE J1939 shield-E	CAN communication shielding line (connect with ECU terminal only).
CAN(H)	SAE J1939 signal-C	Impedance 120Ω connecting line is recommended.
CAN(L)	SAE J1939 return-D	Impedance 120Ω connecting line is recommended.

Engine type: Cummins-CM850.

14.3 CUMMINS QSM11 (IMPORT)

It is suitable for CM570 engine control module. Engine type is QSM11 G1, QSM11 G2.

Table 23 - C1 Pin Connector

Terminals of controller	C1 connector	Remark
Fuel relay output	5&8	Externally extend relay, when fuel is outputting, connect Terminal 5 and Terminal 8 of C1 connector.
Starter relay output	-	Connect to starter coil directly.

Table 24 - 3-Pin Data Link Connector

Terminals of controller	3 pins data link connector	Remark
CAN GND	C	CAN communication shielding line (connect with ECU terminal only).
CAN(H)	A	Using impedance 120Ω connecting line.
CAN(L)	B	Using impedance 120Ω connecting line.

Engine type: Cummins ISB.

14.4 CUMMINS QSX15-CM570

It is suitable for CM570 engine control module. Engine type is QSX15 etc.

Table 25 - 50-Pin Connector

Terminals of controller	50 pins connector	Remark
Fuel relay output	38	Oil spout switch.
Starter relay output	-	Connect to starter coil directly.

Table 26 - 9-Pin Connector

Terminals of controller	9 pins connector	Remark
CAN GND	SAE J1939 shield-E	CAN communication shielding line (connect with ECU terminal only).
CAN(H)	SAE J1939 signal-C	Using impedance 120Ω connecting line.
CAN(L)	SAE J1939 return-D	Using impedance 120Ω connecting line.

Engine type: Cummins QSX15-CM570.

14.5 CUMMINS GCS-MOVBUS

It is suitable for GCS engine control module. RS485-MOVBUS is used to read information of engine. Engine types are QSX15, QST30, QSK23 / 45/60/78 and so on.

Table 27 - D-SUB Connector 06

Terminals of controller	D-SUB connector 06	Remark
Fuel relay output	5&8	Outside extend relay, when fuel outputs, make port 05 and 08 of the connector 06 connected.
Starter relay output	-	Connect to starter coil directly.

Table 28 - D-SUB Connector 06

Terminals of controller	D-SUB connector 06	Remark
RS485 GND	20	CAN communication shielding line (connect with ECU terminal only).
RS485+	21	Using impedance 120Ω connecting line.
RS485-	18	Using impedance 120Ω connecting line.

Engine type: Cummins QSK-Modbus, Cummins QST-Modbus, Cummins QSX-Modbus.

14.6 CUMMINS QSM11

Table 29 - Engine OEM Connector

Terminals of controller	OEM connector of engine	Remark
Fuel relay output	38	
Starter relay output	-	Connect with starter coil directly
CAN GND	-	CAN communication shielding line (connect with controller's this terminal only).
CAN(H)	46	Using impedance 120Ω connecting line.
CAN(L)	37	Using impedance 120Ω connecting line.

Engine type: common J1939.

14.7 CUMMINS QSZ13

Table 30 - Engine OEM Connector

Terminals of controller	OEM connector of engine	Remark
Fuel relay output	45	
Starter relay output	-	Connect to starter coil directly
Auxiliary output 1	16&41	Set to idle control, N/C output, by extending relay close 16 and 41 when controller is running at high speed.
Auxiliary output 2	19&41	Set to pulse speed raise control, N/O output, by extending relay, close 19 and 41 for 0.1s when controller enters warming up period.
CAN GND	-	CAN communication shielding line (connect with controller's this terminal only).
CAN(H)	1	Using impedance 120Ω connecting line.
CAN(L)	21	Using impedance 120Ω connecting line.

Engine type: Common J1939.

14.8 DETROIT DIESEL DDEC III / IV

Table 31 - Engine CAN Connector

Terminals of controller	CAN port of engine	Remark
Fuel relay output	Expand 30A relay, battery voltage of ECU is supplied by relay.	
Starter relay output	-	Connect to starter coil directly.
CAN GND	-	CAN communication shielding line (connect with controller's terminal only).
CAN(H)	CAN(H)	Using impedance 120Ω connecting line.
CAN(L)	CAN(L)	Using impedance 120Ω connecting line.

Engine type: Common J1939.

14.9 DEUTZ EMR2

Table 32 - F Connector

Terminals of controller	F connector	Remark
Fuel relay output	Expand 30A relay, battery voltage of 14 is supplied by relay. Fuse is 16A.	
Starter relay output	-	Connect to starter coil directly.
-	1	Connect to battery negative pole.
CAN GND	-	CAN communication shielding line (connect with controller's terminal only).
CAN(H)	12	Using impedance 120Ω connecting line.
CAN(L)	13	Using impedance 120Ω connecting line.

Engine type: VolvoEDC4.

14.10 JOHN DEERE

Table 33 - 21-Pin Connector

Terminals of controller	21 pins connector	Remark
Fuel relay output	G, J	
Starter relay output	D	
CAN GND	-	CAN communication shielding line (connect with controller's terminal only).
CAN(H)	V	Using impedance 120Ω connecting line.
CAN(L)	U	Using impedance 120Ω connecting line.

Engine type: John Deere.

14.11 MTU MDEC

It is suitable for MTU engines, 2000 series, 4000series.

Table 34 - X1 Pin Connector

Terminals of controller	X1 connector	Remark
Fuel relay output	BE1	
Starter relay output	BE9	
CAN GND	E	CAN communication shielding line (connect with one terminal only).
CAN(H)	G	Using impedance 120Ω connecting line.
CAN(L)	F	Using impedance 120Ω connecting line.

Engine type: mtu-MDEC-303.

14.12 MTU ADEC (SMART MODULE)

It is suitable for MTU engine with ADEC (ECU8) and SMART module.

Table 35 - ADEC (X1 Port)

Terminals of controller	ADEC (X1 port)	Remark
Fuel relay output	X1 10	X1 Terminal 9 connected to negative of battery.
Starter relay output	X1 34	X1 Terminal 33 connected to negative of battery.

Table 36 - ADEC (X4 Port)

Terminals of controller	SMART (X4 port)	Remark
CAN GND	X4 3	CAN communication shielding line (connect to controller's this terminal only).
CAN(H)	X4 1	Using impedance 120Ω connecting line.
CAN(L)	X4 2	Using impedance 120Ω connecting line.

Engine type: mtu-ADEC.

14.13 MTU ADEC (SAM MODULE)

It is suitable for MTU engine with ADEC (ECU7) and SAM module.

Table 37 - ADEC (X1 Port)

Terminals of controller	ADEC (X1 port)	Remark
Fuel relay output	X1 43	X1 Terminal 28 connected to negative of battery.
Start relay output	X1 37	X1 Terminal 22 connected to negative of battery.

Table 38 - SAM (X23 Port)

Terminals of controller	SAM (X23 port)	Remark
CAN GND	X23 3	CAN communication shielding line (connect with controller's this terminal only).
CAN(H)	X23 2	Using impedance 120Ω connecting line.
CAN(L)	X23 1	Using impedance 120Ω connecting line.

Engine type: Common J1939.

14.14 PERKINS

It is suitable for ADEM3/ ADEM4 engine control module. Engine type is 2306, 2506, 1106, and 2806.

Table 39 - Connector

Terminals of controller	Connector	Remark
Fuel relay output	1, 10, 15, 33, 34	
Starter relay output	-	Connect to starter coil directly.
CAN GND	-	CAN communication shielding line (connect with controller's terminal only).
CAN(H)	31	Using impedance 120Ω connecting line.
CAN(L)	32	Using impedance 120Ω connecting line.

Engine type: Perkins.

14.15 SCANIA

It is suitable for S6 engine control module. Engine type is DC9, DC12, and DC16.

Table 40 - B1 Connector

Terminals of controller	B1 connector	Remark
Fuel relay output	3	
Starter relay output	-	Connect to starter coil directly.
CAN GND	-	CAN communication shielding line (connect with controller's terminal only).
CAN(H)	9	Using impedance 120Ω connecting line.
CAN(L)	10	Using impedance 120Ω connecting line.

Engine type: Scania.

14.16 VOLVO EDC3

Suitable engine types: TAD1240, TAD1241, and TAD1242.

Table 41 - "Stand alone" Connector

Terminals of controller	"Stand alone" connector	Remark
Fuel relay output	H	
Starter relay output	E	
Auxiliary output 1	P	ECU power Set auxiliary output 1 as "ECU power".

Table 42 - "Data bus" Connector

Terminals of controller	"Data bus" connector	Remark
CAN GND	-	CAN communication shielding line (connect with controller's terminal only).
CAN(H)	1	Using impedance 120Ω connecting line.
CAN(L)	2	Using impedance 120Ω connecting line.

Engine type: Volvo.

NOTE: When this engine type is selected, preheating time should be set to at least 3 seconds.

14.17 VOLVO EDC4

Suitable engine types: TD520, TAD520 (optional), TD720, TAD720 (optional), TAD721, TAD722, and TAD732.

Table 43 - Connector

Terminals of controller	Connector	Remark
Fuel relay output	Expand 30A relay, and relay offers battery voltage for terminal14. Fuse is 16A.	
Starter relay output	-	Connect to starter coil directly.
	1	Connected to negative of battery.
CAN GND	-	CAN communication shielding line (connect with controller's terminal only).
CAN(H)	12	Using impedance 120Ω connecting line.
CAN(L)	13	Using impedance 120Ω connecting line.

Engine type: VolvoEDC4.

14.18 VOLVO-EMS2

Volvo Engine types are TAD734, TAD940, TAD941, TAD1640, TAD1641, and TAD1642.

Table 44 - Engine CAN Connector

Terminals of controller	Engine's CAN port	Remark
Auxiliary output 1	6	ECU stop; Set auxiliary output 1 as "ECU stop".
Auxiliary output 2	5	ECU power; Set auxiliary output 2 as "ECU power".
	3	Negative power.
	4	Positive power.
CAN GND	-	CAN communication shielding line (connect with controller's terminal only).
CAN(H)	1(Hi)	Using impedance 120Ω connecting line.
CAN(L)	2(Lo)	Using impedance 120Ω connecting line.

Engine type: Volvo-EMS2.

NOTE: When this engine type is selected, preheating time should be set to at least 3 seconds.

14.19 YUCHAI

It is suitable for Yuchai BOSCH common rail electric control engine.

Table 45 - Engine 42-Pin Connector

Terminals of controller	Engine 42 pins port	Remark
Fuel relay output	1.40	Connect to engine ignition lock.
Starter relay output	-	Connect to starter coil directly.
CAN GND	-	CAN communication shielding line (connect with controller's this terminal only).
CAN(H)	1.35	Using impedance 120Ω connecting line.
CAN(L)	1.34	Using impedance 120Ω connecting line.

Table 46 - Engine 2-Pin Connector

Battery	Engine 2 pins	Remark
Battery negative	1	Wire diameter 2.5mm ² .
Battery positive	2	Wire diameter 2.5mm ² .

Engine type: BOSCH.

14.20 WEICHAI

It is suitable for Weichai BOSCH common rail electric control engine.

Table 47 - Engine Connector

Terminals of controller	Engine port	Remark
Fuel relay output	1.40	Connect to engine ignition lock.
Starter relay output	1.61	
CAN GND	-	CAN communication shielding line (connect with controller's this terminal only).
CAN(H)	1.35	Using impedance 120Ω connecting line.
CAN(L)	1.34	Using impedance 120Ω connecting line.

Engine type: GTSC1.

NOTE: If there is any problem of connection between controller and ECU communication, please feel free to contact SmartGen's service.

15 ETHERNET INTERFACE

15.1 ILLUSTRATION

ETHERNET port, used for controller monitoring, can realize network client connection.

NOTE: After changing controller network parameters (e.g. IP address, subnet mask etc.) new settings will take effect only after the controller is restarted.

15.2 NETWORK CLIENT CONNECTION

When the controller is used as network client, it can be monitored via network port by using TCP ModBus protocol.

The procedure is as below:

- Set IP address and subnet mask of the controller. The IP address must be in the same network segment as the IP address of monitoring equipment (e.g. PC), but different from each other. e.g.: if monitoring equipment IP address is 192.168.0.16, controller IP can be 192.168.0.18, subnet mask is 255.255.255.0.
- Connect the controller. It can be connected to the monitoring equipment directly by using network cable or via exchanger.
- The communication between the controller and monitoring equipment is carried out by using TCP ModBus protocol.

NOTE: In this connection mode controller parameters can be set. SmartGen provides testing software for this connection mode. Communication protocol can be obtained from the SmartGen service.

15.3 DESCRIPTION OF CONTROLLER CONNECTION CABLE

Table 48 - Controller Internet Access

No.	Name	Description
1	TX+	Tranceive Data+
2	TX-	Tranceive Data-
3	RX+	Receive Data+
4	NC	Not connected
5	NC	Not connected
6	RX-	Receive Data-
7	NC	Not connected
8	NC	Not connected

- Controller connects with PC with a piece of cable line directly.
For this connection crossover cable must be used.
Crossover cable: EIA/TIA 568A standard on one end and EIA/TIA 568B on the other end.

NOTE: If PC network port has Auto MDI/MDIX function, parallel cable can also be used.

- Controller and PC connection is done via exchanger (or router).
Parallel lines must be used.
Parallel cable: EIA/TIA 568A standard on both ends or EIA/TIA 568B standard on both ends.

NOTE: If switchboard (or router) network port has Auto MDI/MDIX function, crossover cable can also be used.

16 TROUBLESHOOTING

Table 49 - Troubleshooting

Symptoms	Possible Solutions
Controller no response with power	Check starting batteries; Check controller connection wirings; Check DC fuse.
Genset shutdown	Check the water/cylinder temperature is too high or not; Check the genset AC voltage; Check DC fuse.
Controller emergency stop	Check emergence stop button is correct or not; Check whether the starting battery positive is connected with the emergency stop input correctly; Check whether the circuit is open.
Low oil pressure alarm after crank disconnect	Check the oil pressure sensor and its connections.
High water temp. alarm after crank disconnect	Check the temperature sensor and its connections.
Shutdown alarm in running	Check related switch and its connections according to the information on LCD; Check programmable inputs.
Crank not disconnect	Check fuel circuit and its connections; Check starting batteries; Check speed sensor and its connections; Refer to engine manual.
Starter no response	Check starter connections; Check starting batteries.
Genset running while ATS not transfer	Check ATS; Check the connections between ATS and controllers.
RS485 communication abnormal	Check connections; Check COM settings are correct or not; Check A and B wires of RS485 are connected reversely or not; Check whether RS485 transfer module is damaged or not; Check whether communication port of PC is damaged or not.
ECU communication failure	Check connections of CAN high and low polarity; Check if 120Ω resistor is connected correctly; Check if engine type selection is right or not; Check if controller and engine connection wiring is right or not, and whether output setting is right or not.
ECU warning or stop	Get information from alarm page of LCD; If there is detailed alarm, check engine according to description. If not, please refer to engine manual according to SPN alarm code.