



SmartGen[®]
ideas for power

HGM7110DC DC Genset Controller

USER MANUAL



ZHENGZHOU SMARTGEN TECHNOLOGY CO.,LTD



Chinese trademark

SmartGen[®] English trademark

Smartgen — make your generator *smart*

Smartgen Technology Co., Ltd.

No. 28 Jinsuo Road

Zhengzhou

Henan Province

P. R. China

Tel: +86-371-67988888/67981888

+86-371-67991553/67992951

+86-371-67981000(overseas)

Fax: 0086-371-67992952

Web: <http://www.smartgen.com.cn>

<http://www.smartgen.cn>

Email: sales@smartgen.cn

All rights reserved. No part of this publication may be reproduced in any material form (including photocopying or storing in any medium by electronic means or other) without the written permission of the copyright holder.



Smartgen Technology reserves the right to change the contents of this document without prior notice.

Version history

Date	Version	Contents
2014-09-27	1.0	Original release

This manual is suitable for HGM7110DC controller only.

Clarification of notation used within this publication.

SIGN	INSTRUCTION
 Note	Highlights an essential element of a procedure to ensure correctness.
 Caution!	Indicates a procedure or practice, which, if not strictly observed, could result in damage or destruction of equipment.
 Warning!	Indicates error operation may cause death, serious injury and significant property damage.

SmartGen

Contents

1	OVERVIEW	6
2	PERFORMANCE AND CHARACTERISTICS	7
3	SPECIFICATION	10
4	OPERATION.....	11
4.1.	PUSHBUTTONS.....	11
4.2.	LCD DISPLAY	12
4.2.1.	MAIN DISPLAY.....	12
4.2.2.	PARAMETERS SETTING MENU.....	12
4.3.	AUTO START/STOP OPERATION.....	15
4.4.	MANUAL START/STOP OPERATION.....	17
5	SWITCH CONTROL PROCEDURES	18
5.1	ACCUMULATOR/GENSET PRIORITY SYSTEM:.....	18
5.2	TWO ACCUMULATOR PRIORITY SYSTEM	20
6	PROTECTIONS.....	22
6.1	WARNING ALARMS	22
6.2	SHUTDOWN ALARM.....	24
6.3	TRIP AND STOP ALARM.....	26
6.4	TRIP ALARM.....	27
7	WIRING CONNECTION	28
8	SCOPES AND DEFINITIONS OF PROGRAMMABLE PARAMETERS.....	31
8.1	CONTENTS AND SCOPES OF PARAMETERS	31
8.2	PROGRAMMABLE OUTPUT PORTS	42
8.2.1	DEFINED COMBINATION OUTPUT.....	45
8.3	PROGRAMMABLE INPUT PORTS (ALL ACTIVE WHEN CONNECT TO GRAND (B-))	47
8.4	SELECTION OF SENSORS.....	50
8.5	CONDITIONS OF CRANK DINSCONNECT SELECTION.....	51
9	SENSORS SETTING	52
10	COMMISSIONING	53
11	TYPICAL APPLICATION	54
12	INSTALLATION	55
13	GSM SHORT MESSAGE ALARM AND REMOTE CONTROL.....	57
13.1	GSM SHORT MESSAGE ALARM	57
13.2	GSM SHORT MESSAGE REMOTE CONTROL	58
14	CONNECTIONS OF CONTROLLER WITH J1939 ENGINE	60
14.1	CUMMINS ISB/ISBE	60
14.2	CUMMINS QSL9.....	60
14.3	CUMMINS QSM11 (import)	61

14.4	CUMMINS QSX15-CM570	61
14.5	CUMMINS GCS-MODBUS	62
14.6	DETROIT DIESEL DDEC III / IV	62
14.7	DEUTZ EMR2	63
14.8	JOHN DEERE	63
14.9	MTU MDEC	64
14.10	PERKINS	64
14.11	SCANIA	65
14.12	VOLVO EDC3	65
14.13	VOLVO EDC4	66
14.14	VOLVO-EMS2	66
14.15	BOSCH	67
15	FAULT FINDING	68

SmartGen

1 OVERVIEW

HGM7110DC genset controller is used for genset automation and monitor control system of single unit to achieve automatic start/stop, data measurement, alarm protection and “three remote” (remote control, remote measuring and remote communication). The controller adopts large liquid crystal display (LCD) and selectable Chinese, English or other languages interface with easy and reliable operation.

HGM7110DC controller adopts 32 bits micro-processor technology with precision parameters measuring, fixed value adjustment, time setting and threshold adjusting and etc. The majority of parameters can be set using front panel and all the parameters can be set using PC (via USB port) and can be adjusted and monitored with the help of RS485 ports. It can be widely used in all types of automatic genset control system with compact structure, advanced circuits, simple connections and high reliability.

SmartGen

2 PERFORMANCE AND CHARACTERISTICS

HGM7110DC: Control the genset to start/stop by detecting the accumulator voltage or charger current.

- With ARM-based 32-bit SCM, highly integrated hardware, new reliability level;
- 132x64 LCD with backlight, multilingual interface (including English, Chinese or other languages) which can be chosen at the site, making commissioning convenient for factory personnel;
- Improved LCD wear-resistance and scratch resistance due to hard screen acrylic;
- Silicon rubber panel and pushbuttons for better operation in high/low temperature environment;
- RS485 communication port enables remote control, remote measuring, remote communication via ModBus protocol.
- Equipped with SMS (Short Message Service) function. When genset is alarming, controller can send short messages via SMS automatically to max. 5 telephone numbers. Besides, generator status can be controlled and checked using SMS.
- Equipped with CANBUS port and can communicate with J1939 genset. Not only can you monitoring frequently-used data (such as water temperature, oil pressure, speed, fuel consumption and so on) of ECU machine, but also control starting up, shutdown , raising speed and speed droop via CANBUS port.
- Suitable for Accumulator Priority System, Generator Priority System, Or Double Accumulator System;
- Accumulator Priority System : The accumulator supplies the power for load continuously. In Auto mode, the genset will start automatically to charger the accumulator if the accumulator voltage has fallen below the “Charge Start Voltage”.
- Generator Priority System: The generator supplies the power for load continuously. If there is shutdown alarm occurs by either engine or generator, the accumulator will supply the power for load. In Auto mode, the genset will charge the accumulator if the accumulator voltage has fallen below the “Charge Start Voltage”; When the accumulator voltage has fallen below the “Nominal Voltage”, in addition, the generator abnormal condition occurs, Shutdown alarm will be initiated
- Double Accumulator System: Firstly, the accumulator 1# supplies the power for load; if the accumulator 1# satisfies the charger requirement, then it will charged by the genset and the accumulator 2# supplies the power for load.

- Collects and shows parameters:

Accumulator

Accumulator Voltage (after the compensation)

Accumulator Temperature

Accumulator Charge Current

Accumulator Discharge Current

Load

Current

Generator Current

- Accumulator over voltage, under voltage protection functions;
- 3 fixed analog sensors (temperature, oil pressure and liquid level);
- 2 configurable sensors can be set as sensor of temperature, oil pressure or fuel level;
- Precision measure and display parameters about Engine,
 - Temp. (WT) °C/°F both be displayed
 - Oil pressure (OP) kPa/Psi/Bar all be displayed
 - Fuel level (FL) %(unit)
 - Speed (SPD) r/min (unit)
 - Voltage of Battery (VB) V (unit)
 - Voltage of Charger (VD) V (unit)
 - Hour count (HC) can accumulate to max. 65535 hours.
 - Start times can accumulate to max. 65535 times.
- Protection: automatic start/stop of the genset, perfect fault indication and protection function;
- All output ports are relay-out;
- Parameter setting: parameters can be modified and stored in internal FLASH memory and cannot be lost even in case of power outage; most of them can be adjusted using front panel of the controller and all of them can be modified using PC via USB or RS485 ports.
- More kinds of curves of temperature, oil pressure, fuel level can be used directly and users can define the sensor curves by themselves;
- Multiple crank disconnect conditions (speed sensor, oil pressure) are optional;
- Widely power supply range DC(8~35)V, suitable to different starting battery voltage environment;
- Event log, real-time clock and Scheduled start & stop function (can be set as start genset

once a day/week/month);

- Can be used as an indicating instrument (indicate and alarm are enable only, relay is inhibited);
- With maintenance function. Actions (warning, shutdown) can be set when maintenance time out;
- All parameters used digital adjustment, instead of conventional analog modulation with normal potentiometer, more reliability and stability;
- Waterproof security level IP55 due to rubber seal installed between the controller enclosure and panel fascia;
- Metal fixing clips enable perfect in high temperature environment;
- Modular design, self-extinguishing ABS plastic enclosure, pluggable connection terminals and embedded installation way; compact structure with easy mounting.











SmartGen

3 SPECIFICATION





Parameter	Details
Working Voltage	DC8. 0V to 35. 0V, continuous power supply
Overall Consumption	<3W (Standby mode: ≤2W)
Speed Sensor Voltage	1. 0 V to 24 V (RMS)
Speed Sensor Frequency	Maximum 10,000 Hz
Start Relay Output	16A DC28V power supply output
Fuel Relay Output	16A DC28V power supply output
Configurable Relay Output 1	7A DC28V power supply output
Configurable Relay Output 2	7A AC250V passive output
Configurable Relay Output 3	16A AC250V passive output
Configurable Relay Output 4	16A AC250V passive output
Configurable Relay Output 5	7A DC28V power supply output
Configurable Relay Output 6	7A DC28V power supply output
Case Dimensions	197mm x 152mm x 47mm
Panel Cutout	186mm x 141mm
Working Conditions	Temperature: (-25~+70)°C Humidity: (20~93)%RH
Storage Conditions	Temperature:(-25~+70)°C
Protection Level	IP55 Gasket
Insulation Intensity	Apply AC2.2kV voltage between high voltage terminal and low voltage terminal; The leakage current is not more than 3mA within 1min.
Weight	0.75kg

4 OPERATION

4.1. PUSHBUTTONS

	Stop	Stop running generator in Auto/Manual mode; Lamp test (press at least 3 seconds); Reset alarm in stop mode; During stopping process, press this button again to stop generator immediately.
	Start	Start genset in Manual mode.
	Manual Mode	Press this key and controller enters in Manual mode.
	Auto Mode	Press this key and controller enters in Auto mode.
	Close/Open	Can control generator to switch on or off in Manual mode.
	Mute/Reset Alarm	Alarming sound off; If there is trip alarm, pressing the button at least 3 seconds can reset this alarm.
	Raise Speed	Control the genset accelerate in Manual mode.
	Drop Speed	Control the genset decelerate in Manual mode.
	Menu/Confirm	1) Enter into Menu interface; 2) Shift cursor and confirm the set information.
	Up/Increase	1) Screen scroll; 2) Up cursor and increase value in setting menu.
	Down/Decrease	1) Screen scroll; 2) Down cursor and decrease value in setting menu.



NOTE: Pressing  to enter into Menu interface; select “Parameters” and input correct passwords allows the users to set parameters.

NOTE: Pressing  and  simultaneously will increase LCD contrast; Pressing  and  simultaneously will decrease LCD contrast; When controller is powered on after outage, LCD contrast will return factory default.

WARNING: Default password is 00318, user can change it in case of others change the advanced parameters setting. Please clearly remember the password after changing. If you forget it, please contact Smartgen services and send all information in the controller page of “ABOUT” to us.

4.2. LCD DISPLAY

4.2.1. MAIN DISPLAY

Main screen show pages; use   to scroll the screen.

★**Main Screen**, including as below,

Genset status, ATS status, Accumulator voltage, Accumulator temperature, Generator Current, Accumulator Charge Current, Accumulator Discharge Current, Load current, Engine speed

★**Accumulator Charging Curve Screen**, including as below,

Charge Start Voltage, Const Charge Voltage, Charge Stop Voltage, Accumulator Voltage, Accumulator Current, Charging Status

★**Engine 1#**, including as below,

Engine Speed, GOV/AVR, Engine Temperature, Engine Oil Pressure

★**Engine 1#**, including as below,

Liquid (Fuel) Level, Controller Voltage, Charger Voltage, Configure Analog 1

▲ **NOTE:** If connected with J1939 engine via CANBUS port, this page also includes: coolant pressure, coolant level, fuel temperature, oil pressure, inlet temperature, exhaust temperature, turbo pressure, total fuel consumption and so on.(different engine with different parameters)

★**Acc. Information**, including as below,

Total Running Time, Total Start Times, Maintenance Due

★**Alarm:**

Display all of alarm information.

▲ **NOTE:** For ECU alarms and shutdown alarms, if the alarm information is displayed, check engine according to it, otherwise, please check the manual of generator according to SPN alarm code.

★Press  can enter into menu interface to viewing the following items: event log; input/output ports status; Issue time of software and hardware version; Time and Date

★**Event Log**, including as below,

Records all start/stop events (shutdown alarm, trip and stop alarm, manual /auto start or stop) and the real time when alarm occurs.

4.2.2. PARAMETERS SETTING MENU

Parameters setting including as following,

★**Charge Settings**

- ★Timer settings
- ★Engine settings
- ★Load settings
- ★ATS settings
- ★Analog sensor settings
- ★Input port settings
- ★Output port settings
- ★Module settings
- ★Scheduling and maintenance settings
- ★GSM settings





Example:





Advanced Parameters	Form 1:
> Charge	Use to scroll settings, to enter settings (form 2), to exit settings menu.
> Timer	
> Engine	
> Load	

Charge	Form 2:
> Return	Use to scroll settings (form 3); select “return” and press to return to previous menu (form 1), or press to return to previous menu (form 1).
> 1# Bat Rated Voltage	
>2# Bat Rated Voltage	
> 1# Battery Num	





Charge	Form 3:
> Charge Stop Current	Use to scroll settings, to confirm settings (form 4), to return to previous menu. (form 1)
> Float Charge Volt	
> Nominal Voltage	
> Charge OC	

Charge OC	Form 4:
Sel: Disable	Use to enter settings (form 5), to scroll settings, to return to previous menu. (form 3)
Set Value: 00110%	
Return Value: 00108%	
Delay: 00005	

Charge OC	Form 5:
Sel: Disable	Use   to scroll settings (form 6),  to enter settings
Set Value: 00110%	(form 7),  to exit settings menu. (form 4)
Return Value: 00108%	
Delay: 00005	

Charge OC	Form 6:
Sel: Disable	Use   to scroll settings (form 5),  to enter settings
Set Value: 00110%	(form 7),  to exit settings menu. (form 4)
Return Value: 00108%	
Delay: 00005	

Charge OC	Form 7:
Sel: Enable	Use   to scroll settings (form 5),  to enter settings,
Set Value: 00110%	 to exit settings menu. (form 4)
Return Value: 00108%	
Delay: 00005	

Charge OC	Form 8:
Sel: Disable	Use   to scroll settings,  to enter settings (form 4),
Set Value: 00110%	 to exit settings menu. (form 4)
Return Value: 00108%	
Delay: 00005	

 **NOTE:** Long time pressing  can exit setting directly during setting.

4.3. AUTO START/STOP OPERATION

Auto mode is selected by pressing the  button; a LED besides the button will illuminate to confirm the operation.

Starting Sequence:

1. When the accumulator voltage has fallen below the “Charge Start Voltage” or when “Remote Start (with load)” is active, “Start Delay” timer is initiated. “Start Delay” countdown will be displayed on LCD display;
2. When start delay is over, preheat relay energizes (if configured), “preheat delay XXs” information will be displayed on LCD display;
3. After the above delay, the Fuel Relay (if configured) is energized, and then one second later, the Start Relay is engaged. The engine is cranked for a pre-set time. If the engine fails to fire during this cranking attempt then the fuel relay and start relay are disengaged for the pre-set rest period; “crank rest time” begins and wait for the next crank attempt.
4. Should this start sequence continue beyond the set number of attempts, the start sequence will be terminated, and Fail to Start fault will be displayed on LCD display.
5. In case of successful crank attempt, the “Safety On” timer is activated, allowing Low Oil Pressure, High Temperature, Under speed and Charge Alternator Failure inputs to stabilise without triggering the fault. As soon as this delay is over, “Waiting For Load” delay is initiated.
6. If the on-load requirements have been reached, then the generator close relay will be energized and the constant-current charge status is settled. The generator will regulate GOV/AVR voltage automatically according to the charging current; If the GOV/AVR voltage has reached its maximum value while the charging current is lower than the “Rated Charge Current”, Charge Fault alarm will be initiated.

▲NOTE: Charge Stop Mode: Charge Current + Volt. The accumulator charges the genset with the preset rated charging current (charge type: constant current). When the accumulator voltage has exceeded the “constant voltage value”, enter into the “Constant Voltage Charge” status. During the “Constant Voltage Charge” status, the accumulator charges the genset with its minimum charging current as soon as the minimum value is reached. After the accumulator voltage has reached the “Charge Stop Voltage”, the charging is finished and the genset is enter into “Stop Mode”.

Charge Stop Mode: Charge Delay. The accumulator charges the genset with the preset rated charging current (charge type: constant current). When the accumulator voltage has







exceeded the “constant voltage value”, enter into the “Constant Voltage Charge” status and this status will last for preset time.

Automatic Stop Sequence,

- 1) When the genset is charged or when the “Remote Start” signal is removed, the Stop Delay is initiated. Once this “stop delay” has expired, the Generator Breaker will open and the “Cooling Delay” is then initiated.
- 2) After the “Cooling Delay”, "Fail to Stop Delay" begins, fuel relay is de-energized, complete stop is detected automatically.
- 3) When generator is stop completely, “After stop” delay will be initiated. Otherwise, fail to stop alarm is initiated and the corresponding alarm information is displayed on LCD display. (If generator is stop successfully after “fail to stop” alarm has initiated, “After stop” delay will be initiated and the alarm will be removed).
- 4) Generator is placed into its standby mode after its “After stop” delay.

SmartGen

4.4. MANUAL START/STOP OPERATION

- 1 Manual mode is selected by pressing the  button; a LED besides the button will illuminate to confirm the operation; Then press  button to start the generator, it can automatically judge crank success and accelerate to high speed running. If high temperature, low oil pressure, over speed and abnormal voltage occur during genset running, controller can effectively protect genset to stop (detail procedures please refer to No.2~6 of Auto Start Sequence). If generator is normal, users can energize “Gen Close Relay” manually via  button or adjust engine speed manually via   button in order to let the accumulator is charged.
- 2 Manual stop: pressing  key can shut down the running genset. (detail procedures please refer to No.2~4 of **Auto Stop Sequence**)

▲ NOTE: Manual start/stop operations are used for Test only.

5 SWITCH CONTROL PROCEDURES

5.1 ACCUMULATOR/GENSET PRIORITY SYSTEM:

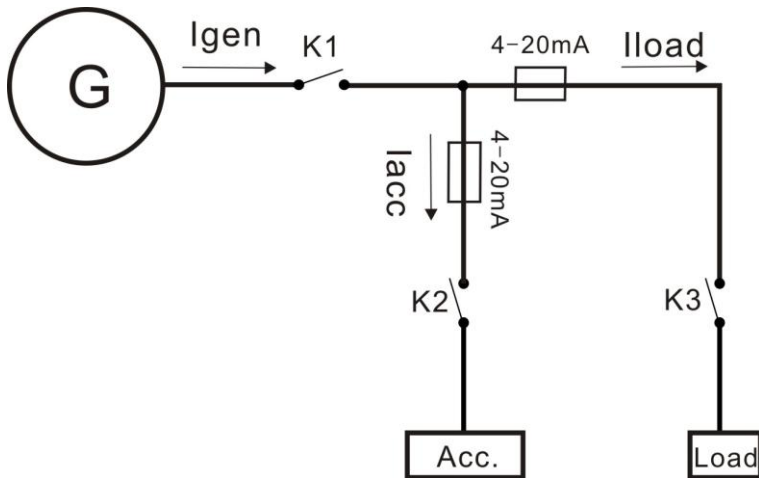

Charging: $I_{gen} = I_{acc} + I_{load}$;
 Non-charging: $I_{gen} = 0$, $I_{acc} = -I_{load}$;

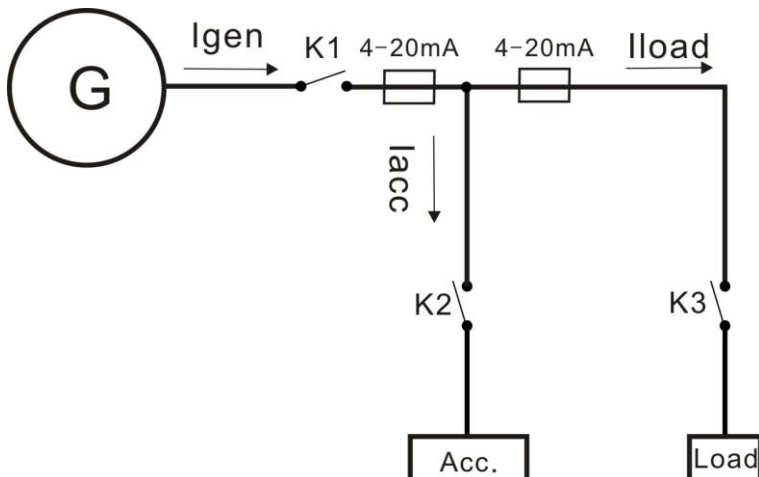

Charging: $I_{acc} = I_{gen} - I_{load}$;
 Non-charging: $I_{acc} = -I_{load}$;

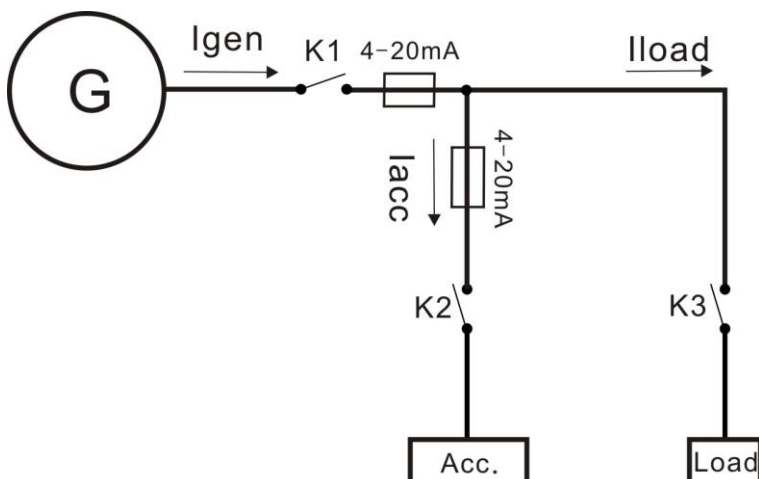

Charging: $I_{load} = I_{gen} - I_{acc}$;

Non-charging: $I_{acc} = xxx$, $I_{load} = xxx$, $I_{gen} = 0$;

Accumulator Priority System: In Auto mode, K2 and K3 are always close. When the accumulator voltage has fallen below the Charge Start Volt, the genset will be started according to the preset sequence. If the on-load requirements have been reached, K1 Close relay will activate to charge the accumulator.

Genset Priority System: In Auto mode, K1 and K3 are always close. When the accumulator voltage has fallen below the Charge Start Volt, the genset will be started according to the preset sequence. If the on-load requirements have been reached, K2 Close relay will activate to charge the accumulator. If Genset failure occurs, K2 Close relay will activate and the Accumulator will take load.

SmartGen

5.2 TWO ACCUMULATOR PRIORITY SYSTEM

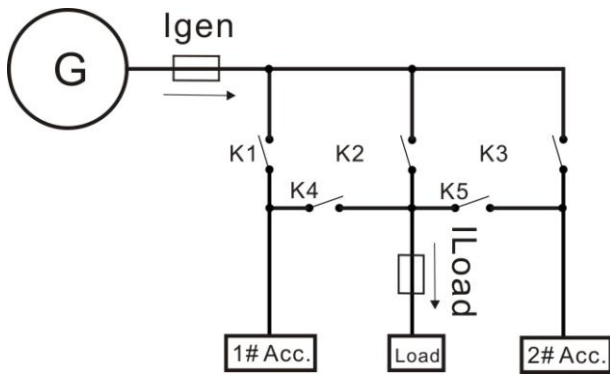

1# Acc Charging: $i_{acc1} = I_{gen}$;

1# Acc on-load: $i_{acc1} = -I_{load}$;

2# Acc Charging: $i_{acc2} = I_{gen}$;

2# Acc on-load: $i_{acc2} = -I_{load}$;

1. Accumulator Switching Mode: Gap

1# Accumulator take load (K4 is closed); When the 1# accumulator voltage has fallen below the Charge Start Volt, K4 open relay will active, after 10s delay, 2# Accumulator take load (K5 is closed). During the above transfer process, the load is disconnect; The genset will be started according to the preset sequence to charge the 1# Accumulator (K1 is closed).

Same procedures as above when 2# Accumulator transfer to 1# Accumulator.

2. Two Accumulator Switching Mode: Continuous

1# Accumulator take load (K4 is closed); When the 1# accumulator voltage has fallen below the Charge Volt, 2# accumulator voltage will be recorded and the genset voltage detection begins; The genset will be started according to the preset sequence; When the genset voltage rise to 1# accumulator voltage, K2 close relay will active and genset takes load. After 1s delay, K4 open relay will active. Adjust the genset voltage to reach to 2# accumulator voltage, then 2# accumulator takes load (K5 is closed), K2 open relay active. After 1s delay, K1 close relay active to charge the 1# accumulator.

Same procedures as above when 2# Accumulator transfer to 1# Accumulator.

NOTE: All above switch actions can be implemented when the controller is in Auto mode.

MANUAL TRANSFER PROCEDURES:

Accumulator Priority: K2 and K3 are always close. Press button, if generator have taken load (K1 Close), will output unload signal (K1 Open); if taken no load (K1 Open), generator will output load signal (K1 Close);

Generator Priority: K1 and K3 are always close. Press button, if Accumulator have taken

load (K2 Close), will output unload signal (K2 Open); if taken no load (K2 Open), accumulator will output load signal (K2 Close);

Two accumulators Priority: In Manual mode, only genset will be started and the ATS will not act.

AUTO TRANSFER PROCEDURES:

1. If input port is configured as Close Generator Auxiliary

◆ If “Open breaker detect” is “SELECT Enable”

Generator load is transferred into generator un-load or accumulator load is transferred into accumulator un-load or accumulator is full charged, after the open delay; switch off signal will be output while “fail to transfer” delay will be initiated. Once the delay has expired, if switch off failed, it will wait for switch off. Otherwise, switch off is completed.

Generator unload is transferred into generator load or accumulator unload is transferred into accumulator load or accumulator charge is beginning, after the close delay, switch on signal will be output while “fail to transfer” delay will be initiated. Once the delay has expired, if switch on failed, it will wait for switch on. Otherwise, switch on is completed.

If “fail to transfer” warn is “Enable”, alarm signal will be initiated whatever switch on or off failure.

◆ If “Open breaker detect” is “SELECT Disable”

Generator load is transferred into generator unload or accumulator load is transferred into accumulator un-load or accumulator is full charged, after the open delay, switch off is completed.

Generator unload is transferred into generator load or accumulator unload is transferred into accumulator load or accumulator charge is beginning, after the close delay, switch on signal will be output while “fail to transfer” delay will be initiated. Once the delay has expired, if switch on failed, it will wait for switch on. Otherwise, switch on is completed.

If “fail to transfer” warn is “Enable”, alarm signal will be initiated f switch on failure.

2. If input port is *NOT* configured as Close Generator Auxiliary

Generator un-load is transferred into generator load, close generator output.

Generator load is transferred into generator un-load, open generator output.

6 PROTECTIONS

6.1 WARNING ALARMS

Warnings are not shutdown alarms and do not affect the operation of the gen-set. Warning alarms does not lead to shutdown. Warning alarms types are as follows:

No.	Type	Description
1	Over Speed	When the controller detects that the genset speed has exceeded the pre-set value, it will initiate a warning alarm.
2	Under Speed	When the controller detects that the genset speed has fallen below the pre-set value, it will initiate a warning alarm.
3	Loss of Speed Signal	When the controller detects that the genset speed is 0 and the action select "Warn", it will initiate a warning alarm.
4	Gen Over Current	When the controller detects that the genset current has exceeded the pre-set value and the action select "Warn", it will initiate a warning alarm.
5	Fail To Stop	After "fail to stop" delay, if gen-set does not stop completely, it will initiate a warning alarm.
6	Charge Alternator Failure	When the controller detects that charger voltage has fallen below the pre-set value, it will initiate a warning alarm.
7	Battery Over Volt	When the controller detects that genset battery voltage has exceeded the pre-set value, it will initiate a warning alarm.
8	Battery Under Volt	When the controller detects that genset battery voltage has fallen below the pre-set value, it will initiate a warning alarm.
9	Maintenance Due	When count down time is 0 and the action select "Warn", it will initiate a warning alarm.
10	ECU Warn	If an error message is received from ECU via J1939, it will initiate a warning alarm.
11	Switch Fail Warn	When the controller detects that the breaker close or open failure occurs, and the action select "Warn", it will initiate a warning alarm.
12	Temperature Sensor Open Circuit	When the controller detects that the temperature sensor is open circuit and the action select "Warn", it will initiate a warning alarm.
13	High Temperature	When the controller detects that engine temperature has exceeded the pre-set value, it will initiate a warning alarm.
14	Low Temperature	When the controller detects that engine temperature has fallen below the pre-set value, it will initiate a warning alarm.
15	Oil Pressure Open Circuit	When the controller detects that the oil pressure sensor is open circuit and the action select "Warn", it will initiate a warning alarm.

No.	Type	Description
16	Low Oil Pressure	When the controller detects that the oil pressure has fallen below the pre-set value, it will initiate a warning alarm.
17	Level Sensor Open Circuit	When the controller detects that the level sensor is open circuit and the action select "Warn", it will initiate a warning alarm.
18	Low Fuel Level	When the controller detects that the fuel level has fallen below the pre-set value, it will initiate a warning alarm.
19	Flexible Sensor 1 Open Circuit	When the controller detects that the flexible sensor 1 is open circuit and the action select "Warn", it will initiate a warning alarm.
20	Flexible Sensor 1 High	When the controller detects that the sensor 1 value has exceeded the pre-set value, it will initiate a warning alarm.
21	Flexible Sensor 1 Low	When the controller detects that the sensor 1 value has fallen below the pre-set value, it will initiate a warning alarm.
22	Flexible Sensor 2 Open Circuit	When the controller detects that the flexible sensor 2 is open circuit and the action select "Warn", it will initiate a warning alarm.
23	Flexible Sensor 2 High	When the controller detects that the sensor 2 value has exceeded the pre-set value, it will initiate a warning alarm.
24	Flexible Sensor 2 Low	When the controller detects that the sensor 2 value has fallen below the pre-set value, it will initiate a warning alarm.
25	Digital Input	When digit input port is set as warning and the alarm is active, it will initiate a warning alarm.
26	GSM COM Failure	When GSM is enable but the controller couldn't detect GSM module, it will initiate a warning alarm.
27	1#Acc. Over Voltage Warn	When the controller detects that the 1# accumulator battery voltage has exceeded the pre-set value, it will initiate a warning alarm.
28	1#Acc. Under Voltage Warn	When the controller detects that 1# accumulator voltage has fallen below the pre-set value, it will initiate a warning alarm.
29	2#Acc. Over Voltage Warn	When the controller detects that the 2# accumulator battery voltage has exceeded the pre-set value, it will initiate a warning alarm.
30	2#Acc. Under Voltage Warn	When the controller detects that 2# accumulator voltage has fallen below the pre-set value, it will initiate a warning alarm.
31	Charge Over Current	When the controller detects that the accumulator current has exceeded the pre-set value and the action select "Warn", it will initiate a warning alarm.
32	Charge Over Time	If the charging is not finished within the preset time, and the action select "Warn", it will initiate a warning alarm.

6.2 SHUTDOWN ALARM

When controller detects shutdown alarm, it will send signal to open breaker and shuts down generator.

Shutdown alarms as following:

No.	Type	Description
1	Emergency Stop	When the controller detects an emergency stop alarm signal, it will initiate a shutdown alarm.
2	Over Speed	When the controller detects that the generator speed has exceeded the pre-set value, it will initiate a shutdown alarm.
3	Under Speed	When the controller detects that the generator speed has fallen below the pre-set value, it will initiate a shutdown alarm.
4	Loss of Speed Signal	When the controller detects that the generator speed is 0 and the action select "Shutdown", it will initiate a shutdown alarm.
5	Fail To Start	If the engine does not fire after the pre-set number of attempts, it will initiate a shutdown alarm.
6	Gen Over Current	When the controller detects that the genset current has exceeded the pre-set value and the action select "Shutdown", it will initiate a shutdown alarm.
7	Maintenance Due	When count down time is 0 and the action select "Shutdown", it will initiate a shutdown alarm.
8	ECU Shutdown	If an error message is received from ECU via J1939, it will initiate a shutdown alarm.
9	ECU Com Fail	If an error message is <i>NOT</i> received from ECU via J1939, it will initiate a shutdown alarm.
10	Aux High Temp	The controller will initiate a shutdown alarm if the input is active.
11	Aux Low OP	The controller will initiate a shutdown alarm if the input is active.
12	Temperature Sensor Open Circuit	When the controller detects that the temperature sensor is open circuit and the action select "Shutdown", it will initiate a shutdown alarm.
13	High Temperature	When the controller detects that engine temperature has exceeded the pre-set value, it will initiate a shutdown alarm.
14	Oil Pressure Open Circuit	When the controller detects that the oil pressure sensor is open circuit and the action select "Shutdown", it will initiate a shutdown alarm.
15	Low Oil Pressure	When the controller detects that the oil pressure has fallen below the pre-set value, it will initiate a shutdown alarm.

No.	Type	Description
16	Level Sensor Open Circuit	When the controller detects that the level sensor is open circuit and the action select "Shutdown", it will initiate a shutdown alarm.
17	Flexible Sensor 1 Open Circuit	When the controller detects that the flexible sensor 1 is open circuit and the action select "Shutdown", it will initiate a shutdown alarm.
18	Flexible Sensor 1 High	When the controller detects that the sensor 1 value has exceeded the pre-set value, it will initiate a shutdown alarm.
19	Flexible Sensor 1 Low	When the controller detects that the sensor 1 value has fallen below the pre-set value, it will initiate a shutdown alarm.
20	Flexible Sensor 2 Open Circuit	When the controller detects that the flexible sensor 2 is open circuit and the action select "Shutdown", it will initiate a shutdown alarm.
21	Flexible Sensor 2 High	When the controller detects that the sensor 2 value has exceeded the pre-set value, it will initiate a shutdown alarm.
22	Flexible Sensor 2 Low	When the controller detects that the sensor 2 value has fallen below the pre-set value, it will initiate a shutdown alarm.
23	Digital Input	When digit input port is set as shutdown and the alarm is active, it will initiate a shutdown alarm.
24	1#Acc. Over Voltage	When the controller detects that the 1# accumulator battery voltage has exceeded the pre-set value, it will initiate a shutdown alarm.
25	1#Acc. Under Voltage	When the controller detects that 1# accumulator voltage has fallen below the pre-set value, it will initiate a shutdown alarm.
26	Charge Over Current	When the controller detects that the accumulator current has exceeded the pre-set value and the action select "Shutdown", it will initiate a shutdown alarm.
27	Charge Over Time	If the charging is not finished within the preset time, and the action select "Shutdown", it will initiate a shutdown alarm.
28	Charge Fault	If GOV output is 100%, and the charge current has fallen below the rated charge current, it will initiate a shutdown alarm.
29	Two Acc. Fault	In Two Accumulator mode, if both accumulator are satisfy the start requirement, it will initiate a shutdown alarm.
30	2#Acc. Over Voltage	When the controller detects that the 2# accumulator battery voltage has exceeded the pre-set value, it will initiate a shutdown alarm.
31	2#Acc. Under Voltage	When the controller detects that 2# accumulator voltage has fallen below the pre-set value, it will initiate a shutdown alarm.

6.3 TRIP AND STOP ALARM

On initiation of the trip and stop condition the controller will de-energize the ‘Close Generator’ Output to remove the load from the generator. Once this has occurred the controller will start the Cooling delay and allow the engine to cool before shutting down the engine.

No.	Type	Description
1	Gen Over Current	When the controller detects that the genset current has exceeded the pre-set value and the action select “Trip and Stop”, it will initiate a trip and stop alarm.
2	Maintenance Due	When count down time is 0 and the action select “Trip and Stop”, it will initiate a trip and stop alarm.
3	Digital Input	When digit input port is set as “Trip and Stop” and the alarm is active, it will initiate a trip and stop alarm.
4	Charge Over Current	When the controller detects that the accumulator current has exceeded the pre-set value and the action select “Trip and Stop”, it will initiate a trip and stop alarm.
5	Charge Over Time	If the charging is not finished within the preset time, and the action select “Trip and Stop”, it will initiate a trip and stop alarm.

6.4 TRIP ALARM

On initiation of the trip condition the controller will de-energize the 'Close Generator' Output without stop the generator.

Trip alarm as following,

No.	Type	Description
1	Gen Over Current	When the controller detects that the genset current has exceeded the pre-set value and the action select "Trip", it will initiate a trip alarm.
2	Digital Input	When digit input port is set as "Trip" and the alarm is active, it will initiate a trip alarm.
3	Charge Over Current	When the controller detects that the accumulator current has exceeded the pre-set value and the action select "Trip", it will initiate a trip alarm.
4	Charge Over Time	If the charging is not finished within the preset time, and the action select "Trip", it will initiate a trip alarm.

7 WIRING CONNECTION

HGM7110DC controller's rear as following:

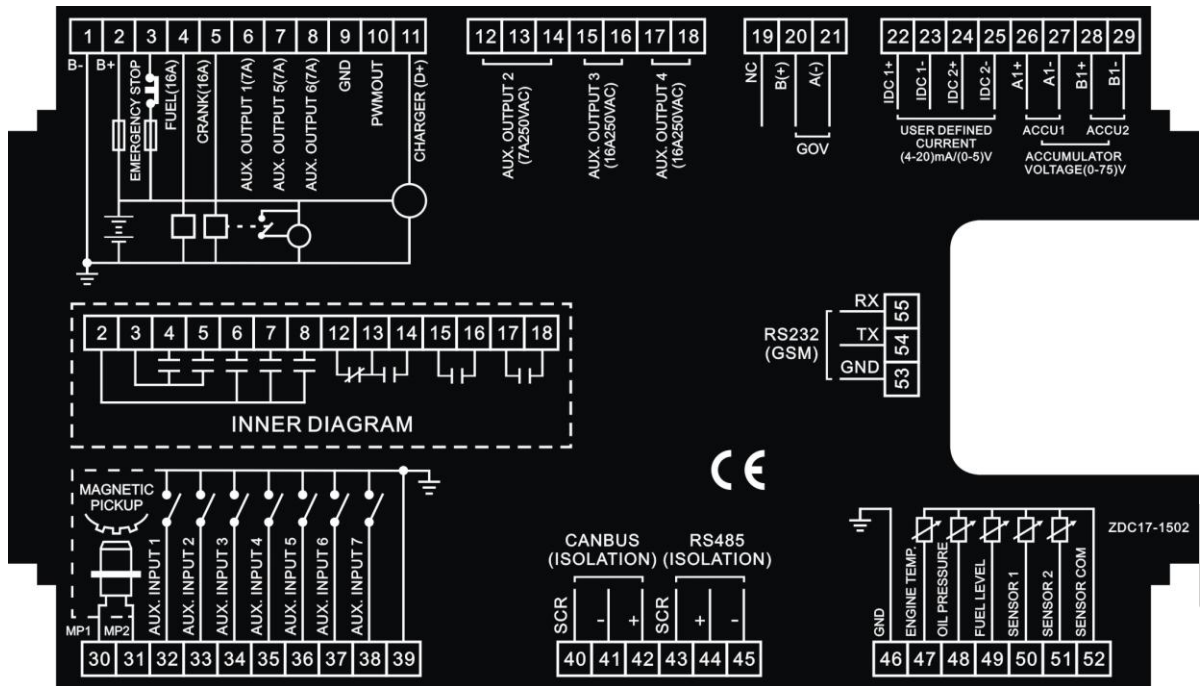

Description of terminal connection:

NO.	Functions	Cable Size	Remark	
1	DC Input -Ve	2.5mm ²	Connected with negative of starter battery.	
2	DC Input +Ve	2.5mm ²	Connected with positive of starter battery. If wire length is over 30m, better to double wires in parallel. Max. 20A fuse is recommended.	
3	Emergency Stop	2.5mm ²	Connected with +Ve via emergency stop button.	
4	Fuel (16A)	1.5mm ²	+Ve is supplied by terminal 3, rated 16A	
5	Crank (16A)	1.5mm ²	+Ve is supplied by terminal 3, rated 16A	Connected to starter coil
6	Aux. Output 1	1.5mm ²	+Ve is supplied by terminal 2, rated 7A	Details see form 2
7	Aux. Output 5	1.5mm ²		
8	Aux. Output 6	1.5mm ²		
9	GND	1.5mm ²	Connect to PWM.	
10	PWMOUT	1.5mm ²		
11	Charger (D+)	1.0mm ²	Connected with charger's D+ (WL) terminals. Be hanging in the air If there is no this terminal.	
12	Aux. Output 2	1.5mm ²	Normally close outputs, rated 7A	Details see form 2
13			Public points of relay	

NO.	Functions	Cable Size	Remark	
14			Normally open outputs, rated 7A	
15	Aux. Output 3	2.5mm ²	Normally open outputs; volts free; rated 16A	
16				
17	Aux. Output 4	2.5mm ²		
18				
19	NC	Reserved		
20	B(+)	1.5mm ²	Connect to GOV or AVR.	
21	A(-)	1.5mm ²		
22	User Config. Current	IDC 1+	1.0mm ²	Connect to (4-20)mA or (0-5)V current transformer.
23		IDC 1-		
24	User Config. Current	IDC 2+	1.0mm ²	Connect to (4-20)mA or (0-5)V current transformer.
25		IDC 2-		
26	A1+	1.0mm ²	1# Accumulator Voltage Input: (0~75V)。	
27	A1-	1.0mm		
28	B1+	1.0mm ²	If "Acc priority" or "Gen priority" is selected, generator voltage will be input; If "Two accs" is selected, generator voltage or 2# accumulator voltage (0-75V) will be input (depends on generator voltage status).	
29	B1-	1.0mm ²		
30	MP1		Connected with Speed sensor, shielding line is recommended.	
31	MP2, (-Ve) has already connected internal			
32	Aux. Input 1	1.0mm ²	Ground connected is active (-Ve)	Details see form 3
33	Aux. Input 2	1.0mm ²	Ground connected is active (-Ve)	
34	Aux. Input 3	1.0mm ²	Ground connected is active (-Ve)	
35	Aux. Input 4	1.0mm ²	Ground connected is active (-Ve)	
36	Aux. Input 5	1.0mm ²	Ground connected is active (-Ve)	
37	Aux. Input 6	1.0mm ²	Ground connected is active (-Ve)	
38	Aux. Input 7	1.0mm ²	Ground connected is active (-Ve)	

NO.	Functions	Cable Size	Remark
39	Aux. Input COM	1.0mm ²	A common terminal of input port, (-Ve) has already connected internal.
40	CANBUS SCR	0.5mm ²	Impedance-120Ω shielding wire is recommended, its single-end earthed. (No CANBUS, no these terminals)
41	CAN-	0.5mm ²	
42	CAN+	0.5mm ²	
43	RS485 SCR	0.5mm ²	Impedance-120Ω shielding wire is recommended, its single-end earthed. (No RS485, no these terminals)
44	RS485+	0.5mm ²	
45	RS485-	0.5mm ²	
46	GND		
47	Engine Temp.	Connect to temperature Sensor.	
48	Oil Pressure	Connect to oil pressure sensor.	
49	Fuel Level	Connect to fuel level sensor.	
50	Config. Sensor 1	Connect to temperature sensor, oil pressure sensor or fuel level sensor.	Details see form 4
51	Config. Sensor 2		
52	Sensor COM	A common terminal of sensor, (-Ve) has <i>NOT</i> connected internal.	
53	RS232(GND)	0.5mm ²	Connected to GSM module.
54	RS232 TX	0.5mm ²	
55	RS232 RX	0.5mm ²	

▲ NOTE: USB ports in controller rear panel are configurable parameter ports, user can directly program controller via PC.

▲ NOTE: If 1# accumulator/2# accumulator temperatures need to be detected, Configured sensor 1/ sensor 2 should be set as “Temperature Sensor”.

8 SCOPES AND DEFINITIONS OF PROGRAMMABLE PARAMETERS

8.1 CONTENTS AND SCOPES OF PARAMETERS

Form 1

No.	Items	Parameters	Defaults	Description
Charge Setting				
1	Acc. 1# Rated Voltage	(0-75) V	48	The rated voltage of 1#accumulator.
2	1# Cell Count	(1-50)	24	The battery number of 1#accumulator.
3	1# Under Voltage Warn	(0-1)	0	0: Disable; 1: Enable
		(0-1000) %	95	Set Value
		(0-1000) %	98	Return Value
		(0-3600) s	5	Delay
4	1# Over Voltage Warn	(0-1)	0	0: Disable; 1: Enable
		(0-1000) %	115	Set Value
		(0-1000) %	112	Return Value
		(0-3600) s	5	Delay
5	1# Under Voltage Stop	(0-1)	0	0: Disable; 1: Enable
		(0-1000) %	92	Set Value
		(0-3600) s	5	Delay
6	1# Over Voltage Stop	(0-1)	0	0: Disable; 1: Enable
		(0-1000) %	118	Set Value
		(0-3600) s	5	Delay
7	Acc. 2# Rated Voltage	(0-75) V	48	The rated voltage of 2#accumulator.
8	1# Cell Count	(1-50)	24	The battery number of 2#accumulator.
9	2# Under Voltage Warn	(0-1)	0	0: Disable; 1: Enable
		(0-1000) %	95	Set Value
		(0-1000) %	98	Return Value
		(0-3600) s	5	Delay
10	2# Over Voltage Warn	(0-1)	0	0: Disable; 1: Enable
		(0-1000) %	115	Set Value
		(0-1000) %	112	Return Value

No.	Items	Parameters	Defaults	Description
		(0-3600) s	5	Delay
11	2# Under Voltage Stop	(0-1)	0	0: Disable; 1: Enable
		(0-1000) %	92	Set Value
		(0-3600) s	5	Delay
12	2# Over Voltage Stop	(0-1)	0	0: Disable; 1: Enable
		(0-1000) %	118	Set Value
		(0-3600) s	5	Delay
13	Temperature Coefficient	(2-5)mV/°C	4	Used for calculating the accumulator voltage after the compensation: $V_{tc} = V_n - T_c \cdot N \cdot (T - 20)$. V_{tc} : Accumulator voltage after the compensation; V_n : Accumulator voltage before the compensation; T_c : Compensation Coefficient; N : Cell Count; T : Temperature Value;
14	Charge Start Volt	(0-1000) %	97	Set Value
		(0-3600) s	5	Delay
15	Charge Stop Volt	(0-1000) %	112	Set Value
		(0-3600) s	5	Delay
16	Charge Stop Mode	(0-2)	0	0: Charge Current + Volt; 1: Charge Delay
17	Constant Charge Volt	(0-1000) %	110	The accumulator charging mode is "Constant Voltage" if the charging voltage after the compensation has reached the set value.
18	Con-Curr. Charge Current	(0-200)A	50	The charging current during "Constant Current Mode".
19	Constant Charge Time	(0-300)h	8	In Auto mode, choose "Charge Delay" as its "Charge Stop Mode". If the genset enters into the "Constant Voltage mode", it will stop after the charge delay has expired.
20	Charge Stop Current	(0-1000) %	40	In Auto mode, choose "Charge Current + Voltage" as its "Charge Stop

No.	Items	Parameters	Defaults	Description
				Mode". If the genset enters into the "Constant Voltage mode", the accumulator charges the genset with its set value as soon as the charge current has fallen below the set value. The charging is finished if the charging voltage has reached the "Charge Stop Voltage".
21	Float Voltage	(0-1000) %	80	Reserved
22	Nominal Voltage	(0-1000) %	100	It's the load voltage if the "Gen Priority" is selected.
23	Charge OC	(0-1)	0	0: Disable; 1: Enable
		(0-200)%	120	Charging Over Current Percentage
		(0-3)	0	0: Warn; 1: Shutdown; 2: Trip and Stop; 3: Trip
		(0-3600)s	10	Charging Over Current Delay
24	Charge increment	(0-10) A	1	Adjust the charge increment manually in Manual mode.
25	Charge Rest Time	(0-1)	0	0: Enable; 1: Disable
		(0-300)h	30	In Auto mode, it is the waiting time before second charging.
26	Charge Limit Time	(0-1)	0	0: Enable; 1: Disable
		(0-3)	0	0: Warn; 1: Shutdown; 2: Trip and Stop; 3: Trip
		(0-300)h	1	After the module is start successfully, if the charging is not finished after the set delay has expired, "Charge Limit Time" alarm will be initiated.
27	System Mode	(0-2)	0	0: Accumulator Priority 1: Gen Priority 2: Double Accumulator Priority
28	Two Accumulators Transfer Mode	(0-1)	0	0: Gap Power Supply 1:Uninterrupted Power Supply
29	Control Mode	(0-2)	0	0:GOV; 1:PWM; 2:AVR
30	GOV Volt. Min.	(0-10.0)V	0	GOV output minimum voltage

No.	Items	Parameters	Defaults	Description
31	GOV Volt. Max.	(0-10.0)V	2.0	GOV output maximum voltage
32	GOV Interface Type	(0-1)	0	0: Normal Output; 1:Reversed Output
33	GOV Gain	(0-500%)	20	GOV Control
34	GOV Stability	(0-2000%)	20	GOV Control
35	GOV Kd	(0-2000)	0	GOV Control
36	AVR Volt. Min.	(0-10.0)V	0	AVR output minimum voltage
37	AVR Volt. Max.	(0-10.0)V	2.0	AVR output maximum voltage
38	AVR Interface Type	(0-1)	0	0: Normal Output; 1:Reversed Output
39	AVR Gain	(0-500%)	20	AVR Control
40	AVR Stability	(0-2000%)	20	AVR Control
41	AVR Kd	(0-2000)	0	AVR Control
42	PWM Gain	(0-100%)	20	PWM Control
43	PWM Stability	(0-100%)	20	PWM Control
44	PWM Kd	(0-100)	0	PWM Control
Timer Setting				
1	Start Delay	(0-3600)s	1	Time from accumulator voltage has fallen below the "Charge Start Voltage" or remote start signal is active to start genset.
2	Stop Delay	(0-3600)s	1	Time from accumulator charging is finished or remote start signal is inactive to stop genset.
3	Preheat Delay	(0-3600)s	0	Time of pre-powering heat plug before starter is powered up.
4	Cranking Time	(3-60)s	8	Time of starter power on
5	Crank Rest Time	(3-60)s	10	The waiting time before second power up when engine start fail.
6	Safety Delay On	(1-60)s	10	Alarms for low oil pressure, high temperature, under speed, under frequency /voltage, charge fail are inactive.
9	Cooling Time	(0-3600)s	10	Radiating time before genset stop, after it unloads.

No.	Items	Parameters	Defaults	Description
12	Fail to Stop Delay	(0-3600)s	20	Time between ending of cooling delay and stopped.
13	After Stop Time	(0-3600)s	0	Time between genset stopped and standby.
Engine Setting				
1	Engine Type	(0-39)	0	Default: Conventional Engine(not J1939) When connected to J1939 engine, choose the corresponding type.
2	Flywheel Teeth	(10-300)	118	Tooth number of the engine, for judging of starter separation conditions and inspecting of engine speed. See the installation instructions.
3	Rated Speed	(0-6000)RPM	1500	Offer standard to judge over/under/loading speed.
4	Loading Speed	(0-100)%	90	Setting value is percentage of rated speed. Controller detects when it is ready to load. It won't enter into "Constant Charging Mode" when speed is under loading speed.
5	Loss of Speed Signal	(0-3600)s	5	Time from detecting speed is 0 to confirm the action.
6	Loss of Speed Signal Action	(0-1)	0	0:Warn; 1:Shutdown
7	Over Speed Shutdown	(0-200)%	114	Setting value is percentage of rated speed and delay value can be set.
8	Under Speed Shutdown	(0-200)%	80	
9	Over Speed Warn	(0-200)%	110	Setting value is percentage of rated speed, delay value and return value can be set.
10	Under Speed Warn	(0-200)%	86	
11	Battery Rated Voltage	(0-60.0)V	24.0	Standard for detecting of over/under voltage of battery.
12	Battery Over Volts	(0-200)%	120	Setting value is percentage of rated voltage of battery; delay value and return value can be set.
13	Battery Under Volts	(0-200)%	85	
14	Charge Alt Fail	(0-60.0)V	8.0	In normal running, when charger

No.	Items	Parameters	Defaults	Description
				D+(WL) voltage under this value, charge failure alarm will be initiated.
15	Start Attempts	(1-10) Times	3	Max. Crank times of crank attempts. When reach this number, failure alarm will be initiated.
16	Crank Disconnect	(0-2)	0	See form 5 There are 2 conditions of disconnecting starter with engine. Each condition can be used alone and simultaneously to separating the start motor and genset as soon as possible.
18	Disconnect Engine Speed	(0-200)%	24	Setting value is percentage of rated speed. When generator speed higher than the set value, starter will be disconnected. See the installation instruction.
19	Disconnect Oil Pressure	(0-1000)kPa	200	When generator oil pressure higher than the set value, starter will be disconnected. See the installation instruction.
Load Setting				
1	Rated Current	(5-6000) A	500	Rated load current
2	Over Current Enable	(0-1)	1	0: Disable 1: Enable
3	Over Current	(0-200) %	120	
4	Over Current Action	(0-3)	0	0: Warn; 1: Shutdown; 2: Trip and Stop; 3: Trip
5	Over Current Type	(0-1)	0	
6	Type 1 (Delay)	(0-3600) s	10	
7	Type 2 (Multiply)	(1-36)	36	
8	Current Input Mode	(0-2)	0	0: 1-lacc 2-lload; 1: 1-lgen 2-lload; 2: 1-lgen 2-lacc.
9	Current Curve Type	(0-1)	0	0: 4-20mA 1: 0-5V
10~25	Current Curve Contents	X(0-32762)m/V Y(0-32767)A	0 0	Custom (x0,y0),(x1,y1),

No.	Items	Parameters	Defaults	Description
26	Current Curve Type	2 (0-1)	0	0: 4-20mA 1: 0-5V
27~42	Current Curve Contents	2 X(0-32762)mA/V Y(0-32767)A	0 0	Custom (x0,y0),(x1,y1)
Switch Setting				
1	Close Time	(0-20.0)s	5.0	
2	Open Time	(0-20.0)s	3.0	
3	Check Time	(0-20.0)s	5.0	
4	Open Check Enable	(0-1)	0	0: Disable ;1: Enable
5	Check Fail Warn	(0-1)	0	0: Disable ;1: Enable
Module Setting				
1	Power Mode	On (0-2)	0	0: Stop mode 1: Manual mode 2: Auto mode
2	Module Address	(1-254)	1	Controller's address during remote sensing.
3	Stop Bits	(0-1)	0	0: 2 stop bits; 1: 1 stop bit
4	Language	(0-2)	0	0: Simplified Chinese 1: English 2: Others
5	Password	(0-65535)	00318	For entering advanced parameters setting.
GSM Setting				
1	GSM Enable	(0-1)	0	0: Disable; 1: Enable
2	Phone Number	Max.20 digits		Its national and area's cods must be added. e.g. China: 8613666666666.
Scheduling And Maintenance Setting				
1	Scheduled Run	(0-1)	0	0: Disable; 1: Enable
2	Scheduled Not Run	(0-1)	0	0: Disable; 1: Enable
3	Maintenance	(0-1)	0	0: Disable; 1: Enable
Analog Sensors Setting				
Temperature Sensor				
1	Curve Type	(0-15)	7	SGX See form 5.

No.	Items	Parameters	Defaults	Description
2	Open Circuit Action	(0-2)	0	0: Warn; 1: Shutdown; 2: No action
3	High Temp. Shutdown	(-50-+300)°C	98	Shutdown when sensor temperature higher than this value. Detecting only after safety delay is over. The delay value can be set.
4	High Temp. Warn	(-50-+300)°C	95	Warn when sensor temperature higher than this value. Detecting only after safety delay is over. The delay value and return value can be set.
5	Low Temp. Warn	(0-1)	0	0: Disable; 1: Enable
Oil Pressure Sensor				
1	Curve Type	(0-15)	7	SGX See form 5.
2	Open Circuit Action	(0-2)	0	0: Warn 1: Shutdown 2: No action
3	Low OP Shutdown	(0-1000)kPa	103	Shutdown when oil pressure lower than this value. Detecting only after safety delay is over. The delay value can be set.
4	Low OP Warn	(0-1000)kPa	124	Warn when oil pressure higher than this value. Detecting only after safety delay is over. The delay value and return value can be set.
Liquid Level Sensor				
1	Curve Type	(0-15)	4	SGH. See form 5
2	Open Circuit Action	(0-2)	0	0:Warn; 1:Shutdown; 2:No action
3	Low Level Warn	(0-300)%	10	Warn when level lower than this value. It is detecting all the time. The delay value and return value can be set.
Configure Sensor 1				
1	Configure Sensor 1 Setting	(0-1)	0	0: Disable 1: Enable; (can be set as temperature/pressure/liquid level sensor).
Configure Sensor 2				
1	Configure Sensor 2 Setting	(0-1)	0	0: Disable; 1: Enable; (can be set as temperature/pressure/liquid level sensor).

No.	Items	Parameters	Defaults	Description
Configure Input Ports				
Configure Input 1				
1	Contents Setting	(0-50)	28	Remote start (on load). See form 3
2	Active Type	(0-1)	0	0: Closed to active 1: Open to active
Configure Input 2				
1	Contents Setting	(0-50)	26	High temperature shutdown See form 3
2	Active Type	(0-1)	0	0: Closed to active 1: Open to active
Configure Input 3				
1	Contents Setting	(0-50)	27	Low oil pressure shutdown See form 3
2	Active Type	(0-1)	0	0: Closed to active 1: Open to active
Configure Input 4				
1	Contents Setting	(0-50)	0	User defined. See form 3
2	Active Type	(0-1)	0	0: Closed to active 1: Open to active
3	Arming	(0-3)	2	0: From safety on 1: From starting 2: Always 3:Never
4	Active Actions	(0-4)	0	0: Warn; 1: Shutdown; 2:Trip and stop 3:Trip 4: Indication
5	Active Delay	(0-20.0)s	2.0	Time from detecting active to confirm
6	Description			LCD display detailed contents when the input is active.
Configure Input 5				
1	Contents Setting	(0-50)	0	User defined .See form 3
2	Active Type	(0-1)	0	0: Closed to active 1: Open to active
3	Arming	(0-3)	2	0: From safety on 1: From starting 2: Always 3:Never
4	Active Actions	(0-4)	1	0: Warn; 1: Shutdown; 2:Trip and stop 3:Trip 4: Indication
5	Active Delay	(0-20.0)s	2.0	Time from detecting active to confirm

No.	Items	Parameters	Defaults	Description
6	Description			LCD display detailed contents when the input is active.
Configure Input 6				
1	Contents Setting	(0-50)	0	User defined .See form 3
2	Active Type	(0-1)	0	0: Closed to active 1: Open to active
3	Arming	(0-3)	2	0: From safety on 1: From starting 2: Always 3:Never
4	Active Actions	(0-4)	2	0: Warn; 1: Shutdown; 2:Trip and stop 3:Trip 4: Indication
5	Active Delay	(0-20.0)s	2.0	Time from detecting active to confirm
6	Description			LCD display detailed contents when the input is active.
Configure Input 7				
1	Contents Setting	(0-50)	5	Lamp test. See form 3
2	Active Type	(0-1)	0	0: Closed to active 1: Open to active
Configure Output Ports				
Configure Output 1				
1	Contents Setting	(0-239)	1	Reserved See Form 4
2	Active Type	(0-1)	0	0:Normally open; 1:Normally close
Configure Output 2				
1	Contents Setting	(0-239)	35	Reserved See Form 4
2	Active Type	(0-1)	0	0:Normally open; 1:Normally close
Configure Output 3				
1	Contents Setting	(0-239)	29	Generator closed output. See Form 4
2	Active Type	(0-1)	0	0:Normally open; 1:Normally close
Configure Output 4				
1	Contents Setting	(0-239)	31	Reserved See Form 4
2	Active Type	(0-1)	0	0:Normally open; 1:Normally close
Configure Output 5				

No.	Items	Parameters	Defaults	Description
1	Contents Setting	(0-239)	38	Reserved See Form 4
2	Active Type	(0-1)	0	0:Normally open; 1:Normally close
Configure Output 6				
1	Contents Setting	(0-239)	48	Common alarm. See Form 4
2	Active Type	(0-1)	0	0:Normally open; 1:Normally close

SmartGen

8.2 PROGRAMMABLE OUTPUT PORTS

Form 2

No.	Type	Description
0	Not Used	
1	Reserved	Details of function description please see the following.
2	Reserved	
3	Reserved	
4	Reserved	
5	Reserved	
6	Reserved	
7	Custom Combined 1	
8	Custom Combined 2	
9	Custom Combined 3	
10	Custom Combined 4	
11	Custom Combined 5	
12	Custom Combined 6	
13	Reserved	
14	Reserved	
15	Reserved	
16	Reserved	
17	Air Flap Control	Action when over speed shutdown and emergence stop. It can close the air inflow to stop the engine as soon as possible.
18	Audible Alarm	Action when warning, shutdown, trips. Can be connected annunciator externally. When "alarm mute" configurable input port is active, it can remove the alarm.
19	Louver Control	Action when genset start and disconnect when genset stopped completely.
20	Fuel Pump Control	It is controlled by limited threshold of fuel pump.
21	Heater Control	It is controlled by limited threshold of heater.
22	Cooler Control	It is controlled by limited threshold of cooler.
23	Oil Pre-supply Output	Action from "crank on" to "safety on".
24	Reserved	
25	Pre-Lubricate	Actions in period of pre-heating to safety run.
26	Remote Control Output	This port is controlled by communication (PC).
27	GSM Power Supply	Power for GSM module (GSM module is reset when GSM communication failed).
28	Reserved	
29	Close Gen Output	Control generator to take load.

30	Open Gen Output	Control generator to off load.
31	1#Acc Load Close	Two Accs; Control 1# accumulator to take load.
32	1#Acc Load Open	Two Accs; Control 1# accumulator to off load.
33	Start Relay	
34	Fuel Relay	Action when genset start and disconnect when genset stop completely.
35	Reserved	
36		
37		
38		
39		
40	ECU Stop	Used for ECU engine and control its stop.
41	ECU Power	Used for ECU engine and control its power.
42	Reserved	
43	Crank Success	Close when detects a successful start signal.
44	Reserved	
45	Reserved	
46		
47		
48	Common Alarm	Action when genset common warning, common shutdown, common trips alarm.
49	Common Trip and Stop	Action when common trip and stop alarm.
50	Common Shutdown	Action when common shutdown alarm.
51	Common Trip Alarm	Action when common trips alarm.
52	Common Warn Alarm	Action in common warning alarm.
53	Reserved	
54	Battery High Volts	Action when battery's over voltage warning alarm.
55	Battery Low Volts	Action when battery's low voltage warning alarm.
56	Charge Alt Fail	Action when charge failure warning alarms.
57	1#Acc Charge Close	Control 1# accumulator charge switch to close.
58	1#Acc Charge Open	Control 1# accumulator charge switch to open.
59	Measuring Gen Volts	Two accumulator system detect the Gen voltage or 2# Accumulator Voltage effectively.
60	ECU Warn	Indicate ECU sends a warning signal.
61	ECU Shutdown	Indicate ECU sends a shutdown signal.
62	ECU Com Fail	Indicate controller not communicates with ECU.
63	2#Acc Charge Close	Control 2# accumulator charge switch to close.
64	2#Acc Charge Open	Control 2# accumulator charge switch to open.
65	1# Acc. Over Voltage Warn	
66	1# Acc. Under Voltage	

	Warn	
67	1# Acc. Over Voltage Shutdown	
68	1# Acc. Under Voltage Shutdown	
69	Aux Input 1 Active	Action when input port 1 is active
70	Aux Input 2 Active	Action when input port 2 is active
71	Aux Input 3 Active	Action when input port 3 is active
72	Aux Input 4 Active	Action when input port 4 is active
73	Aux Input 5 Active	Action when input port 5 is active
74	Aux Input 6 Active	Action when input port 6 is active
75	Aux Input 7 Active	Action when input port 7 is active
76~98	Reserved	
99	Emergency Stop	Action when emergency stop alarm.
100	Failed To Start	Action when failed start alarm.
101	Failed To Stop	Action when failed stop alarm.
102	Under Speed Warn	Action when under speed alarm.
103	Under Speed Shutdown	Action when under speed shuts down.
104	Over Speed Warn	Action when over speed warn.
105	Over Speed Shutdown	Action when over speed shutdown alarm.
106	2#Acc Load Close	Two Accs: Control 2# accumulator to take load.
107	2#Acc Load Open	Two Accs: Control 2# accumulator to off load.
108~122	Reserved	
123	Over Current	Action when over current.
124~133	Reserved	
134	2#Acc. Overvolts Warn	
135	2#Acc. UndervoltsWarn	
136	2#Acc. Overvolts Shutdown	
137	2#Acc. Undervolts Shutdown	
138	Reserved	
139	High Temp Warn	Action when hi-temperature warning.
140	Low Temp Warn	Action when low temperature warning.
141	High Temp Shutdown	Action when hi-temperature shutdown alarm.
142	Reserved	
143	Low OP Warn	Action when low oil pressure warning.
144	Low OP Shutdown	Action when low oil pressure shutdown.
145	OP Sensor Open	Action when oil pressure sensor is open circuit.
146	Reserved	
147	Low Level Warn	Action when controller has low oil level alarm.

148	Reserved	
149	Reserved	
150	Config1 High Warn	
151	Config1 Low Warn	
152	Config1 High Shutdown	
153	Config1 Low Shutdown	
154	Config2 High Warn	
155	Config2 Low Warn	
156	Config2 High Shutdown	
157	Config2 Low Shutdown	
158~229	Reserved	
230	Stop Mode	Action in stop mode.
231	Manual Mode	Action in Manual mode.
232	Reserved	
233	Auto Mode	Action in Auto mode.
234	Generator On Load	
235	Reserved	
236	Reserved	
237	Reserved	
238	Reserved	
239	Reserved	

8.2.1 DEFINED COMBINATION OUTPUT

Defined combination output is composed by 3 parts, condition output S1 or S2 and condition output S3.

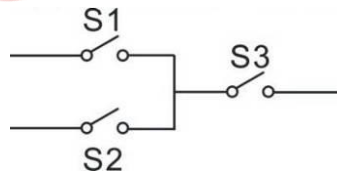

S1 or S2 is **TRUE**, while S3 is **TRUE**, Defined combination output is outputting;

S1 and S2 are **FALSE**, or S3 is **FALSE**, Defined combination output is not outputting.

▲NOTE: S1, S2, S3 can be set as any item except for “defined combination output” which is given in the section entitled *Programmable Output Ports* elsewhere in this manual.

▲NOTE: 3 parts of defined combination output (S1, S2, S3) couldn't include or recursively include themselves.

Example,

Contents of condition output S1: output port 1 is active;

Close when condition output S1 is active /inactive: close when active (disconnect when inactive);

Contents of condition output S2: output port 2 is active;

Close when condition output S2 is active /inactive: close when active (disconnect when inactive);

Contents of condition output S3: output port 3 is active;

Close when condition output S3 is active /inactive: close when active (disconnect when inactive);





When input port 1 active or input port 2 active, if input port 3 is active, Defined Combination Output is outputting; If input port 3 inactive, Defined Combination Output is not outputting;







When input port 1 inactive and moreover, input port 2 inactive, whatever input port 3 is active or not, Defined Combination Output is not outputting.

SmartGen

8.3 PROGRAMMABLE INPUT PORTS (ALL ACTIVE WHEN CONNECT TO GRAND (B-))

Form 3

No.	Type	Description
0	Users Configured	Including following functions, Indication: indicate only, not warning or shutdown. Warning: warn only, not shutdown. Shutdown: alarm and shutdown immediately Trip and stop: alarm, generator unloads and shutdown after hi-speed cooling Trip: alarm, generator unloads but not shutdown. Never: input inactive. Always: input is active all the time. From crank: detecting from generator start. From safety on: detecting after safety on delay.
1	Reserved	
2	Alarm Mute	Can prohibit "Audible Alarm" output when input is active.
3	Reset Alarm	Can reset shutdown alarm and trip alarm when input is active.
4	Reserved	
5	Lamp Test	All LED indicators are illuminating when input is active.
6	Panel Lock	All buttons in panel is inactive except    and there is  in the right of first row in LCD when input is active.
7	Reserved	
8		
9	Inhibit Auto Stop	In Auto mode, during generator normal running, when input is active, prohibit generator shutdown automatically.
10	Inhibit Auto Start	In Auto mode, prohibit generator start automatically when input is active.
11	Inhibit Scheduled	In Auto mode, prohibit fixed timing start genset when input is active.
12	Reserved	
13	Aux Gen Closed	Connect generator loading switch's auxiliary point.
14	Inhibit Gen Load	Prohibit genset switch on when input is active.
15	1#Acc.Load Closed	Connect to the load switch's auxiliary point of 1# Accumulator.
16	2#Acc.Load Closed	Connect to the load switch's auxiliary point of 2#

		Accumulator.
17	Auto Mode Lock	When input is active, controller enters into Auto Mode; all the keys except     are inactive and there is  in the right of first row in LCD.
18	Auto Mode Invalid	When input is active, controller won't work under Auto Mode.  key and simulate auto key input does not work.
19	Reserved	
20	Reserved	
21	Inhibit Alarm Stop	All shutdown alarms are prohibited except emergence stop.(i.e. battle mode or override mode)
22	Aux Instrument Mode	All outputs are prohibited in this mode.
23	Reserved	
24	Reset Maintenance	Controller will set maintenance time and date as default when input is active.
25	Reserved	
26	Aux. High Temp	Connect to sensor digital input.
27	Aux. Low OP	Connect to sensor digital input.
28	Remote Start (On Load)	In Auto mode, when input is active, can start genset automatically and with load when genset is normal running; when input is inactive, can stop genset automatically.
29	Reserved	
30	Aux. Manual Start	In Manual mode, when input is active, can start genset automatically; when input is inactive, can stop genset automatically.
31	1#Acc.Charge Closed	Connect to the auxiliary point of 1# accumulator.
32	2#Acc.Charge Closed	Connect to the auxiliary point of 2# accumulator.
33	Simulate Stop key	An external button; can be connected to simulate panel button.
34	Simulate Manual key	
35	Reserved	
36	Simulate Auto key	
37	Simulate Start key	
38	Simulate Gen Load key	
39	Reserved	
40	Reserved	
41	Reserved	
42	Reserved	
43	Simulate Raise Key	An external button; can be connected to simulate panel

44	Simulate Drop Key	button.
45	Reserved	
46	Reserved	
47	Reserved	
48	Reserved	
49	Reserved	
50	Reserved	

SmartGen

8.4 SELECTION OF SENSORS

Form4

No.	Items	Description	Remark
1	Temperature Sensor	0 Not used 1 Custom Res Curve 2 Custom 4-20mA curve 3 VDO 4 CURTIS 5 VOLVO-EC 6 DATCON 7 SGX 8 SGD 9 SGH 10 PT100 11~14 Reserved 15 Custom 0~5V Curve	Defined resistance's range is (0~6)KΩ, default is SGX sensor.
2	Pressure Sensor	0 Not used 1 Custom Res Curve 2 Custom 4-20mA curve 3 VDO 10Bar 4 CURTIS 5 VOLVO-EC 6 DATCON 10Bar 7 SGX 8 SGD 9 SGH 10~14 Reserved 15 Custom 0~5V Curve	Defined resistance's range is (0~6)KΩ, default is SGX sensor.
3	Fuel Level Sensor	0 Not used 1 Custom Res Curve 2 Custom 4-20mA Curve 3 SGD 4 SGH 5~14 Reserved 15 Custom 0~5V Curve	Defined resistance's range is (0~6)KΩ, default is SGH sensor.

NOTE: User should make special declare when order controller if your genset equip with 4~20mA sensor or 0~5V sensor.

8.5 CONDITIONS OF CRANK DINSCONNECT SELECTION

No.	Setting Description
1	Engine Speed
2	Oil pressure
3	Oil pressure + Engine Speed

NOTE:

- 1) There are 2 conditions to make starter disconnected with engine, that is, engine speed, and oil pressure. Both of them can be used separately. We recommend that oil pressure should be using with speed sensor together, in order to make the starter separate with engine as soon as possible and can check start exactly.
- 2) Speed sensor is the magnetic equipment which be installed in starter for detecting flywheel teeth.
- 3) When set as engine speed, must ensure that the number of flywheel teeth is as same as setting, otherwise, “over speed stop” or “under speed stop” may be caused.
- 4) If genset without speed sensor, please don't select corresponding items which include *engine speed*, otherwise, “start fail” or “loss of speed signal” maybe caused.
- 5) If genset without oil pressure sensor, please don't select corresponding items which include *oil pressure*.

 CAUTION: Please change the controller parameters when generator is in standby mode only (e. g. Crank disconnect conditions selection, configurable input, configurable output, various delay), otherwise, shutdown alarm or other abnormal conditions may occur.

 NOTE: Maximum set value must greater than minimum set value in case that the condition of too high as well as too low may occur.

 NOTE: When setting the warning alarm, please set the correct return value; otherwise, maybe abnormal alarm occurs. When setting the maximum value, the return value must less than set value; When setting the minimum value, the return value must greater than set value.

 NOTE: Configurable input ports could not be set as same items; otherwise, abnormal functions occur. However, the configurable output ports can be set as same items.

9 SENSORS SETTING

- 1) When reselect sensors, the sensor curve will be transferred into the standard value. For example, if default temperature sensor is SGX (120°C resistor type), its sensor curve is SGX (120°C resistor type); if select the SGD (120°C resistor type), the temperature sensor curve is SGD curve.
- 2) When there is difference between standard sensor curves and using one, user can adjust it in “curve type”.
- 3) When input the sensor curve, X value (resistor) must be input from small to large, otherwise, mistake occurs.
- 4) If select sensor type as “None”, sensor curve is not working.
- 5) If corresponding sensor has alarm switch only, user must set this sensor as “None”, otherwise, shutdown or warning alarm occurs.
- 6) The headmost or backmost values in the vertical coordinates can be set as the same one, as shown below,

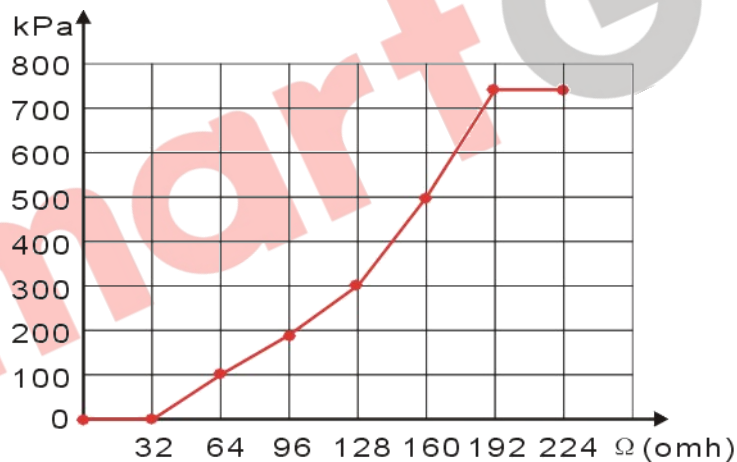

Normal Pressure Unit Conversion Form

	pa	kgf/cm ²	bar	psi
1Pa	1	1.02x10 ⁻⁵	1x10 ⁻⁵	1.45x10 ⁻⁴
1kgf/cm ²	9.8x10 ⁴	1	0.98	14.2
1bar	1x10 ⁵	1.02	1	14.5
1psi	6.89x10 ³	7.03x10 ⁻²	6.89x10 ⁻²	1

10 COMMISSIONING

Please make the under procedures checking before commissioning,

1. Ensure all the connections are correct and wires diameter is suitable.
2. Ensure that the controller DC power has fuse, controller's positive and negative connected to start battery are correct.
3. Emergence stop must be connected with positive of start battery via scram button's normal close point and fuse.
4. Take proper action to prevent engine to crank disconnect (e. g. Remove the connection wire of fuel valve). If checking is OK, make the start battery power on; choose manual mode and controller will executive routine.
5. Set controller under manual mode, press "start" button, genset will start. After the setting times as setting, controller will send signal of Start Fail; then press "stop" to reset controller.
6. Recover the action of stop engine start (e. g. Connect wire of fuel valve), press start button again, genset will start. If everything goes well, genset will normal run after idle running (if idle run be set). During this time, please watch for engine's running situations and AC generator's voltage and frequency. If abnormal, stop genset running and check all wires connection according to this manual.
7. If there is any other question, please contact Smartgen's service.

11 TYPICAL APPLICATION

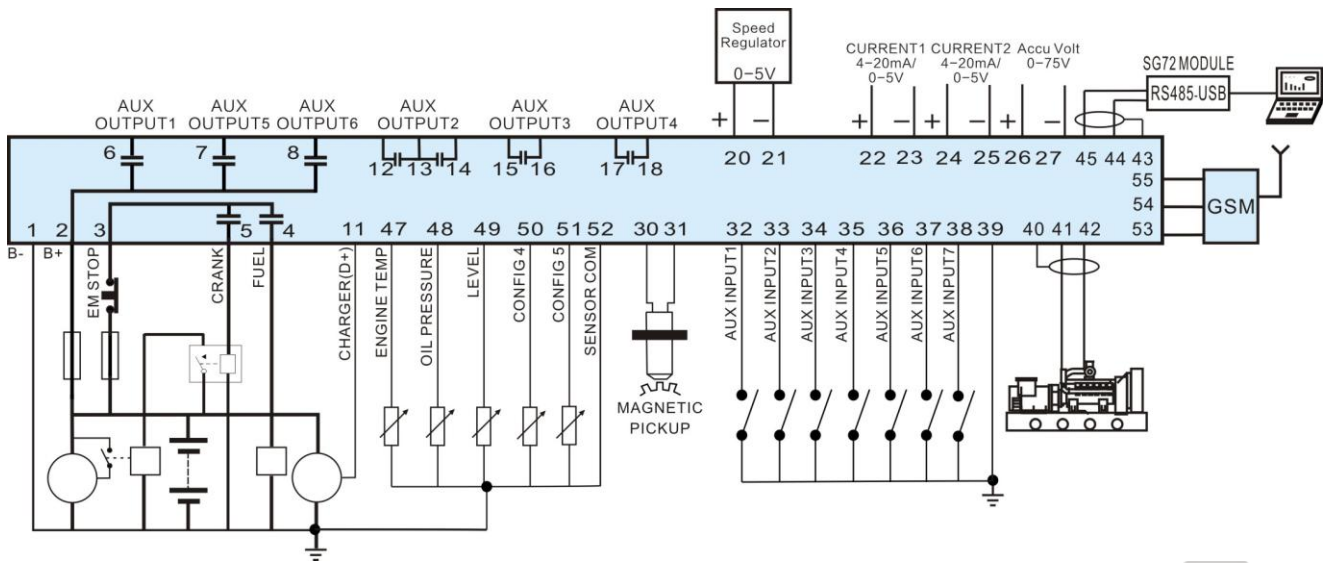

SmartGen

12 INSTALLATION

Controller is panel built-in design; it is fixed by clips when installed. The controller's overall dimensions and cutout dimensions for panel, please refers to as following,

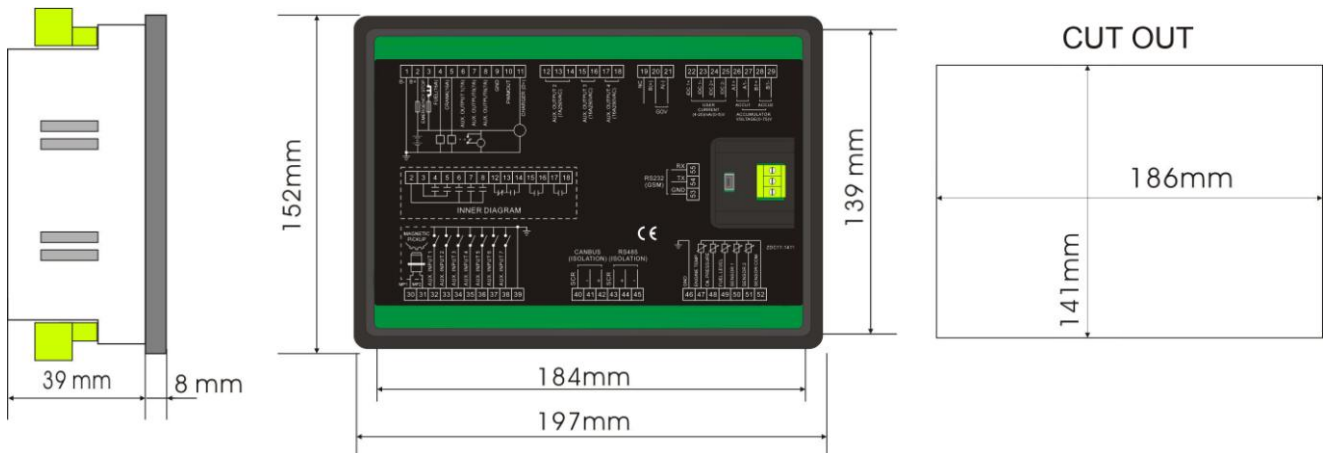

1) Battery Voltage Input

NOTE: HGM7110DC controller can suit for widely range of battery voltage DC(8~35)V. Negative of battery must be connected with the shell of starter. The wire's diameter connect controller and battery must be over 2.5mm^2 . If floating charger configured, please firstly connect output wires of charger to battery's positive and negative directly, then, connect wires from battery's positive and negative to controller's corresponding ports in order to prevent the charger interfere with the normal operation of the controller.

2) Speed Sensor Input

NOTE: Speed sensor is the magnetic equipment which be installed in starter and for detecting flywheel teeth. Its connection wires to controller should apply for 2 cores shielding line. The shielding layer should connect to No. 31 terminal in controller while another side is hanging in air. The else two signal wires are connected to No.30 and No.31 terminals in controller. The output voltage of speed sensor should be within AC (1~24)V (effective value) during the full speed. AC12V is recommended (in rated speed). When install the speed sensor, spun the sensor until only the pointed end is protruding from the flywheel, then, withdraw 1/3 lap, and lock the nuts of the sensor at last.

3) Output And Expand Relays

CAUTION: All outputs of controller are relay contact output. If need to expand the relays, please add freewheel diode to both ends of expand relay's coils (when relay coils has DC current) or, increase resistance-capacitance return circuit (when relay coils has AC current), in order to prevent disturbance to controller or others equipment.

4) Withstand Voltage Test

⚠ CAUTION! When controller had been installed in control panel, if need the high voltage test, please disconnect controller's all terminal connections, in order to prevent high voltage into controller and damage it.

SmartGen

13 GSM SHORT MESSAGE ALARM AND REMOTE CONTROL

13.1 GSM SHORT MESSAGE ALARM

When controller detects alarm, it will send short message to phone automatically.

▲NOTE: All alarms about shutdown, trip and stop and trip will be sent to the pre-set phone.

Warnings are sent to the phone according to the pre-set.

SmartGen

13.2 GSM SHORT MESSAGE REMOTE CONTROL

Users send order message to GSM module, then controller will make actions according to this SMS order and pass back corresponding operations information. Controllers only execute the orders by pre-set. Detail orders as following:

No.	SMS Orders	Pass back Information	Description
1	SMS GENSET	GENSET ALARM	When genset is stopping alarm
		SYSTEM IN STOP MODE GENSET AT REST	At rest status in stop mode
		SYSTEM IN MANUAL MODE GENSET AT REST	At rest status in manual mode
		SYSTEM IN AUTO MODE GENSET AT REST	At rest status in Auto mode
		SYSTEM IN STOP MODE GENSET IS RUNNING	Running status in stop mode
		SYSTEM IN MANUAL MODE GENSET IS RUNNING	Running status in manual mode
		SYSTEM IN AUTO MODE GENSET AT RUNNING	Running status in Auto mode
2	SMS START	GENSET ALARM	Generator is shutdown alarm or trip alarm
		STOP MODE NOT START	Cannot start in stop mode
		SMS START OK	Start in manual mode
		AUTO MODE NOT START	Cannot start in auto mode
3	SMS STOP MODE	SMS STOP OK	Set as stop mode
4	SMS MANUAL MODE	SMS MANUAL MODE OK	Set as manual mode
5	SMS AUTO MODE	SMS AUTO MODE OK	Set as auto mode

6	SMS DETAIL	Pass back information can be set via controller software.	Gets details information of genset.
7	SMS INHIBIT START	INHIBIT START OK	Generator start will be inhibited.
8	SMS PERMIT START	PERMIT START OK	Discharge the inhibit start signal.

▲NOTE: When sending orders, users need to follow SMS orders in above form and all the letters must be capital.

▲NOTE: Pass back information from SMS DETAIL including: working mode.

SmartGen

14 CONNECTIONS OF CONTROLLER WITH J1939 ENGINE

14.1 CUMMINS ISB/ISBE

Terminals of controller	Connector B	Remark
Fuel relay output	39	
Start relay output	-	Connect with starter coil directly
Auxiliary output port 1	Expand 30A relay, battery voltage of 01,07,12,13 is supplied by relay	ECU power Set Auxiliary output 1 as "ECU power"

Terminals of controller	9 pins connector	Remark
CAN GND	SAE J1939 shield	CAN communication shielding line(connect with ECU terminal only)
CAN(H)	SAE J1939 signal	Impedance 120Ω connecting line is recommended.
CAN(L)	SAE J1939 return	Impedance 120Ω connecting line is recommended.

Engine type: Cummins ISB

14.2 CUMMINS QSL9

Suitable for CM850 engine control module

Terminals of controller	50 pins connector	Remark
Fuel relay output	39	
Start relay output	-	Connect to starter coil directly

Terminals of controller	9 pins connector	Remark
CAN GND	SAE J1939 shield-E	CAN communication shielding line(connect with ECU terminal only)
CAN(H)	SAE J1939 signal-C	Impedance 120Ω connecting line is recommended.
CAN(L)	SAE J1939 return-D	Impedance 120Ω connecting line is recommended.

Engine type: Cummins-CM850

14.3 CUMMINS QSM11 (IMPORT)

It is suitable for CM570 engine control module. Engine type is QSM11 G1, QSM11 G2.

Terminals of controller	C1 connector	Remark
Fuel relay output	5&8	Outside expand relay, when fuel output, making port 5 and port 8 of C1 be connected
Start relay output	-	Connect to starter coil directly

Terminals of controller	3 pins data link connector	Remark
CAN GND	C	CAN communication shielding line(connect with ECU terminal only)
CAN(H)	A	Impedance 120Ω connecting line is recommended.
CAN(L)	B	Impedance 120Ω connecting line is recommended.

Engine type: Cummins ISB

14.4 CUMMINS QSX15-CM570

It is suitable for CM570 engine control module. Engine type is QSX15.

Terminals of controller	50 pins connector	Remark
Fuel relay output	38	Oil spout switch
Start relay output	-	Connect to starter coil directly

Terminals of controller	9 pins connector	Remark
CAN GND	SAE J1939 shield-E	CAN communication shielding line(connect with ECU terminal only)
CAN(H)	SAE J1939 signal-C	Impedance 120Ω connecting line is recommended.
CAN(L)	SAE J1939 return-D	Impedance 120Ω connecting line is recommended.

Engine type: Cummins QSX15-CM570

14.5 CUMMINS GCS-MODBUS

It is suitable for GCS engine control module. Use RS485-MODBUS to read information of engine. Engine types are QSX15, QST30, QSK23 / 45/60/78 and so on.

Terminals of controller	D-SUB connector 06	Remark
Fuel relay output	5&8	Outside expand relay, when fuel output, making port 05 and 08 of the connector 06 be connected.
Start relay output	-	Connect to starter coil directly

Terminals of controller	D-SUB connector 06	Remark
RS485 GND	20	CAN communication shielding line(connect with ECU terminal only)
RS485+	21	Impedance 120Ω connecting line is recommended.
RS485-	18	Impedance 120Ω connecting line is recommended.

Engine type: Cummins QSK-MODBUS, Cummins QST-MODBUS, Cummins QSX-MODBUS

14.6 DETROIT DIESEL DDEC III / IV

Terminals of controller	CAN port of engine	Remark
Fuel relay output	Expand 30A relay; battery voltage of ECU is supplied by relay.	
Start relay output	-	Connect to starter coil directly
CAN GND	-	CAN communication shielding line(connect with controller's terminal only)
CAN(H)	CAN(H)	Impedance 120Ω connecting line is recommended.
CAN(L)	CAN(L)	Impedance 120Ω connecting line is recommended.

Engine type: Common J1939

14.7 DEUTZ EMR2

Terminals of controller	F connector	Remark
Fuel relay output	Expand 30A relay; battery voltage of terminal 14 is supplied by relay. Fuse is 16A.	
Start relay output	-	Connect to starter coil directly
-	1	Connect to battery negative pole
CAN GND	-	CAN communication shielding line(connect with controller's terminal only)
CAN(H)	12	Impedance 120Ω connecting line is recommended.
CAN(L)	13	Impedance 120Ω connecting line is recommended.

Engine type: VolvoEDC4

14.8 JOHN DEERE

Terminals of controller	21 pins connector	Remark
Fuel relay output	G,J	
Start relay output	D	
CAN GND	-	CAN communication shielding line(connect with controller's terminal only)
CAN(H)	V	Impedance 120Ω connecting line is recommended.
CAN(L)	U	Impedance 120Ω connecting line is recommended.

Engine type: John Deere

14.9 MTU MDEC

Suitable for MTU engines, 2000 series, 4000series

Terminals of controller	X1 connector	Remark
Fuel relay output	BE1	
Start relay output	BE9	
CAN GND	E	CAN communication shielding line(connect with one terminal only)
CAN(H)	G	Impedance 120Ω connecting line is recommended.
CAN(L)	F	Impedance 120Ω connecting line is recommended.

Engine type: MTU-MDEC-303

14.10 PERKINS

It is suitable for ADEM3/ ADEM4 engine control module. Engine type is 2306, 2506, 1106, and 2806.

Terminals of controller	Connector	Remark
Fuel relay output	1,10,15,33,34	
Start relay output	-	Connect to starter coil directly
CAN GND	-	CAN communication shielding line(connect with controller's terminal only)
CAN(H)	31	Impedance 120Ω connecting line is recommended.
CAN(L)	32	Impedance 120Ω connecting line is recommended.

Engine type: Perkins

14.11 SCANIA

It is suitable for S6 engine control module. Engine type is DC9, DC12, and DC16.

Terminals of controller	B1 connector	Remark
Fuel relay output	3	
Start relay output	-	Connect to starter coil directly
CAN GND	-	CAN communication shielding line(connect with controller's terminal only)
CAN(H)	9	Impedance 120Ω connecting line is recommended.
CAN(L)	10	Impedance 120Ω connecting line is recommended.

Engine type: Scania

14.12 VOLVO EDC3

Suitable engine control mode is TAD1240, TAD1241, and TAD1242.

Terminals of controller	"Stand alone" connector	Remark
Fuel relay output	H	
Start relay output	E	
Auxiliary output 1	P	ECU power Set Auxiliary output 1 as "ECU power"

Terminals of controller	"Data bus" connector	Remark
CAN GND	-	CAN communication shielding line(connect with controller's terminal only)
CAN(H)	1	Impedance 120Ω connecting line is recommended.
CAN(L)	2	Impedance 120Ω connecting line is recommended.

Engine type: Volvo

▲NOTE: When this engine type is selected, preheating time should be set to at least 3 seconds.

14.13 VOLVO EDC4

Suitable engine types are TD520, TAD520 (optional), TD720, TAD720 (optional), TAD721, TAD722, and TAD732.

Terminals of controller	Connector	Remark
Fuel relay output	Expand 30A relay; battery voltage of terminal 14 is supplied by relay. Fuse is 16A.	
Start relay output	-	Connect to starter coil directly
	1	Connected to negative of battery
CAN GND	-	CAN communication shielding line(connect with controller's terminal only)
CAN(H)	12	Impedance 120Ω connecting line is recommended.
CAN(L)	13	Impedance 120Ω connecting line is recommended.

Engine type: VolvoEDC4

14.14 VOLVO-EMS2

Volvo Engine types are TAD734, TAD940, TAD941, TAD1640, TAD1641, and TAD1642.

Terminals of controller	Engine's CAN port	Remark
Auxiliary output 1	6	ECU stop Set Auxiliary output 1 as "ECU Stop"
Auxiliary output 2	5	ECU power Set Auxiliary output 2 as "ECU power"
	3	Negative power
	4	Positive power
CAN GND	-	CAN communication shielding line(connect with controller's terminal only)
CAN(H)	1(Hi)	Impedance 120Ω connecting line is recommended.
CAN(L)	2(Lo)	Impedance 120Ω connecting line is recommended.

Engine type: Volvo-EMS2

▲ NOTE: When this engine type is selected, preheating time should be set to at least 3 seconds.

14.15 BOSCH

It is suitable for BOSCH common rail pump engine.

Terminals of controller	Engine 42 pins port	Remark
Fuel relay output	1.40	Connect to engine ignition lock
Start relay output	-	Connect to starter coil directly
CAN GND	-	CAN communication shielding line(connect with controller's this terminal only)
CAN(H)	1.35	Impedance 120Ω connecting line is recommended.
CAN(L)	1.34	Impedance 120Ω connecting line is recommended.

Battery	Engine 2 pins	Remark
Battery negative	1	Wire diameter 2.5mm ²
Battery positive	2	Wire diameter 2.5mm ²

Engine type: BOSCH

▲ NOTE: If there is any question of connection between controller and ECU communication, please feel free to contact Smartgen's service.

15 FAULT FINDING

Symptoms	Possible Solutions
Controller no response with power.	Check starting batteries; Check controller connection wirings; Check DC fuse.
Genset shutdown	Check the water/cylinder temperature is too high or not; Check the genset AC voltage; Check DC fuse.
Controller emergency stop	Check emergence stop button is correct or not; Check whether the starting battery positive is connected with the emergency stop input; Check whether the circuit is open.
Low oil pressure alarm after crank disconnect	Check the oil pressure sensor and its connections.
High water temp. alarm after crank disconnect	Check the temperature sensor and its connections.
Shutdown Alarm in running	Check related switch and its connections according to the information on LCD; Check programmable inputs.
Crank not disconnect	Check fuel oil circuit and its connections; Check starting batteries; Check speed sensor and its connections; Refer to engine manual.
Starter no response	Check starter connections; Check starting batteries.
Genset running while ATS not transfer	Check ATS; Check the connections between ATS and controllers.
RS485 communication is abnormal	Check connections; Check setting of COM port is correct or not; Check RS485's connections of A and B is reverse connect or not; Check RS485 transfer model whether damage or not; Check communication port of PC whether damage.
ECU communication failed	Check connections of CAN high and low polarity; Check if correctly connected of 120Ω resistor; Check if type of engine correct; Check if connections from controller to engine and output ports setting are correct.
ECU warning or shutdown	Get information from LCD of alarm page; If there is detailed alarm, check engine according to description. If not, please refer to engine manual according to SPN alarm code.