



SmartGen
ideas for power

HGM8110DC
GENSET CONTROLLER
USER MANUAL



SMARTGEN (ZHENGZHOU) TECHNOLOGY CO., LTD.



Chinese trademark

SmartGen English trademark

SmartGen — make your generator *smart*

SmartGen Technology Co., Ltd.

No.28 Jinsuo Road

Zhengzhou

Henan Province

P. R. China

Tel: 0086-371-67988888/67981888

0086-371-67991553/67992951

0086-371-67981000(overseas)

Fax: 0086-371-67992952

Web: www.smartgen.com.cn

www.smartgen.cn

Email: sales@smartgen.cn

All rights reserved. No part of this publication may be reproduced in any material form (including photocopying or storing in any medium by electronic means or other) without the written permission of the copyright holder.

Applications for the copyright holder's written permission to reproduce any part of this publication should be addressed to SmartGen Technology at the address above.

Any reference to trademarked product names used within this publication is owned by their respective companies.



SmartGen Technology reserves the right to change the contents of this document without prior notice.

Table 1 - Software Version

Date	Version	Note
2018-09-15	1.0	Original release.
2018-12-27	1.1	Add controller DC description so as to highlight DC feature.

This manual is suitable for HGM8110DC controller only.

Table 2 - Notation Clarification

Sign	Instruction
 NOTE	Highlights an essential element of a procedure to ensure correctness.
 CAUTION!	Indicates a procedure or practice, which, if not strictly observed, could result in damage or destruction of equipment.
 WARNING!	Indicates a procedure or practice, which could result in injury to personnel or loss of life if not followed correctly.

SmartGen

CONTENTS

1	OVERVIEW	6
2	MOUDLES COMPARISON.....	7
3	PERFORMANCE AND CHARACTERISTICS	8
4	SPECIFICATION OPERATION	10
5	OPERATION	11
5.1	INDICATORS	11
5.2	KEY FUNCTION	11
5.3	LCD DISPLAY.....	12
5.3.1.	MAIN DISPLAY.....	12
5.3.2.	PARARMETERS SETTING MANUAL	14
5.3.3.	PARAMETER SETTINGS	14
5.4	AUTO START/STOP OPERATION.....	15
5.5	MANUAL START/STOP OPERATION.....	16
5.6	GENSET CONTROLLER SWITCH CONTROL PROCEDURES.....	17
5.6.1.	HGM8110DC SWITCH CONTROL PROCEDURES.....	17
5.6.1.1	MANUAL TRANSFER PROCEDURES	17
5.6.1.2	AUTO CONTROL PROCEDURES	17
6	PROTECTION	18
6.1	WARNINGS	18
6.2	SHUTDOWN ALARM	20
6.3	TRIP AND STOP ALARM	22
6.4	TRIP ALARM.....	23
7	WIRINGS CONNECTION.....	24
8	SCOPES AND DEFINITIONS OF PROGRAMMABLE PARAMETERS	27
8.1	CONTENTS AND SCOPES OF PARAMETERS.....	27
8.2	ENABLE DEFINITION OF PROGRAMMABLE OUTPUT PORTS	35
8.2.1.	ENABLE DEFINITION OF PROGRAMMABLE OUTPUT PORTS FORM	35
8.2.2.	CUSTOM PERIOD OUTPUT	41
8.2.3.	CUSTOM COMBINED OUTPUT.....	41
8.3	DEFINED CONTENTS OF CONFIGURABLE INPUT PORTS	42
8.4	SELECTION OF SENSORS.....	44
8.5	CONDITIONS OF CRANK DISCONNECT SELECTION.....	45
9	PARAMETERS SETTING.....	46
10	SENSORS SETTING.....	47
11	COMMISSIONING	48
12	TYPICAL APPLICATION.....	49
13	INSTALLATION	50
13.1	OVERALL DIMENSION	50
13.2	BATTERY VOLTAGE INPUT	50
13.3	SPEED SENSOR INPUT.....	50
13.4	OUTPUT AND EXPAND RELAYS	50
13.5	AC INPUT	51

13.6	WITHSTAND VOLTAGE TEST	51
14	CONNECTIONS OF CONTROLLER WITH J1939 ENGINE	52
14.1	CUMMINS ISB/ISBE.....	52
14.2	CUMMINS QSL9.....	52
14.3	CUMMINS QSM11(import)	52
14.4	CUMMINS QSX15-CM570	53
14.5	CUMMINS GCS-MOVBUS.....	53
14.6	CUMMINS QSM11	54
14.7	CUMMINS QSZ13	54
14.8	DETROIT DIESEL DDEC III / IV.....	54
14.9	DEUTZ EMR2.....	55
14.10	JOHN DEERE.....	55
14.11	MTU MDEC.....	55
14.12	MTU ADEC(SMART MODULE).....	56
14.13	MTU ADEC (SAM MODULE)	56
14.14	PERKINS	56
14.15	SCANIA	57
14.16	VOLVO EDC3.....	57
14.17	VOLVO EDC4.....	57
14.18	VOLVO-EMS2.....	58
14.19	YUCHAI	58
14.20	WEICHAH	58
15	ETHERNET INTERFACE	59
15.1	ETHERNET INTERFACE INTRODUCTION	59
15.2	NETWORK CLIENT CONNECTION	59
15.3	CONTROLLER AND NETWORK CABLE CONNECTION.....	59
16	FAULT FINDING	60

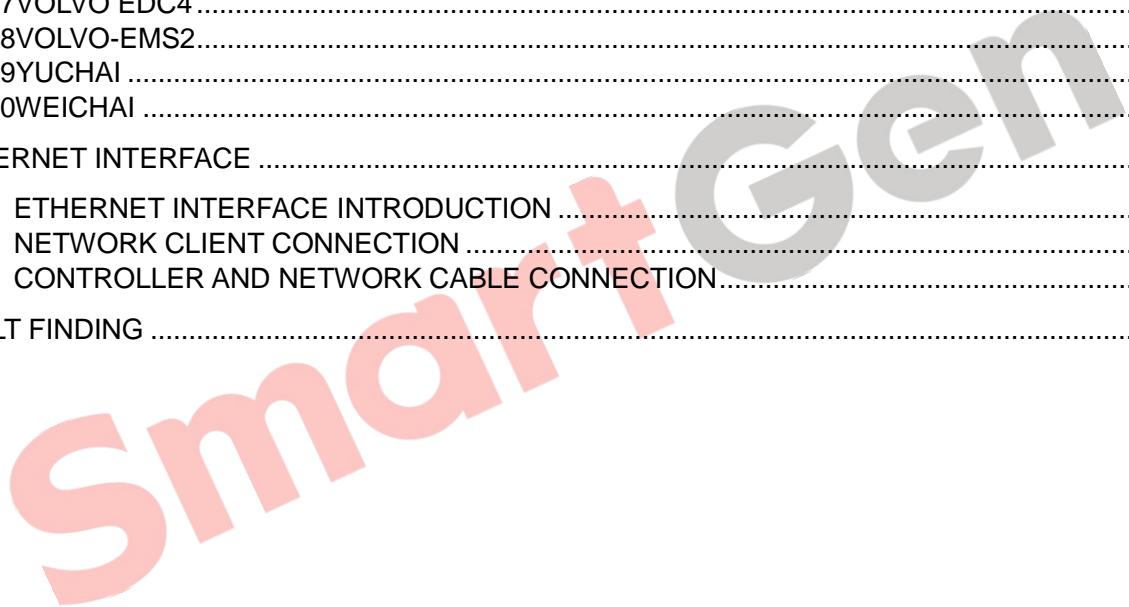

1 OVERVIEW

HGM8110DC genset controller is especially designed for single unit system in DC and AC applications, which can adapt extremely high/low temperature environment (-40~+70)°C. The controllers can operate reliability in extreme temperature conditions with the help of VFD display and the components that resist extreme temperature. Controller has strong ability of anti-electromagnetic interference, can be used under complex electromagnetic interference environment. It is easy to maintain and upgrade due to the plug-in terminal. Enable selecting different languages including Chinese, English and other languages.

HGM8110DC genset controller integrates digitization, intelligentization and network technology which is used for genset automation and monitor control system of single unit to achieve automatic start/stop, DC and AC data measurement, alarm protection and “three remote” functions(remote control, remote measuring and remote communication).

HGM8110DC genset controller adopts 32-bit micro-processor technology with precision parameters measuring, fixed value adjustment, time setting and set value adjusting and etc. Majority parameters can be configured from front panel, and all parameters can be configured by PC via RS485 interface or ETHERNET to adjust and monitor. It can be widely used in all types of automatic genset control system with compact structure, advanced circuits, simple connections and high reliability.

SmartGen

2 MOUDLES COMPARISON

HGM8100N series controller include HGM8110V, HGM8120V, HGM8110CAN, HGM8120CAN.

HGM8110N been collectively named of HGM8110V and HGM8110CAN.

HGM8120N been collectively named of HGM8120V and HGM8120CAN.

HGM8110DC is the optimize version for HGM8110CAN.

HGM8110DC and **HGM8100N** modules comparison is as below,

Table 3 - Moudles Comparison

Modules	HGM8110DC	HGM8110V	HGM8120V	HGM8110CAN	HGM8120CAN
Display	VFD				
DC Monitoring	•				
Mains Monitoring			•		•
Input Number	8	8	8	8	8
Output Number	8	8	8	8	8
Sensor Number	5	5	5	5	5
Earth Current	•	•	•	•	•
Schedule Function	•	•	•	•	•
RS485	•	•	•	•	•
ETHERNET	•			•	•
GSM		•	•	•	•
RS232	•				
J1939	•			•	•
USB	•	•	•	•	•
Real-time Clock	•	•	•	•	•
Event Log	•	•	•	•	•
Expand Input/Output	•			•	•

▲NOTE:

- 1) **Two fixed output ports: start output and fuel output.**
- 2) **Analog quantity sensor consists of three fixed sensors (temperature sensor, pressure sensor and fuel level sensor) and two flexible sensors.**

3 PERFORMANCE AND CHARACTERISTICS

HGM8110DC: It is DC genset controller and used for single automation systems. Control genset start/stop through remote signals control; Compared with **HGM8110CAN**, **HGM8110DC** added generator DC electric quantity monitoring and alarming functions, which is especially suit for single unit automatic system composed by 1-way DC and 1-way AC circuits.

Main characteristics are as below,

- With ARM-based 32-bit SCM, highly integrated hardware, new reliability level;
- Vacuum fluorescent display (VFD), selectable Chinese/English interface which can be chosen at the site, making commissioning convenience for factory personnel;
- LCD adopts hard screen acrylic material with good wear-resisting and scratch-resisting;
- Silicone panel and pushbuttons can be used in extreme temperature environment;
- RS485 and RS232 communication interfaces enable “Three remote functions” (remote control, remote measuring and remote communication) according to MODBUS protocol;
- Ethernet monitoring can be realized via ETHERNET communication interface (need controller with Ethernet interface);
- Equipped with CANBUS port and can communicate with J1939 genset. Not only can monitor frequently-used data (such as water temperature, oil pressure, speed, fuel consumption and so on) of ECU machine, but also control starting up, shutdown , raising speed and speed droop via CANBUS port (need controller with CANBUS interface);
- Suitable for 3-phase 4-wire, 3-phase 3-wire, single phase 2-wire, and 2-phase 3-wire systems with voltage 120/240V and system with frequency 50/60Hz and 400Hz;
- Collects and shows AC 3-phase voltage, current, power parameters:
- Collects and shows DC 3-phase voltage, current, power parameters:

AC

Line voltage (Uab, Ubc, and Uca)
 Phase voltage (Ua, Ub, and Uc)
 Phase sequence
 Frequency Hz

DC

voltage U
 Current I

Load

Current	Ia, Ib, Ic	A (unit)
Each phase and total active power	P	kW (unit)
Each phase and total reactive power	Q	Kvar (unit)
Each phase and total apparent power	S	kVA (unit)
Each phase and average power factor	λ	1 (unit)
Accumulate total generator power	W	kWh, kvarh, kVAh (unit)
Earth current	I	A (unit)

- For AC, controller has over and under voltage, over and under frequency, over current, over power, reverse power, loss of phase and phase rotation detection functions; for DC, controller has over and under voltage, over current, and over power detection functions;
- 3 fixed analog sensors (temperature, oil pressure and fuel level).
- 2 configurable sensors can be set as sensor of temperature, oil pressure or fuel level; resistor/voltage/current type sensors are supported;
- Precision measure and display parameters about Engine.

Temp. (WT)	°C/°F can be selected
Oil pressure (OP)	kPa/psi/bar can be selected

Fuel level (FL) %(unit)
Speed (SPD) r/min (unit)
Voltage of Battery (VB) V (unit)
Voltage of Charger (VD) V (unit)

Hour count (HC) can accumulate to max. 65535 hours.

Start times can accumulate to max. 65535 times.

- Protection: automatic start/stop of the diesel gen-set, ATS(Auto Transfer Switch) control with perfect fault indication and protection function.
- All output ports are relay-out;
- Parameter setting: parameters can be modified and stored in internal FLASH memory and cannot be lost even in case of power outage; most of them can be adjusted using front panel of the controller and all of them can be modified using PC via USB, RS485, RS232 or ETHERNET ports.
- More kinds of curves of temperature, oil pressure, and fuel level can be used directly and users can define the sensor curves by themselves.
- Multiple crank disconnect conditions (speed sensor, oil pressure, generator frequency) are optional.
- Widely power supply range DC(8~35)V, suitable to different starting battery voltage environment;
- Event log, real-time clock, scheduled start & stop generator (can be set as start genset once a day/week/month whether with load or not).
- PLC (Programmable Logic Controller) function. Users can use graphical programming to achieve specific functions.
- Can be used as an indicating instrument (indicate and alarm are enable only, relay is inhibited).
- With maintenance function. Actions (warning, shutdown or trip and stop) can be set when maintenance time out.
- All parameters used digital adjustment, instead of conventional analog modulation with normal potentiometer, more reliability and stability;
- Waterproof security level IP65 due to rubber seal installed between the controller enclosure and panel fascia;
- Metal fixing clips enable perfect in high temperature environment;
- Modular design, pluggable connection terminals and embedded installation way; compact structure with easy mounting.
- With accumulative running A, B and accumulative power A, B function, users can eliminate log event and re-accumulating, thus provide convenient for users statistic.

4 SPECIFICATION OPERATION

Table 4 - Technical Parameters

Items	Contents
Operating Voltage	DC8.0V to DC35.0V, Continuous Power Supply.
Power Consumption	<4W (standby \leq 2W)
Alternator Input Range 3Phase 4Wire 3Phase 3Wire Single Phase 2Wire 2Phase 3Wire	AC15V-AC 360V (ph-N) AC30V - AC620V (ph-ph) AC15V - AC360V (ph-N) AC15V - AC360V (ph-N)
DC Generator Voltage Input	DC 0V - 10V
Alternator Frequency	50 /60Hz, 400Hz
Speed sensor voltage	1.0V to 24.0V (RMS)
Speed sensor Frequency	10,000 Hz (max.)
Start Relay Output	16 A DC28V at supply output
Fuel Relay Output	16 A DC28V at supply output
Programmable Relay Output (1)	7 A DC28V at supply output
Programmable Relay Output (2)	7 A DC28V at supply output
Programmable Relay Output (3)	7A DC28V at supply output
Programmable Relay Output (4)	7A AC250V voltage free output
Programmable Relay Output (5)	8 A AC250V voltage free output
Programmable Relay Output (6)	8 A AC250V voltage free output
Case Dimension	242mm x186mm x53mm
Panel Cutout	214mm x160mm
CT Secondary Current	5A rated
Working Conditions	Temperature: (-40~+70)°C; Relative Humidity: (20~93)%RH
Storage Condition	Temperature: (-40~+70)°C
Protection Level	IP65: when rubber seal installed between the controller enclosure and panel fascia.
Insulating Intensity	Apply AC2.2kV between high volt terminal and low volt terminal; The leakage current is not more than 3mA within 1min.
Net Weight	0.85kg

5 OPERATION

5.1 INDICATORS

Table 5 - Alarm Indicators

Alarm Type	Alarm Indicator
No Alarm	Indicator off
Warning	Slow flashing(1time/s)
Trip Alarm	Slow flashing(1time/s)
Shutdown Alarm	Fast flashing(5 times/s)
Trip and Stop Alarm	Fast flashing(5 times/s)









 **NOTE: Partial indicators description,**







Status indicator: illuminated from crank disconnect to ETS while off during other periods.



Gens normal Indicator: It is light on when generator is normal; flashing when generator state is abnormal; off when there is no generator power.

5.2 KEY FUNCTION

Table 6 - Key Function Descriptions

Icon	Key	Description
	Stop	Stop running generator in Auto/Manual mode; Reset alarms in stop mode; Lamp test (press at least 3 seconds); During stopping process, press this button again to stop generator immediately.
	Start	Start genset in Manual mode.
	Manual Mode	Press this key and controller enters in Manual mode.
	Auto Mode	Press this key and controller enters in Auto mode.
	Mute/Reset Alarm	Alarming sound off; If there is trip alarm, pressing the button at least 3 seconds can reset this alarm.
	Close	Can close breaker in manual mode
	Open	Can open breaker in manual mode
	Set	Enter setting interface

Icon	Key	Description
	Up/Increase	1) Screen scroll; 2) Up cursor and increase value in setting menu.
	Down/Decrease	1) Screen scroll; 2) Down cursor and decrease value in setting menu.
	Left	1. Screen scroll; 2. Left move cursor in setting menu.
	Right	1. Screen scroll; 2. Right move cursor in setting menu.
	Confirm	In settings menu confirms the set value.
	Exit	1. Returns to the previous screen; 2. In settings menu returns to the upper level menu.

NOTE: In manual mode, pressing  and  simultaneously will force generator to crank. Successful start will not be judged according to crank disconnect conditions, operator will have to crank the starter motor manually; when operator decides that the engine has fired, he/she should release the button and start output will be deactivated, safety on delay will start.

WARNING: Default password is "00318", user can change it in case of others change the advanced parameters setting. Please clearly remember the password after changing.

If you forget it, please contact SmartGen services and send PD information in the controller page of "ABOUT" to us.

5.3 LCD DISPLAY

5.3.1. MAIN DISPLAY

Main screen show pages; use   to scroll the pages and   to scroll the screen.

★**Main Screen**, including as below,

Partial status display;

AC Gen: voltage, frequency,

AC Load: current, active power, reactive power, power factor;

DC Gen: voltage, current, power, total energy;

Engine: speed, temperature, oil pressure

NOTE: it will circulatory scroll pages if no action after enter the main display.

★**Status**, including as below,

Status of genset, and ATS

★**Engine**, including as below,

Speed, temperature of engine, engine oil pressure, fuel level, Configure Sensor 1, Configure Sensor 2, battery voltage, charger voltage, accumulated run time, accumulated start times, user A and user B accumulated start times.

NOTE: If connected with J1939 engine via CANBUS port, this page also includes: coolant pressure, coolant level, fuel temperature, fuel pressure, inlet temperature, exhaust temperature, turbo pressure, fuel

consumption, total fuel consumption and so on. (Different engine with different parameters)

★**AC Gen**, including as below,

Phase voltage, Line voltage, frequency, phase sequence.

★**AC Load**, including as below

Current of each phase, each phase and total active power (positive and negative), each phase and total reactive power (positive and negative), each phase and total apparent power, each phase and average power factor (positive and negative), accumulated energy earth current and user A and user B accumulated energy.

▲**NOTE:** Power factor shows as following,

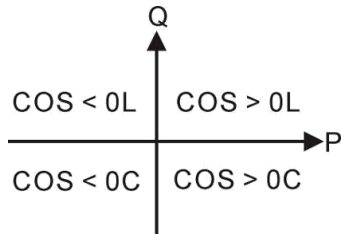

Remark:

P stands for active power

Q stands for inactive power

Table 7 Power Factor Descriptions

Power factor	Conditions	Active power	Inactive power	Remark
COS>0L	P>0,Q>0	Input	Input	Load is inductive resistance.
COS>0C	P>0,Q<0	Input	Output	Load is capacitance resistance.
COS<0L	P<0,Q>0	Output	Input	Load equal to one under excitation generator
COS<0C	P<0,Q<0	Output	Output	Load equal to one over excitation generator.

Remark:

1. Input active power, generator or mains supply electricity to load.
2. Output active power, load supply electricity to generator or mains.
3. Input reactive power, generator or mains send reactive power to load.
4. Output reactive power, load send reactive power to generator or mains.

★**DC GEN**, including as below,

Voltage, current, power and accumulated energy

★**Alarm:**

Display all alarm information, including warning, alarm shutdown, trip shutdown and trip.

▲**NOTE:** For ECU warning and shutdown alarms, if the detailed alarm information is displayed, check engine according to it, otherwise, please check the manual of generator according to SPN alarm code.

★**Event log**

Records all start/stop events (shutdown alarm, trip and stop alarm, manual /auto start or stop) and the real time when alarm occurs.

★**Others**, including,

Time and Date, count down time for maintenance, input/output ports status, NET status etc.

★**About**, including,

Issue time of software and hardware version and PD number of controller

5.3.2. PARARMETERS SETTING MANUAL

Press and hold  for more than 3 seconds to enter user menu;

Parameter: After entering the correct password (factory default password is 00318) you can enter parameter settings screen.

Language: Selectable Chinese, English and others (default: Espanol)

Commissioning: On load, off load and custom commissioning are optional. Custom commissioning can configure on load or not during commissioning, when to commissioning and select the mode after commissioning (manual mode, auto mode and stop mode).

Clear users' accumulation: Can clear total run time A and B, total electric energy A and B.

5.3.3. PARAMETER SETTINGS

- DC generator settings
- Timers settings
- Engine settings
- AC Generator settings
- AC Load settings
- Breaker settings
- Temperature sensor settings
- Oil pressure sensor settings
- Level sensor settings
- Flexible sensor 1 settings
- Flexible sensor 2 settings
- Digital inputs settings
- Relay Outputs settings
- Module settings
- Scheduling and maintenance settings
- Expansion module settings

 **NOTE:** Pressing  can exit setting directly during setting.

5.4 AUTO START/STOP OPERATION

Press , its indicator lights, and controller enters **Auto** mode.

Starting Sequence,





- 1) **HGM8110DC:** Generator enters into “Start Delay” as soon as “Remote Start on Load” is active.
- 2) Start delay timer is shown on LCD.
- 3) When start delay is over, preheat relay outputs (if this be configured), “Preheat Start Delay XX s” is shown on LCD.
- 4) When preheat delay is over, fuel relay outputs 1s and then start relay output; if engine crank fails during “Cranking Time”, the fuel relay and start relay deactivated and enter into “Crank Rest Time” to wait for next crank.
- 5) If engine crank fails within setting times, the controller sends “Fail to Start” signals and “Fail to Start” message appears on LCD alarm page.
- 6) In case of successful crank attempt, “Safety on Timer” starts. During this period, low oil pressure, high water temperature, under speed, charge failure alarms are disabled. As soon as this delay is over, “Start Idle Delay” is initiated (if configured).
- 7) During “Start Idle Delay”, under speed, under frequency, under voltage alarms are inhibited. When this delay is over, “Warming Up Delay” starts (if configured).
- 8) When “Warming Up Delay” is over, if generator state is normal, its indicator will be illuminated. If voltage and frequency has reached on-load requirements, the closing relay will be energized, generator will accept load, generator power indicator will turn on, and generator will enter Normal Running state; if voltage and frequency are abnormal, the controller will initiate alarm (alarm type will be displayed on LCD alarm page).

▲NOTE: In case of “Remote Start (off Load)”, the procedure is the same, except for step NO. 8: the closing relay will NOT be energized, generator will NOT accept load.

Stopping Sequence:

- 1) HGM8110DC, generator enters into “stop delay” as soon as “Remote Start” is inactive.
- 2) When stop delay is over, close generator relay is un-energized; generator enters into “Cooling Time”. Generator indicator extinguish while mains indicator lights.
- 3) Idle relay is energized as soon as entering “Stop Idle Delay”.
- 4) If enter “ETS hold delay”, ETS relay is energized. Fuel relay is deactivated and decides whether generator is stopped or not automatically.
- 5) Then enter gen-set “Fail to stop time”, auto decides whether generator is stopped or not automatically.
- 6) Enter “After Stop Time” (if configured) as soon as generator stops. Otherwise, controller will send “Fail to Stop” alarm. (If gen-set stopped successfully after warning of “Failed to Stop”, it will enter “After Stop Time” and remove alarm)
- 7) Enter “Generator at Rest” as soon as “After Stop Time” is over.

5.5 MANUAL START/STOP OPERATION

- 1) **MANUAL START:** Press , controller enters into manual mode and its indicator lights. Press  to start generator, can automatically detect crank disconnected, and generator accelerates to high-speed running automatically. With high temperature, low oil pressure, over speed and abnormal voltage during generator running, controller can protect genset to stop quickly. Press  and  to open or close the switch. (Please refer to No.3~8 of Auto start operation for detail procedures, which the difference is only in the way of switch open and close).
- 2) **MANUAL STOP:** Press  can stop the running generators. (Please refer to No.2~7 of Auto stop operation for detail procedures).

▲Note: In “manual mode”, the procedures of ATS please refer to ATS procedure of generator in this manual.

SmartGen

5.6 GENSET CONTROLLER SWITCH CONTROL PROCEDURES

5.6.1. HGM8110DC SWITCH CONTROL PROCEDURES

5.6.1.1 MANUAL TRANSFER PROCEDURES

When controller is in manual mode, manual control will be executive.

Users can control switch on or off by pressing key.

Press generator switch on key , generator will output load signals. Press generator switch off

key , generator will output unload signals.

5.6.1.2 AUTO CONTROL PROCEDURES

When controller is in auto mode, switch control procedures will start auto transfer.

1) If input port is configured as “Close Mains Auxiliary”

A. If “Open breaker detect” is “SELECT Enable”

Generator load is transferred into generator un-load, after the delay of switch off, detecting transfer failure while switch off output. When detecting time out, if switch off failed, it will wait for switch off. Otherwise, switch off is completed.

Generator unload is transferred into generator load, after the delay of switch on, detecting transfer failure while switch on outputting. When detecting time out, if switch on failed, it will wait for switch on. Otherwise, switch on is completed.

If transfer failed and warning “SELECT Enable”, there is alarming signals whatever switch on or off failure.

B. If “Open breaker detect” is “SELECT Disable”

Generator load is transferred into generator unload, after the delay of switch off, switch off is completed.

Generator unload is transferred into generator load, after the delay of switch on, detecting transfer failure while switch on outputting. When detecting time out, if switch on failed, to wait for switch on. Otherwise, switch on is completed.

If transfer failure warning is “SELECT Enable”, there is warning signal that “switch on fail”.

2) If input port is not configured as Close Mains Auxiliary

Generator un-load is transferred into generator load, close generator output.

Generator load is transferred into generator un-load, open generator output.

NOTE:

- 1) When using ATS of no interposition, switch off detecting should “SELECT Disable”;
- 2) When using ATS of having interposition, switch off “SELECT Disable” or “SELECT Enable” both are OK. If choose “SELECT Enable”, switch off output should be configured;
- 3) When using AC contactor, switch off “SELECT Enable” is recommended.

6 PROTECTION

6.1 WARNINGS

When controllers detects the warning signals, alarm only and not stop the genset.

Table 8 - Warning Alarms

No.	Type	Description
1	Over Speed	When controller detects the speed is higher than the set value, it will send warn signals.
2	Under Speed	When controller detects the speed is lower than the set value, it will send warn signals.
3	Loss of Speed Signal	When controller detects the speed is 0 and the action select "Warn", it will send warn signals.
4	AC Over Frequency	When controller detects the frequency of AC genset is higher than the set value, it will send warn signals.
5	AC Under Frequency	When controller detects the frequency of AC genset is lower than the set value, it will send warn signals.
6	AC Over Voltage	When controller detects the voltage of AC genset is higher than the set value, it will send warn signals.
7	AC Under Voltage	When controller detects the voltage of AC genset is lower than the set value, it will send warn signals.
8	AC Over Current	When controller detects the current of AC genset is higher than the set value and the action select "Warn", it will send warn signals.
9	Fail to Stop	When generator not stops after the "stop delay" is over, it will send warn signals.
10	Charge Alt Fail	When controller detects the charger voltage is lower than the set value, it will send warn signals.
11	Battery High Voltage	When controller detects the battery voltage is higher than the set value, it will send warn signals.
12	Battery Low Voltage	When controller detects the battery voltage is lower than the set value, it will send warn signals.
13	Maintenance Due	When count down time is 0 and the action select "Warn", it will send warn signals.
14	AC Reverse Power	When controller detects the reverse power value (power is negative) is higher than the set value and the action select "Warn", it will send warn signals.
15	AC Over Power	When controller detects the reverse power value (power is positive) is higher than the set value and the action select "Warn", it will send warn signals.
16	ECU Warn	When controller gets the alarm signals from engine via J1939, it will send warn signals.



No.	Type	Description
17	AC Loss of Phase	When controller detects the AC generator loss phase, it will send warn signals.
18	AC Phase Sequence Wrong	When controller detects the AC generator phase rotation, it will send warn signals.
19	Switch Fail	When controller detects the switch on and off fail, and the action select enable, it will send warn signals.
20	DC Over Voltage	When controller detects the voltage of DC genset is higher than the set value, it will send warn signals.
21	DC Under Voltage	When controller detects the voltage of DC genset is lower than the set value, it will send warn signals.
22	DC Over Current	When controller detects the current of DC genset is higher than the set value and the action select "Warn", it will send warn signals.
23	DC Over Power	When controller detects the reverse power value (power is positive) is higher than the set value and the action select "Warn", it will send warn signals.
24	Temp. Sensor Open	When controller detects the sensor is open circuit, and the action select "warn", it will send warn signals.
25	High Temp. Warn	When controller detects the temperature is higher than the set value, it will send warn signals.
26	Low Temp. Warn	When controller detects the temperature is lower than the set value, it will send warn signals.
27	Pressure Sensor Open	When controller detects the sensor is open circuit, and the action select "warn", it will send warn signals.
28	Low OP Warn	When controller detects the oil pressure is lower than the set value, it will send warn signals.
29	Level Sensor Open	When controller detects the sensor is open circuit, and the action select "warn", it will send warn signals.
30	Low Level Warn	When controller detects the oil lever is lower than the set value, it will send warn signals.
31	Flexible Sensor 1 Open	When controller detects the sensor is open circuit, and the action select "warn", it will send warn signals.
32	Flexible Sensor 1 High	When controller detects the sensor value is higher than the max. set value, it will send warn signals.
33	Flexible Sensor 1 Low	When controller detects the sensor value is lower than the min. set value, it will send warn signals.
34	Flexible Sensor 2 Open	When controller detects the sensor is open circuit, and the action select "warn", it will send warn signals.
35	Flexible Sensor 2 High	When controller detects the sensor value is higher than the max. set



No.	Type	Description
		value, it will send warn signals.
36	Flexible Sensor 2 Low	When controller detects the sensor value is lower than the min. set value, it will send warn signals.
37	Digital Input Warn	When digit input port is set as warning and active, controller sends corresponding warning signals.
38	Earth Fault	When controller detects earth current is greater than value of setting, and the action "Warn" alarm is set, it will send a warning alarm signals.

6.2 SHUTDOWN ALARM

When controller detects shutdown alarm, it will send signals to stop the generator.

Table 9 - Shutdown Alarms

No.	Type	Description
1	Emergency Stop	When controller detects emergency stop signals, it will send stop signals.
2	Over Speed	When controller detects the speed value is higher than the set value, it will send stop signals.
3	Under Speed	When controller detects the speed value is lower than the set value, it will send stop signals.
4	Loss of Speed Signal	When controller detects speed value equals to 0, and the action select "Shutdown", it will send stop signals
5	AC Over Frequency	When controller detects the frequency value of AC genset is higher than the set value, it will send stop signals.
6	AC Under Frequency	When controller detects the frequency value of AC genset is lower than the set value, it will send stop signals.
7	AC Over Voltage	When controller detects the voltage value of AC genset is higher than the set value, it will send stop signals.
8	AC Under Voltage	When controller detects the voltage value of AC genset is lower than the set value, it will send stop signals.
9	Fail to Start	If genset start failure within setting of start times, controller will send stop signals.
10	AC Over Current	When controller detects the current value of AC genset is higher than the set value, it will send stop signals.
11	Maintenance Due	When count down time is 0 and the action select "Shutdown", it will send stop signals.
12	ECU Shutdown	When controller receives engine shutdown signals via J1939, controller send stop signals.
13	ECU Com Fail Shutdown	After engine start, controller dos not receive data signals, via J1939, controller send stop signals.



No.	Type	Description
14	AC Reverse Power Shutdown	When controller detects reverse power value of AC genset (power is negative) is higher than the set value, and the reverse power action select "shutdown", it will send stop signals.
15	AC Over Power Shutdown	When controller detects reverse power value of AC genset (power is positive) is higher than the set value, and the reverse power action select "shutdown", it will send stop signals.
16	DC Over Voltage	When controller detects the voltage value of DC genset is higher than the set value, it will send stop signals.
17	DC Under Voltage	When controller detects the voltage value of DC genset is lower than the set value, it will send stop signals.
18	DC Over Current	When controller detects the current value of DC genset is higher than the set value, it will send stop signals.
19	DC Over Power Shutdown	When controller detects reverse power value of DC genset (power is positive) is higher than the set value, and the reverse power action select "shutdown", it will send stop signals.
20	Temp. Sensor Open	When controller detects sensor is open circuit, and the action select "shutdown", it will send stop signals.
21	High Temp. Shutdown	When controller detects temperature is higher than the set value, it will send stop signals.
22	Pressure Sensor Open	When controller detects sensor is open circuit, and the action select "shutdown", it will send stop signals.
23	Low Oil Pressure	When controller detects oil pressure is lower than the set value, it will send stop signals.
24	Level Sensor Open	When controller detects sensor is open circuit, and the action select "shutdown", it will send stop signals.
25	Flexible Sensor 1 Open	When controller detects sensor is open circuit, and the action select "shutdown", it will send stop signals.
26	Flexible Sensor 1 High	When controller detects the sensor value is higher than the max. set value, it will send stop signals.
27	Flexible Sensor 1 Low	When controller detects the sensor value is lower than the min. set value, it will send stop signals.
28	Flexible Sensor 2 Open	When controller detects sensor is open circuit, and the action select "shutdown", it will send stop signals.
29	Flexible Sensor 2 High	When controller detects the sensor value is higher than the max. set value, it will send stop signals.
30	Flexible Sensor 2 Low	When controller detects the sensor value is lower than the min. set value, it will send stop signals.
31	Digital Input Port	When digital input port is set as shutdown, and the action is active,

No.	Type	Description
	Shutdown	it will send stop signals.
32	Earth Fault	When controller detects the earth current of genset exceeds preset earth fault threshold and the earth fault action select "shutdown" it will send stop signals.

6.3 TRIP AND STOP ALARM

When controller detects trip and stop alarm signals, it will shutdown generator quickly and stop after high speed cooling.

Table 10 - Trip and Stop Alarms

No.	Type	Description
1	AC Over Current	When controller detects the current value of AC genset is higher than the set value, and the action select "trip and stop", it will send trip and stop signals.
2	Maintenance Due	When count down time is 0 and the action select "trip and stop", it will send a trip and stop signals.
3	AC Reverse Power	When controller detects reverse power value of AC genset (power is negative) is higher than the set value, and the action select "trip and stop", it will send a trip and stop signals.
4	AC Over Power	When controller detects the over power value of AC genset (power is positive) is higher than the set value, and the action select "trip and stop", it will send a trip and stop signals.
5	DC Over Current	When controller detects the current value of DC genset is higher than the set value, and the action select "trip and stop", it will send trip and stop signals.
6	DC Over Power	When controller detects the over power value of AC genset (power is positive) is higher than the set value, and the action select "trip and stop", it will send a trip and stop signals.
7	Digital Input Ports	When digital input port is set as "trip and stop", and the action is active, it will send a trip and stop signals.
8	Earth Fault	When controller detects the earth current of genset exceeds preset earth fault threshold and the earth fault action select "trip and stop" it will send trip and stop signals.

6.4 TRIP ALARM

When controller detects trip alarm, it will break close generator signals quickly, but genset not stop.

Table 11 - Trip Alarms

No.	Type	Description
1	AC Over Current	When controller detects the current value of AC genset is higher than the set value, and the action select "trip", it will send trip signals.
2	AC Reverse Power	When controller detects reverse power value (power is negative) is higher than the set value, and the action select "trip", it will send a trip signals.
3	AC Over Power	When controller detects the over power value of AC genset (power is positive) is higher than the set value, and the action select "trip", it will send a trip signals.
4	DC Over Current	When controller detects the current value of DC genset is higher than the set value, and the action select "trip", it will send trip signals.
5	DC Over Power	When controller detects the over power value of DC genset (power is positive) is higher than the set value, and the action select "trip", it will send a trip signals.
4	Digital Input Ports	When digital input port is set as "trip", and the action is active, it will send a trip signals.
5	Earth Fault	When controller detects the earth current of genset exceeds preset earth fault threshold and the earth fault action select "trip" it will send a trip signals.

7 WIRINGS CONNECTION

HGM8110DC series controller's back as following:

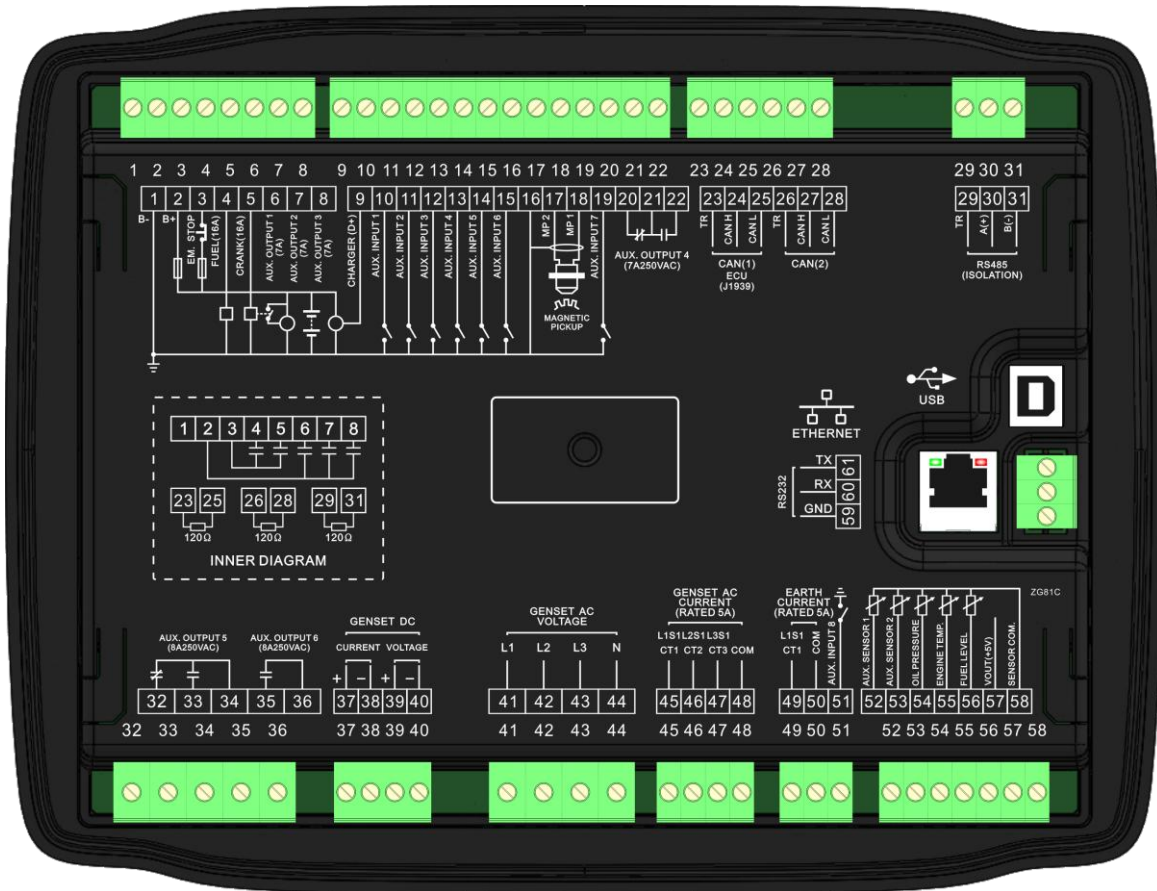

Fig.1 - HGM8110DC Back Panel

Table 12 - Terminal Wiring Connection

No.	Function	Cable Size	Remarks	
1	B-	2.5mm ²	Connected with negative of starter battery	
2	B+	2.5mm ²	Connected with positive of starter battery. If wire length is over 30m, better to double wires in parallel. Max. 20A fuse is recommended.	
3	Emergency stop	2.5mm ²	Connected with B+ via emergency stop button	
4	Fuel relay output	1.5mm ²	B+ is supplied by No.3 terminal, rated 16A	
5	Start relay output	1.5mm ²	B+ is supplied by No.3 terminal, rated 16A	Connected to starter coil
6	Aux. Output 1	1.5mm ²	B+ is supplied by No.2 terminal, rated 7A	Details see Table 14
7	Aux. Output 2	1.5mm ²	B+ is supplied by No.2 terminal, rated 7A	
8	Aux. Output 3	1.5mm ²	B+ is supplied by No.2 terminal, rated 7A	



No.	Function	Cable Size	Remarks
9	Charger(D+)	1.0mm ²	Connected with charger starter's D+ (WL) terminals. Being hang up If there is no this terminal.
10	Aux. Input 1	1.0mm ²	Ground connected is active (B-)
11	Aux. Input 2	1.0mm ²	Ground connected is active (B-)
12	Aux. Input 3	1.0mm ²	Ground connected is active (B-)
13	Aux. Input 4	1.0mm ²	Ground connected is active (B-)
14	Aux. Input 5	1.0mm ²	Ground connected is active (B-)
15	Aux. Input 6	1.0mm ²	Ground connected is active (B-)
16	Magnetic Pickup	0.5mm ²	Connected with Speed sensor, shielding line is recommended. (B-) has already connected with speed sensor 2
17	MP 2		
18	MP 1		
19	Aux. Input 7	1.0mm ²	Ground connected is active (B-)
20	Aux. Output 4	1.5mm ²	Normally close output, rated 7A
21			Public points of relay
22			Normally open output, rated 7A
23	ECU CAN	/	Impedance-120Ω shielding wire is recommended, its single-end earthed.
24	ECU CAN H	0.5mm ²	
25	ECU CAN L	0.5mm ²	
26	CAN2 Common port	/	Impedance-120Ω shielding wire is recommended, its single-end earthed.
27	CAN2 H	0.5mm ²	
28	CAN2 L	0.5mm ²	
29	RS485 Common port	/	Impedance-120Ω shielding wire is recommended, its single-end earthed.
30	RS485A(+)	0.5mm ²	
31	RS485B(-)	0.5mm ²	
32	Aux. Output 5	2.5mm ²	Normally close output, rated 8A
33		2.5mm ²	Normally open output, rated 8A
34		2.5mm ²	Relay common port
35	Aux. Output 6	2.5mm ²	Normally open output, rated 8A
36		2.5mm ²	Relay common port
37	DC Current +	1.0mm ²	External connected to DC positive of current transformer
38	DC Current -	1.0mm ²	External connected to DC negative of current transformer
39	DC Voltage +	1.0mm ²	External connected to DC positive of current transformer
40	DC Voltage -	1.0mm ²	External connected to DC negative of current transformer



No.	Function	Cable Size	Remarks	
41	AC Gen A-Phase Volt Input	1.0mm ²	Connected to A-phase of AC gen-set (2A fuse is recommended)	
42	AC Gen B-Phase Volt Input	1.0mm ²	Connected to B-phase of AC gen-set (2A fuse is recommended)	
43	AC Gen C-Phase Volt Input	1.0mm ²	Connected to C-phase of AC gen-set (2A fuse is recommended)	
44	AC Gen N-Line Volt Input	1.0mm ²	Connected to N-line of AC gen-set	
45	AC CT A-Phase Input	1.5mm ²	External connected to secondary coil of current transformer(rated 5A)	
46	AC CT B-Phase Input	1.5mm ²	External connected to secondary coil of current transformer(rated 5A)	
47	AC CT C-Phase Input	1.5mm ²	External connected to secondary coil of current transformer(rated 5A)	
48	AC CT COM	1.5mm ²	See following installation instruction	
49	Earth Current	1.5mm ²	External connected to secondary coil of current transformer(rated 5A)	
50		1.5mm ²		
51	Aux. Input 8	1.0mm ²	Ground connected is active (B-)	Details see Table 15
52	Aux. sensor 1	1.0mm ²	Connected to temperature, oil pressure or fuel level sensors	Details see Table 16
53	Aux. sensor 2	1.0mm ²		
54	Oil pressure sensor	1.0mm ²		
55	Temperature sensor	1.0mm ²		
56	Fuel level sensor	1.0mm ²		
57	VOUT(+5V)	1.0mm ²	+5V output, using to supply power for voltage type sensor.	
58	Sensor COM	/	Sensor common port, controller internal has been connected to negative of battery.	
59	RS232 COM	0.5mm ²	RS232 port	
60	RS232 RX	0.5mm ²		
61	RS232 TX	0.5mm ²		

NOTE: USB ports in controller rear panel are programmable parameter ports, user can directly configure controller via PC.

NOTE: Ethernet ports in controller rear panel are website port, user can directly configure and monitor controller via PC.

8 SCOPES AND DEFINITIONS OF PROGRAMMABLE PARAMETERS

8.1 CONTENTS AND SCOPES OF PARAMETERS

Table 13 - Parameters Contents and Scopes

No.	Items	Parameters	Defaults	Description
DC Generator				
1	Work Mode	(0~2)	0	0: DC; 1: AC 2: DC+AC
2	Rated Voltage	(10~30000)V	500	Standard for checking DC generator over/under voltage.
3	Loading Voltage	(0-100)%	90	Setting value is DC generator rated voltage's percentage. The controller detects in the preparation of the load period, and does not enter the normal running period when the generator voltage is less than the load voltage.
4	PT Ratio	(10-30000)V/10V	1000	Ratio of the external connected DC voltage transformer.
5	Rated Current	(10-6000)A	300	Rated full load current of DC generator, which is used as the standard for load power.
6	CT Ratio	(10-6000)A/20mA	400	Ratio of the external connected DC current transformer.
7	Rated Power	(10-6000)kW	100	It is rated power for DC generator, which is used as the standard for load power.
8	Over Voltage Shutdown	(0-200)%	120	Setting value is DC generator rated voltage's percentage, delay value (default 1s) can be set.
9	Under Voltage Shutdown	(0-200)%	80	
10	Over Voltage Warn	(0-200)%	110	Setting value is DC generator rated voltage's percentage, return value (over voltage default is 105, under voltage default is 95) and delay value (default 5s) can be set.
11	Under Voltage Warn	(0-200)%	90	
12	Over Current	(0-200)%	110	Setting value is DC generator rated current's percentage, alarm action (default: warning) and delay value (default 5s) can be set.
13	Over Power	(0-200)%	110	Setting value is DC load rated power's percentage, alarm action (default: warning) and delay value (default 5s) can be set.
Timers				
1	Start Delay	(0~3600)s	1	Time from mains abnormal or remote start



No.	Items	Parameters	Defaults	Description
				signal is active to start genset.
2	Stop Delay	(0~3600)s	1	Time from mains normal or remote start signal is deactivated to genset stop.
3	Preheat Delay	(0~3600)s	0	Time of pre-powering heat plug before starter is powered up.
4	Cranking Time	(3~60)s	8	Time of starter power up
5	Crank Rest Time	(3~60)s	10	The waiting time before second power up when engine start fail.
6	Safety On Delay	(0~3600)s	10	Alarms for low oil pressure, high temperature, under speed, under frequency /voltage, charge fail are inactive.
7	Start Idle Time	(0~3600)s	0	Idle running time of genset when starting.
8	Warming Up Time	(0~3600)s	10	Warming time between genset switch on and normal running.
9	Cooling Time	(0~3600)s	10	Radiating time before genset stop, after it unloads.
10	Stop Idle Time	(0~3600)s	0	Idle running time when genset stop.
11	ETS Solenoid Hold	(0~3600)s	20	The time of powering up the electromagnet during stop procedure.
12	Wait Stop Delay	(0~3600)s	0	Time between ending of genset idle delay and stopped when "ETS time" is set as 0; Time between ending of ETS hold delay and stopped when "ETS Hold output time" is not 0.
13	After Stop Time	(0~3600)s	0	Time between genset stopped and standby
Engine				
1	Engine Type	(0~39)	0	Default: Conventional engine When connected to J1939 engine, choose the corresponding type.
2	Flywheel Teeth	(10~300)	118	Tooth number of the engine, for judging of crank disconnect conditions and inspecting of engine speed. See the installation instructions.
3	Rated Speed	(0~6000)r/min	1500	Offer standard to judge over/under/loading speed.
4	Speed On Load	(0~100)%	90	Setting value is percentage of rated speed. Controller detects when it is ready to load. It won't switch on when speed is under loading speed.
5	Loss of Speed Signal	(0~3600)s	5	Time from detecting speed is 0 to confirm the action.
6	Action	(0~1)	0	0: Warning; 1: Shutdown
7	Over Speed	(0~200)%	114	Setting value is percentage of rated speed



No.	Items	Parameters	Defaults	Description
	Shutdown			and delay value (over speed default: 2s; under speed default:3s) also can be set.
8	Under Speed Shutdown	(0~200)%	80	
9	Over Speed Warn	(0~200)%	110	Setting value is percentage of rated speed and delay value (default: 5s) and return value (default: over speed: 108; under speed: 90) also can be set.
10	Under Speed Warn	(0~200)%	86	
11	Battery Rated Voltage	(0~60.0)V	24.0	Standard for detecting over/under voltage of battery.
12	Battery Over Volt Warn	(0~200)%	120	Setting value is percentage of rated voltage of battery. Delay value (default: 60s) & return value (default: over voltage: 115; under voltage: 90) also can be set.
13	Battery Under Volt Warn	(0~200)%	85	
14	Charge Alt Failure	(0~60.0)V	8.0	In normal running, when charger D+(WL) voltage under this value, charge failure alarms.
15	Start Attempts	(1~10) times	3	Max. crank times of crank attempts. When reach this number, controller will send start failure signal.
16	Crank Disconnect	(0~6)	2	See Table 17 There are 3 conditions of disconnecting starter with engine. Each condition can be used alone and simultaneously to separating the start motor and genset as soon as possible.
17	Disconnect Generator Freq	(0~200)%	24	Setting value is percentage of gen rated frequency. When generator frequency higher than the set value, starter will be disconnected. See the installation instruction.
18	Disconnect Speed	(0~200)%	24	Setting value is percentage of gen rated speed. When generator's speed higher than the set value, starter will be disconnected. See the installation instruction.
19	Disconnect Oil Pressure	(0~1000)kPa	200	When generator oil pressure higher than the set value, starter will be disconnected. See the installation instruction.
AC Generator				
1	AC System	(0~3)	0	0: 3P4W; 1: 3P3W; 2: 2P3W; 3: 1P2W.
2	Poles	(2~64)	4	Numbers of generator pole, used for calculating starter rotate speed when



No.	Items	Parameters	Defaults	Description
				without speed sensor.
3	Rated Voltage	(30~30000)V	230	To offer standards for detecting of generator' over/under voltage and loading voltage. It is primary voltage when using voltage transformer.
4	Loading Voltage	(0~200)%	85	Setting value is AC generator rated voltage's percentage. The controller detects in the preparation of the load period, and does not enter the normal running period when the generator voltage is less than the load voltage.
5	Rated Frequency	(10.0~600.0) Hz	50.0	To offer standards for detecting of over/under/load frequency.
6	Loading Frequency	(0~200)%	85	Setting value is AC generator rated frequency's percentage. The controller detects in the preparation of the load period, and does not enter the normal running period when the generator voltage is less than the load voltage.
7	PT Fitted	(0~1)	0	0: Disable; 1: Enable
8	Over Volt. Shutdown	(0~200)%	120	Setting value is percentage of AC generator rated volt. Delay value (default: 3s) also can be set.
9	Under Volt. Shutdown	(0~200)%	80	
10	Over Freq. Shutdown	(0~200)%	114	Setting value is percentage of AC generator rated freq. Delay value (default: over frequency: 2s; under frequency: 3s) also can be set
11	Under Freq. Shutdown	(0~200)%	80	
12	Over Volt. Warn	(0~200)%	110	Setting value is percentage of generator rated volt. Delay value (default: 5s) and return value (default: over voltage: 108; under voltage: 86) also can be set.
13	Under Volt. Warn	(0~200)%	84	
14	Over Freq. Warn	(0~200)%	110	Setting value is percentage of generator rated freq. Delay value (default: 5s) and return value (default: over frequency: 108; under frequency: 86) also can be set.
15	Under Freq. Warn	(0~200)%	84	
16	Loss of Phase	(0~1)	1	0: Disable 1: Enable
17	Phase Sequence Wrong	(0~1)	1	
AC Load				
1	Current Transform	(5~6000)A/5A	500	The ratio of external CT
2	Rated Current	(5~6000)A	500	Generator's rated current, standard of load



No.	Items	Parameters	Defaults	Description
				current.
3	Rated Power	(0~6000)kW	276	Generator's rated power, standard of load power.
4	Over Current	(0~200)%	120	Setting value is percentage of AC generator rated full load current. Delay value also can be set as fixed time lag or inverse time lag.
5	Reverse Power	(0~1)	0	0: Disable 1: Enable
6	Action	(0-3)	0	0: Warning; 1: Shutdown; 3: Trip and Stop; 4: Trip
7	Over Power	(0~1)	0	0: Disable 1: Enable
8	Action	(0-3)	0	0: Warning; 1: Shutdown; 3: Trip and Stop; 4: Trip
Breaker				
1	Close Time	(0~20.0)s	5.0	Pulse width of generator switch on. When it is 0, means output constantly.
2	Open Time	(0~20.0)s	3.0	Pulse width of generator switch off.
3	Check Time	(0~20.0)s	5.0	Time of detecting switch auxiliary contacts after ATS breaker transferred.
4	Open Check	(0~1)	0	0: Disable 1: Enable
5	Check Fail Warn	(0~1)	1	0: Disable 1: Enable
Module				
1	Power on Mode	(0~2)	0	0: Stop mode 1: Manual mode 2: Auto mode
2	Module Address	(1~254)	1	Controller's address during remote sensing.
4	Language	(0~2)	0	0: Chinese 1: English 2: Other
5	Password	(0~65535)	00318	For entering advanced parameters setting.
6	Time and Date			Current time and date can be set by users.
7	IP Set	(0-1)	1	0: Disable 1: Enable All the settings about Ethernet (such as IP address and subnet mask) will active after the next time power on.
Scheduling And Maintenance Setting				
1	Scheduled Run	(0~1)	0	0: Disable; 1: Enable
2	Maintenance	(0~1)	0	0: Disable; 1: Enable
3	Scheduled Not Run	(0~1)	0	0: Disable; 1: Enable
Sensor				
Temperature Sensor				
1	Curve Type	(0~15)	9	SGD See Table 16.
2	Open Circuit Action	(0~2)	0	0: Warning; 1: Shutdown;



No.	Items	Parameters	Defaults	Description
				2: No action
3	High Shutdown	(0~300)°C	98	Shutdown when sensor temperature is higher than this value. Detecting only after safety delay is over. The delay value (default: 3s) also can be set.
4	High Warning	(0~300) °C	95	Warn when sensor temperature is higher than this value. Detecting only after safety delay is over. The delay value (default: 5s) and return value (default: 93) also can be set.
5	Low Warning	(0~1)	0	0: Disable; 1: Enable
6	Custom Curve			Users can configure it according to sensor's performance.
Oil Pressure Sensor				
1	Curve Type	(0~15)	9	SGD See Table 16.
2	Open Circuit Action	(0~2)	0	0: Warning 1: Shutdown 2: No action
3	Low Shutdown	(0~1000)kPa	103	Shutdown when oil pressure is lower than this value. Detecting only after safety delay is over. The delay value (default: 3s) also can be set.
4	Low Warning	(0~1000)kPa	124	Warn when oil pressure is lower than this value. Detecting only after safety delay is over. The delay value (default: 5s) and return value (default: 138) also can be set.
5	Custom Curve			Users can configure it according to sensor's performance.
Level Sensor				
1	Curve Type	(0~15)	5	SGH See Table 16
2	Open Circuit Action	(0~2)	0	0: Warning; 1: Shutdown; 2: No action
3	Low Warning	(0~300)%	10	Warn when level is lower than this value. It is detecting all the time. The delay value (default: 5s) and return value (default: 15) also can be set.
4	Custom Curve			Users can configure it according to sensor's performance.
Flexible Sensor 1				
1	Flexible Sensor 1 Setting	(0~1)	0	0: Disable 1: Enable; (can be set as temperature/pressure/ lever sensor).
Flexible Sensor 2				
1	Flexible Sensor 2 Setting	(0~1)	0	0: Disable; 1: Enable; (can be set as temperature/pressure/ lever sensor).
Digital Inputs				



No.	Items	Parameters	Defaults	Description
Digital Input Port 1				
1	Contents Setting	(0~55)	28	Remote start On Load. See Table 15
2	Active Type	(0~1)	0	0: Closed to Activate 1: Open to Activate
Digital Input Port 2				
1	Contents Setting	(0~55)	26	High Temperature Shutdown See Table 15
2	Active Type	(0~1)	0	0: Closed to Activate 1: Open to Activate
Digital Input Port 3				
1	Contents Setting	(0~55)	27	Low Oil Pressure Shutdown See Table 15
2	Active Type	(0~1)	0	0: Closed to Activate 1: Open to Activate
Digital Input Port 4				
1	Contents Setting	(0~55)	0	User Configured. See Table 15
2	Active Type	(0~1)	0	0: Closed to Activate 1: Open to Activate
3	Arming	(0~3)	2	0: From safety on 1: From Crank 2: Always 3: Never
4	Active Actions	(0~4)	0	0: Warning; 1: Shutdown; 2: Trip and stop 3: Trip 4: Indication
5	Active Delay	(0~20.0)s	2.0	Time from detecting active to confirm
6	Description			LCD display detailed contents when the input is active.
Digital Input Port 5				
1	Contents Setting	(0~55)	0	User Configured. See Table 15
2	Active Type	(0~1)	0	0: Closed to Activate 1: Open to Activate
3	Arming	(0~3)	2	0: From safety on 1: From Crank 2: Always 3: Never
4	Active Actions	(0~4)	1	0: Warning; 1: Shutdown; 2: Trip and stop 3: Trip 4: Indication
5	Active Delay	(0~20.0)s	2.0	Time from detecting active to confirm
6	Description			LCD display detailed contents when the input is active.
Digital Input Port 6				
1	Contents Setting	(0~55)	0	User defined .See Table 15
2	Active Type	(0~1)	0	0: Closed to Activate 1: Open to Activate
3	Arming	(0~3)	2	0: From safety on 1: From Crank 2: Always 3: Never
4	Active Actions	(0~4)	2	0: Warning; 1: Shutdown; 2: Trip and stop



No.	Items	Parameters	Defaults	Description
				3: Trip 4: Indication
5	Active Delay	(0~20.0)s	2.0	Time from detecting active to confirm
6	Description			LCD display detailed contents when the input is active.
Digital Input Port 7				
1	Contents Setting	(0~55)	5	Lamp Test. See Table 15
2	Active Type	(0~1)	0	0: Closed to Activate 1: Open to Activate
Digital Input Port 8				
1	Contents Setting	(0~55)	0	User Configured .See Table 15
2	Active Type	(0~1)	0	0: Closed to Activate 1: Open to Activate
3	Arming	(0~3)	2	0: From safety on 1: From Crank 2: Always 3: Never
4	Active Actions	(0~4)	0	0: Warning; 1: Shutdown; 2: Trip and stop 3: Trip 4: Indication
5	Active Delay	(0~20.0)s	2.0	Time from detecting active to confirm
6	Description			LCD display detailed contents when the input is active.
Relay Outputs				
Relay Output Port 1				
1	Contents Setting	(0~299)	1	Custom Period 1. See Table 14
2	Active Type	(0~1)	0	0: Output(N/O) 1: Output(N/C)
Relay Output Port 2				
1	Contents Setting	(0~299)	35	Idle Control See Table 14
2	Active Type	(0~1)	0	0: Output(N/O) 1: Output(N/C)
Relay Output Port 3				
1	Contents Setting	(0~299)	29	Close Generator. See Table 14
2	Active Type	(0~1)	0	0: Output(N/O) 1: Output(N/C)
Relay Output Port 4				
1	Contents Setting	(0~299)	31	Reserved. See Table 14
2	Active Type	(0~1)	0	0: Output(N/O) 1: Output(N/C)
Relay Output Port 5				
1	Contents Setting	(0~299)	38	Energise to Stop. See Table 14
2	Active Type	(0~1)	0	0: Output(N/O) 1: Output(N/C)
Relay Output Port 6				
1	Contents Setting	(0~299)	48	Common Alarm. See Table 14

No.	Items	Parameters	Defaults	Description
2	Active Type	(0~1)	0	0: Output(N/O) 1: Output(N/C)

8.2 ENABLE DEFINITION OF PROGRAMMABLE OUTPUT PORTS

8.2.1. ENABLE DEFINITION OF PROGRAMMABLE OUTPUT PORTS FORM

Table 14 – Definition Content of Programmable Output Ports

No.	Type	Description
0	Not Used	
1	Custom Period 1	Details of function description please see the following.
2	Custom Period 2	
3	Custom Period 3	
4	Custom Period 4	
5	Custom Period 5	
6	Custom Period 6	
7	Custom Combined 1	
8	Custom Combined 2	
9	Custom Combined 3	
10	Custom Combined 4	
11	Custom Combined 5	
12	Custom Combined 6	
13	Oil Pre-heat Output	
14	Reserved	
15	Reserved	
16	Reserved	
17	Air Flap Control	Action when over speed shutdown and emergence stop. It also can close the air in flow.
18	Audible Alarm	Action when warning, shutdown, trips. Can be connected with annunciator externally. When “alarm mute” configurable input port is active, it can remove the alarm.
19	Louver Control	Action in genset starting and disconnect when genset stopped completely.
20	Fuel Pump Control	It is controlled by fuel pump of level sensor’s limited threshold.
21	Heater Control	It is controlled by heating of temperature sensor’s setting bound.
22	Cooler Control	It is controlled by cooler of temperature sensor’s setting bound.
23	Fuel Pre-supply	Action when start and running safety period.
24	Generator Excite	Output in start period. If there is no generator frequency during hi-speed running, output for 2 seconds again.
25	Pre-lubricate	Actions in period of pre-heating to safety run.
26	Remote Control	This port is controlled by communication (PC).



No.	Type	Description
27	Reserved	
28	Reserved	
29	Close Generator	Control generator to take load.
30	Open Breaker	Control generator to off load.
31	Reserved	
32	Reserved	
33	Start Relay	
34	Fuel Relay	Action when genset is cranking and disconnect when stopped completely.
35	Idle Control	Used for engine which has idles. Close before starting and open when enter into warming up; Close during stopping idle process and open when stop is completed.
36	Speed Raise Relay	Action during in warming up process.
37	Speed Drop Relay	Action between the periods from “stop idle” to “failed to stop”.
38	Energise to Stop	Used for engines with ETS electromagnet. Close when stop idle is over and open when pre-set “ETS delay” is over.
39	Speed Drop Pulse	Active 0.1s when controller enters into stop idle, used for control part of ECU dropping to idle speed.
40	ECU Stop	Used for ECU engine and control its stop.
41	ECU Power Supply	Used for ECU engine and control its power.
42	Speed Raise Pulse	Active 0.1s when controller enters into warming up delay; used for control part of ECU raising to normal speed.
43	Crank Success	Close when detects a successful start signal.
44	Generator OK	Action when generator is normal.
45	Generator Available	Action in period of generator ok to hi-speed cooling.
46	Reserved	
47	Reserved	
48	Common Alarm	Action when genset common warning, common shutdown, common trips alarm.
49	Common Trip and Stop	Action when common trip and stop alarm occurs.
50	Common Shutdown	Action when common shutdown alarm occurs.
51	Common Trip	Action when common trips alarm occurs.
52	Common Warning	Action in common when warning alarm occurs.
53	Reserved	
54	Battery Over Voltage	Action when battery's over voltage warning alarm occurs.
55	Battery Under Voltage	Action when battery's low voltage warning alarm occurs.
56	Charge Alternator Failure	Action when charge failure warning alarm occurs.
57	Reserved	
58	Reserved	

No.	Type	Description
59	Reserved	
60	ECU Warning	Indicate ECU sends a warning signal.
61	ECU Shutdown	Indicate ECU sends a shutdown signal.
62	ECU Communication Failure	Indicate controller not communicates with ECU.
63	Reserved	
64	Reserved	
65	Reserved	
66	Reserved	
67	Reserved	
68	Reserved	
69	Digital Input 1 Active	Action when input port 1 is active
70	Digital Input 2 Active	Action when input port 2 is active
71	Digital Input 3 Active	Action when input port 3 is active
72	Digital Input 4 Active	Action when input port 4 is active
73	Digital Input 5 Active	Action when input port 5 is active
74	Digital Input 6 Active	Action when input port 6 is active
75	Digital Input 7 Active	Action when input port 7 is active
76	Digital Input 8 Active	Action when input port 8 is active
77-80	Reserved	
81-96	Expand Digital Input 1-16	Action when extend switch input port is active.
97-98	Reserved	
99	Emergency Stop	Action when emergency stop alarm occurs.
100	Fail to Start	Action when failed start alarm occurs.
101	Fail to Stop	Action when failed stop alarm occurs.
102	Under Speed Warning	Action when under speed alarm occurs.
103	Under Speed Shutdown	Action when under speed shuts down.
104	Over Speed Warning	Action when over speed warns.
105	Over Speed Shutdown	Action when over speed shutdown alarm occurs.
106	Reserved	
107	Reserved	
108	Reserved	
109	AC Over Freq Warn	Action when generator over frequency warning occurs.
110	AC Over Freq Shutdown	Action when generator over frequency shutdown alarm occurs.
111	AC Over Volt Warning	Action when generator over voltage warning occurs.
112	AC Over Volt Shutdown	Action when generator over voltage shutdown occurs.
113	AC Under Freq Warn	Action when generator low frequency warning occurs.
114	AC Under Freq. Shutdown	Action when generator low frequency shutdown occurs.
115	AC Under Volt. Warn	Action when generator low voltage warning occurs.
116	AC Under Volt. Shutdown	Action when generator low voltage shutdown occurs.
117	AC Loss of Phase	Action when generator loss phase.
118	AC Phase Rotation	Action when generator reverse phase.
119	Reserved	

No.	Type	Description
120	AC Over Power	Action when controller detects AC generator has over power.
121	Reserved	
122	AC Reverse Power	Action when controller detects AC generator has reverse power.
123	AC Over Current	Action when controller detects AC generator over current.
124	Reserved	
125	DC Over Volt Warn	Action when controller detects DC generator over voltage.
126	DC Over Volt Shutdown	Action when controller detects DC generator over voltage.
127	DC Over Current	Action when controller detects DC generator over current.
128	DC Over Power	Action when controller detects DC generator over power.
129~138	Reserved	
139	High Temperature Warn	Action when hi-temperature warning occurs.
140	Low Temperature Warn	Action when low temperature warning occurs.
141	High Temperature Shutdown	Action when hi-temperature shutdown alarm occurs.
142	Reserved	
143	Low Oil Pressure Warn	Action when low oil pressure warning occurs.
144	Low Oil Pressure Shutdown	Action when low oil pressure shutdown occurs.
145	Oil Pressure Open Circuit	Action when oil pressure sensor is open circuit.
146	Reserved	
147	Low Fuel Level	Action when controller has low oil level alarm.
148	Reserved	
149	Reserved	
150	Flexible Sensor 1 High Warn	
151	Flexible Sensor 1 Low Warn	
152	Flexible Sensor 1 High Shutdown	
153	Flexible Sensor 1 Low Shutdown	
154	Flexible Sensor 2 High Warn	
155	Flexible Sensor 2 Low Warn	
156	Flexible Sensor 2 High Shutdown	
157	Flexible Sensor 2 Low Shutdown	
158~161	Reserved	
162	Exp1 Ch15 High Shut	



No.	Type	Description
163	Exp1 Ch15 High Warn	
164	Exp1 Ch15 Low Shut	
165	Exp1 Ch15 Low Warn	
166	Exp1 Ch16 High Shut	
167	Exp1 Ch16 High Warn	
168	Exp1 Ch16 Low Shut	
169	Exp1 Ch16 Low Warn	
170	Exp1 Ch17 High Shut	
171	Exp1 Ch17 High Warn	
172	Exp1 Ch17 Low Shut	
173	Exp1 Ch17 Low Warn	
174	Exp1 Ch18 High Shut	
175	Exp1 Ch18 High Warn	
176	Exp1 Ch18 Low Shut	
177	Exp1 Ch18 Low Warn	
178	Exp1 Ch19 High Shut	
179	Exp1 Ch19 High Warn	
180	Exp1 Ch19 Low Shut	
181	Exp1 Ch19 Low Warn	
182	Exp1 Ch20 High Shut	
183	Exp1 Ch20 High Warn	
184	Exp1 Ch20 Low Shut	
185	Exp1 Ch20 Low Warn	
186	Exp1 Ch21 High Shut	
187	Exp1 Ch21 High Warn	
188	Exp1 Ch21 Low Shut	
189	Exp1 Ch21 Low Warn	
190	Exp1 Ch22 High Shut	
191	Exp1 Ch22 High Warn	
192	Exp1 Ch22 Low Shut	
193	Exp1 Ch22 Low Warn	
194	Exp1 Ch23 High Shut	
195	Exp1 Ch23 High Warn	
196	Exp1 Ch23 Low Shut	
197	Exp1 Ch23 Low Warn	
198	Exp1 Ch24 High Shut	
199	Exp1 Ch24 High Warn	
200	Exp1 Ch24 Low Shut	
201	Exp1 Ch24 Low Warn	
202-229	Reserved	
230	At Stop Mode	Action when system is in stop mode.
231	At Manual Mode	Action when system is in Manual mode.
232	Reserved	
233	At Auto Mode	Action when system is in Auto mode.
234	Generator Load	



No.	Type	Description
235	Reserved	
236~239	Reserved	
240~279	PLC Flag 1-40	Action when PLC flag is 1.
280~299	Reserved	

SmartGen

8.2.2. CUSTOM PERIOD OUTPUT

Defined Period output is composed by 2 parts, **period output S1** and **condition output S2**.



While **S1** and **S2** are **TRUE** synchronously, **OUTPUT**;

While **S1** or **S2** is **FALSE**, **NOT OUTPUT**.

Period output S1, can set generator's one or more period output freely, can set the delayed time and output time after enter into period.

Condition output S2; can set as any conditions in output ports.

▲NOTE: when delay time and output time both are 0 in period output **S1**, it is **TRUE** in this period.

Example,

Output period: start

Delay output time: 2s

Output time: 3s

Condition output contents: output port 1 is active

Close when condition output active/inactive: close when active (disconnect when inactive);

Output port 1 active, after enter "starts time" and delay 2s, this defined period output is outputting, after 3s, stop outputting;

Output port 1 inactive, defined output period is not outputting.

8.2.3. CUSTOM COMBINED OUTPUT

Defined combination output is composed by 3 parts, condition output **S1** or **S2** and condition output **S3**.

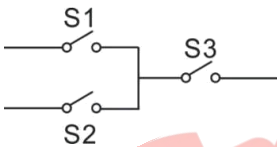

S1 or **S2** is **TRUE**, while **S3** is **TRUE**, Defined combination output is outputting;

S1 and **S2** are **FALSE**, or **S3** is **FALSE**, Defined combination output is not outputting.

▲NOTE: **S1, S2, S3** can be set as any contents except for "defined combination output" in the output setting.

▲NOTE: 3 parts of defined combination output (**S1, S2, S3**) couldn't include or recursively include themselves.

Example,

Contents of probably condition output **S1**: output port 1 is active;

Close when probably condition output **S1** is active /inactive: close when active (disconnect when inactive);

Contents of probably condition output **S2**, output port 2 is active;

Close when probably condition output **S2** is active /inactive: close when active (disconnect when inactive);

Contents of probably condition output **S3**: output port 3 is active;

Close when probably condition output **S3** is active /inactive: close when active (disconnect when inactive);

When input port 1 active or input port 2 active, if input port 3 is active, Defined combination output is outputting; If input port 3 inactive, Defined combination output is not outputting;

When input port 1 inactive and input port 2 inactive, whatever input port 3 is active or not, Defined combination output is not outputting.

8.3 DEFINED CONTENTS OF CONFIGURABLE INPUT PORTS

All active when connect to grand (B-)

Table 15 - Enable Programmable Inputs

No.	Type	Description
0	Users Configured	Including following functions, Indication: indicate only, not warning or shutdown. Warning: warn only, not shutdown. Shutdown: alarm and shutdown immediately Trip and stop: alarm, generator unloads and shutdown after hi-speed cooling Trip: alarm, generator unloads but not shutdown. Never: input inactive. Always: input is active all the time. From crank: detecting as soon as start. From safety on: detecting after safety on run delay.
1	Reserved	
2	Alarm Mute	Can prohibit "Audible Alarm" output when input is active.
3	Reset Alarm	Can reset shutdown alarm and trip alarm when input is active.
4	60Hz Active	Use for CANBUS engine and it is 60Hz when input is active.
5	Lamp Test	All LED indicators are illuminating when input is active.
6	Panel Lock	All buttons in panel is inactive except direction and exit buttons and there is  in the right of first row in LCD when input is active.
7	War Mode	All shutdown alarms except alarms of emergency stop and over speed shutdown are cannot stop the engine in the war mode.
8	Idle Mode	Under voltage/frequency/speed protection is inactive.
9	Auto Stop Inhibit	In Auto mode, during generator normal running, when input is active, inhibit generator shutdown automatically.
10	Auto Start Inhibit	In Auto mode, inhibit generator start automatically when input is active.
11	Scheduled Run Inhibit	In Auto mode, inhibit scheduled run genset when input is active.
12	Reserved	
13	Generator Close Status	Connect generator loading switch's Aux. Point.
14	Generator Load Inhibit	Prohibit genset switch on when input is active.
15	Reserved	
16	Reserved	
17	Auto Mode Lock	When input is active, controller enters into auto mode; mode selection buttons are inactive.
18	Auto Mode Inhibit	When input is active, controller won't work under auto mode. Auto mode key and simulate auto key input does not work.
19	Reserved	
20	Reserved	

No.	Type	Description
21	Alarm Stop Inhibit	All shutdown alarms are prohibited except emergence stop.(Means battle mode or override mode)
22	Instrument Mode	All outputs are prohibited in this mode.
23	Reserved	
24	Reset Maintenance Alarm	Controller will set maintenance time and date as default when input is active.
25	Reserved	
26	High Temperature Shutdown	Connected sensor digital input.
27	Low Oil Pressure Shutdown	Connected sensor digital input.
28	Remote Start On Load	In Auto mode, when input active, genset can be started automatically and take load after genset normal running; when input inactive, genset will stop automatically.
29	Remote Start Off Load	In Auto mode, when input is active, genset can be started automatically and NOT take load after genset normal running; when input is inactive, genset will stop automatically.
30	Manual Start Input	In Manual mode, when input active, genset will start automatically; when input inactive, genset will stop automatically
31	Reserved	
32	Reserved	
33	Simulate Stop Key	An external button can be connected and pressed as simulate panel.
34	Simulate Manual Key	
35	Reserved	
36	Simulate Auto Key	An external button can be connected and pressed as simulate panel.
37	Simulate Start Key	
38	Simulate Generator Close Key	
39	Simulate Generator Open Key	
40	Reserved	
41	Reserved	
42	Reserved	
43	Reserved	
44	Reserved	
45	Reserved	
46	Reserved	
47	Alt. Config. 1 Active	When input port is active, users can set different parameters to make it easy to select current configuration via input port.
48	Alt. Config. 2 Active	
49	Alt. Config. 3 Active	
50-55	Reserved	

8.4 SELECTION OF SENSORS

Table 16 - Sensors Selection

No.		Description	Remark
1	Temperature Sensor	0 Not Used 1 User Configured (Resistance) 2 User Config((4-20)mA) 3 User Config.(Voltage) 4 VDO 5 CURTIS 6 VOLVO-EC 7 DATCON 8 SGX 9 SGD 10 SGH 11 PT100 12 SUSUKI 13 PRO 14~15 Reserved	Defined resistance's range is (0~6)KΩ, default is SGD sensor.
2	Pressure Sensor	0 Not Used 1 User Configured (Resistance) 2 User Config((4-20)mA) 3 User Config.(Voltage) 4 VDO 10Bar 5 CURTIS 6 VOLVO-EC 7 DATCON 10Bar 8 SGX 9 SGD 10 SGH 11 VDO 5Bar 12 DATCON 5Bar 13 DATCON 7Bar 14 SUSUKI 15 PRO	Defined resistance's range is (0~6)KΩ, default is SGD sensor.
3	Oil Level Sensor	0 Not used 1 User Configured (Resistance) 2 User Config((4-20)mA) 3 User Config.(Voltage) 4 SGD 5 SGH 6-15 Reserved	Defined resistance's range is (0~6)KΩ, default is SGH sensor.

NOTE: Above curve types are suit for two flexible sensors, and the No.2 and No.3 items of fixed temperature/oil pressure/ level sensor configured as reserved.

8.5 CONDITIONS OF CRANK DISCONNECT SELECTION

Table 17 - Crank Disconnect Conditions Selection

No.	Setting description
0	Gen frequency
1	Speed
2	Speed + Gen frequency
3	Oil pressure
4	Oil pressure + Gen frequency
5	Oil pressure + Speed
6	Oil pressure + Speed + Gen frequency

▲NOTE:

- There are 3 conditions to make starter disconnected with engine, that is, speed, generator frequency and engine oil pressure. They all can be used separately. We recommend that engine oil pressure should be using with speed and generator frequency together, in order to make the starter motor is separated with engine immediately and can check crank disconnect exactly.
- Speed sensor is the magnetic equipment which be installed in starter for detecting flywheel teeth.
- When set as speed, must ensure that the number of flywheel teeth is as same as setting, otherwise, "over speed shutdown" or "under speed shutdown" may be caused.
- If genset without speed sensor please don't select corresponding items, otherwise, "start fail" or "loss speed signal" maybe caused.
- If genset without oil pressure sensor, please don't select corresponding items.
- If not select speed in crank disconnect setting, speed displayed on the LCD is converted by power generator frequency and generator poles.
- If gen mode select as 0 (DC), please confirm crank disconnect conditions conclude speed or oil pressure, otherwise, fail to start alarm may occurs.
- If gen mode select as 0 (DC), controller will not collect and display gen AC related electric data; if gen mode select as 1 (AC), controller will not collect and display gen DC related electric data

9 PARAMETERS SETTING

⚠CAUTION: Please change the controller parameters when generator is in standby mode only (e. g. Crank disconnect conditions selection, configurable input, configurable output, various delay), otherwise, shutdown and other abnormal conditions may happen.

⚠NOTE:

- 1) Maximum set value must over minimum set value in case that the condition of too high as well as too low will happen.
- 2) When setting the warning alarm, please set the correct return value; otherwise, maybe there is abnormal alarm. When setting the maximum value, the return value must less than set value; when setting the minimum value, the return value must over set value.
- 3) Please set the generator frequency value as low as possible when cranking, in order to make the starter be separated quickly as soon as crank disconnect.
- 4) Configurable input could not be set as same items; otherwise, there are abnormal functions. However, the configurable output can be set as same items.

SmartGen

10 SENSORS SETTING

- When reselect sensors, the sensor curve will be transferred into the standard value. For example, if temperature sensor is SGX (120°C resistor type), its sensor curve is SGX (120°C resistor type); if select the SGD (120°C resistor type), the temperature sensor curve is SGD curve.
- When there is difference between standard sensor curves and using sensor, user can adjust it in “curve type”.
- When input the sensor curve, X value (resistor) must be input from small to large, otherwise, mistake occurs.
- If select sensor type as “None”, sensor curve is not working.
- If corresponding sensor has alarm switch only, user must set this sensor as “None”, otherwise, maybe there is shutdown or warning.
- The headmost or backmost values in the vertical coordinates can be set as same as below,

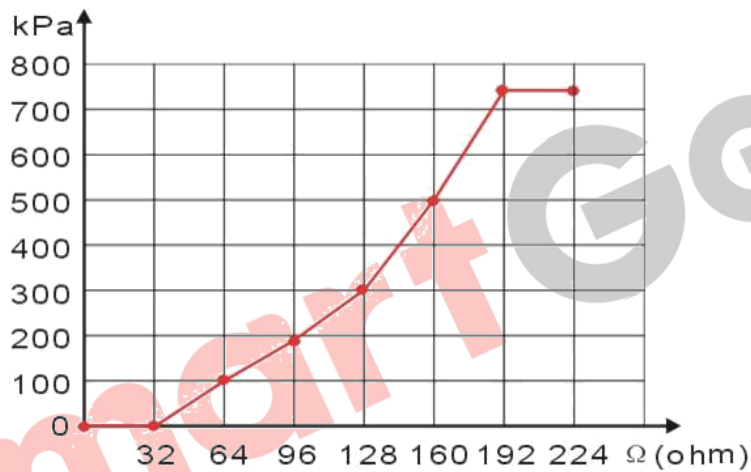

Fig. 2 - Sensor Curve Setting

Table 18 - Normal Pressure Unit Conversion Form

	N/m ² pa	kgf/cm ²	bar	psi
1Pa	1	1.02x10 ⁻⁵	1x10 ⁻⁵	1.45x10 ⁻⁴
1kgf/cm ²	9.8x10 ⁴	1	0.98	14.2
1bar	1x10 ⁵	1.02	1	14.5
1psi	6.89x10 ³	7.03x10 ⁻²	6.89x10 ⁻²	1

11 COMMISSIONING

Please make the under procedures checking before commissioning,

- Ensure all the connections are correct and wires diameter is suitable.
- Ensure that the controller DC power has fuse, controller's positive and negative connected to start battery are correct.
- Emergence stop must be connected with positive of start battery via scram button's normal close point and fuse.
- Take proper action to prevent engine to crank disconnect (e. g. Remove the connection wire of fuel valve). If checking is OK, make the start battery power on; choose manual mode and controller will executive routine.
- Set controller under manual mode, press "start" button, genset will start. After the setting times as setting, controller will send signal of Start Fail; then press "stop" to reset controller.
- Recover the action of stop engine start (e. g. Connect wire of fuel valve), press start button again, genset will start. If everything goes well, genset will normal run after idle running (if idle run be set). During this time, please watch for engine's running situations and AC generator's voltage and frequency. If abnormal, stop genset running and check all wires connection according to this manual.
- If there is any other question, please contact SmartGen's service.

SmartGen

12 TYPICAL APPLICATION

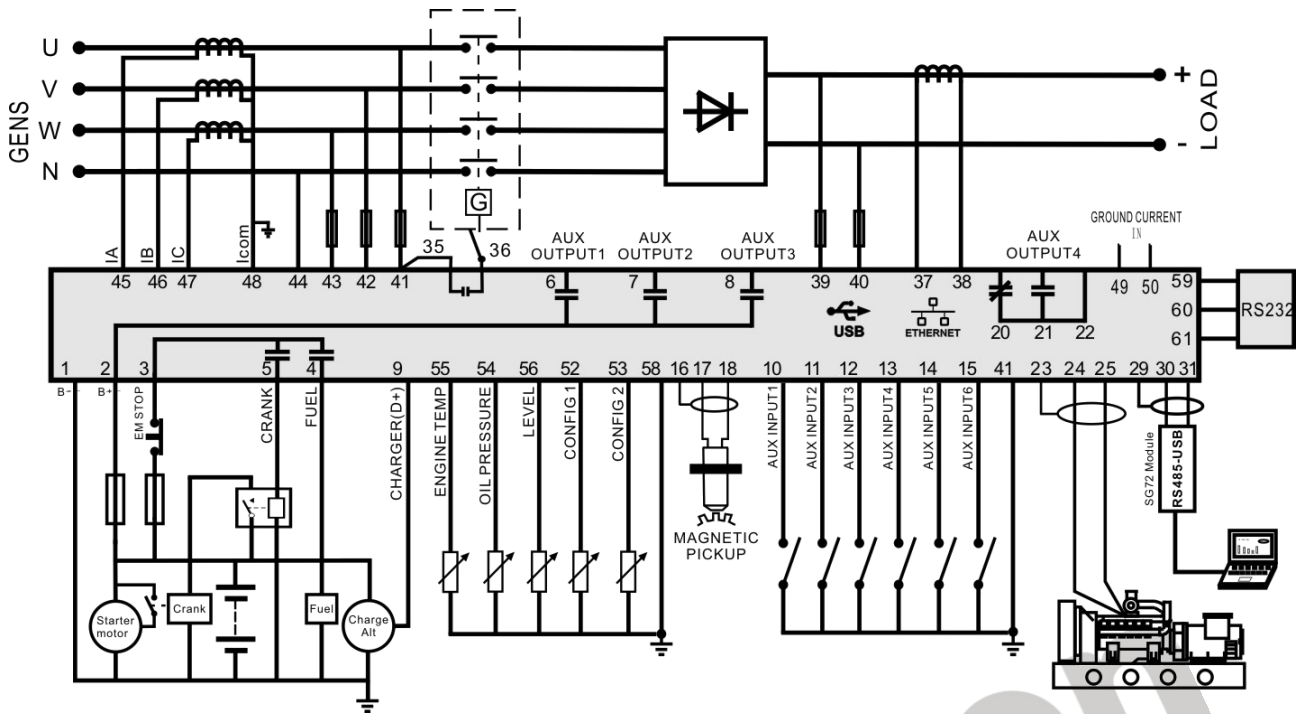

Fig.3 - HGM8110DC Typical Application Diagram

▲NOTE: B+ fuse: minimum 2A, and maximum 20A. Emergency fuse: maximum 32A. customers should select appropriate fuse based on the local situation.

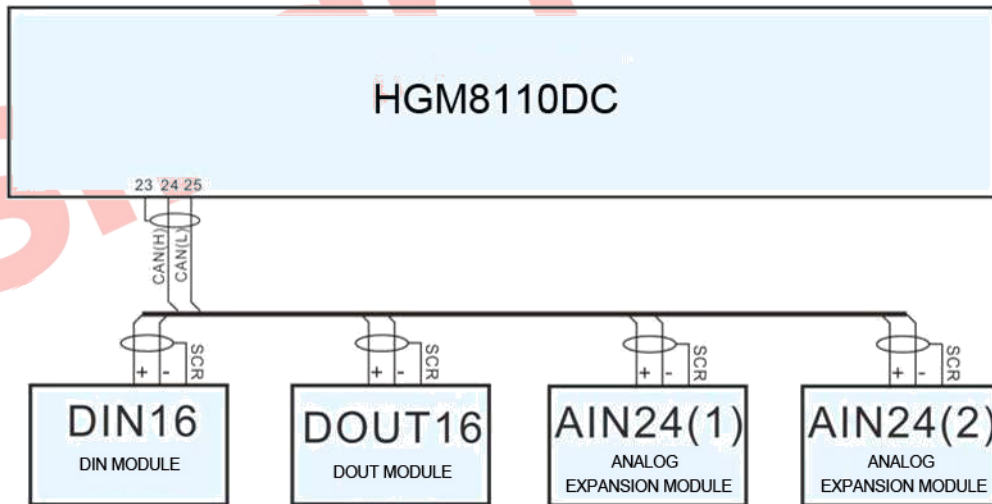

Fig.4 - HGM8110DC Expend Module Typical Application Diagram

13 INSTALLATION

13.1 OVERALL DIMENSION

Controller is panel built-in design; it is fixed by clips when installed. The controller's overall and cutout dimensions for panel, please refers to as following,

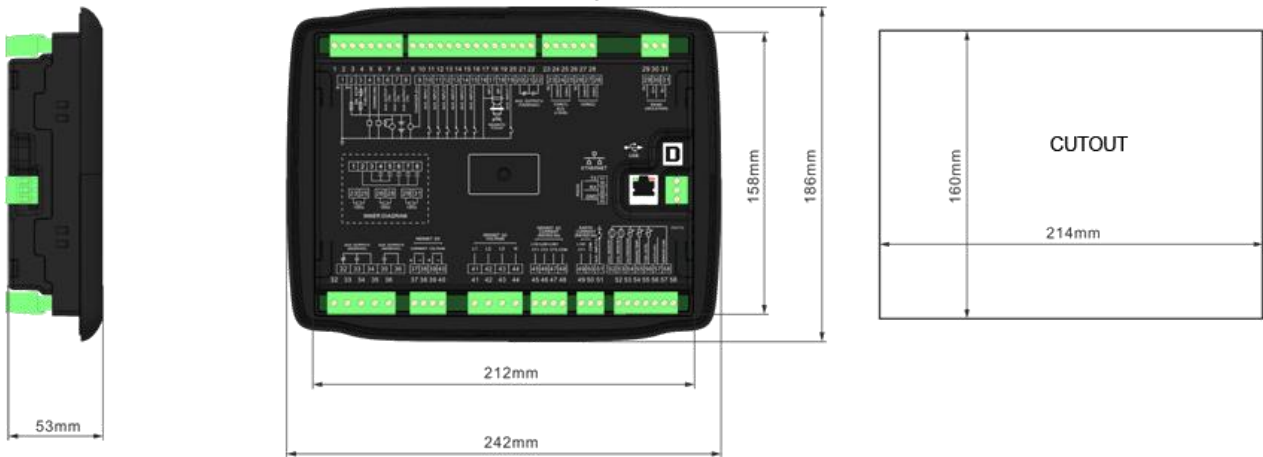

Fig.5 - Overall Dimensions

13.2 BATTERY VOLTAGE INPUT

HGM8110DC controller can suit for widely range of battery voltage DC(8~35)V. Negative of battery must be connected with the engine shell. Diameter of wire that connects from power supply to battery must be over 2.5mm². If floating charge configured, please firstly connect output wires of charger to battery's positive and negative directly, then, connect wires from battery's positive and negative to controller's positive and negative input ports in order to prevent charge disturbing the controller's normal working.

13.3 SPEED SENSOR INPUT

Speed sensor is the magnetic equipment which be installed in starter and for detecting flywheel teeth. Its connection wires to controller should apply for 2 cores shielding line. The shielding layer should connect to No. 16 terminal in controller while another side is hanging in air. The else two signal wires are connected to No.17 and No.18 terminals in controller. The output voltage of speed sensor should be within AC(1~24)V (effective value) during the full speed. AC12V is recommended (in rated speed). When install the speed sensor, let the sensor is spun to contacting flywheel first, then, port out 1/3 lap, and lock the nuts of sensor at last.

13.4 OUTPUT AND EXPAND RELAYS

⚠CAUTION: All outputs of controller are relay contact output type. If need to expand the relays, please add freewheel diode to both ends of expand relay's coils (when coils of relay has DC current) or, increase resistance-capacitance return circuit (when coils of relay has AC current), in order to prevent disturbance to controller or others equipment.

13.5 AC INPUT

Current input of controller must be connected to outside current transformer. And the current transformer's secondary side current must be 5A. At the same time, the phases of current transformer and input voltage must correct. Otherwise, the current of collecting and active power maybe not correct.

▲NOTE: ICOM port must be connected to negative pole of battery.



WARNING! When there is load current, transformer's secondary side prohibit open circuit.

13.6 WITHSTAND VOLTAGE TEST

▲CAUTION! When controller had been installed in control panel, if need the high voltage test, please disconnect controller's all terminal connections, in order to prevent high voltage into controller and damage it.

SmartGen

14 CONNECTIONS OF CONTROLLER WITH J1939 ENGINE

14.1 CUMMINS ISB/ISBE

Table 19 - Connector B

Terminals of controller	Connector B	Remark
Fuel relay output	39	
Start relay output	-	Connect with starter coil directly.
Auxiliary output 1	Expand 30A relay, battery voltage of 01,07,12,13 is supplied by relay.	ECU power Set auxiliary output 1 as "ECU power".

Table 20 – 9 Pins Connector

Terminals of controller	9 pins connector	Remark
CAN GND	SAE J1939 shield	CAN communication shielding line (connect with ECU terminal only).
CAN(H)	SAE J1939 signal	Impedance 120Ω connecting line is recommended.
CAN(L)	SAE J1939 return	Impedance 120Ω connecting line is recommended.

Engine type: Cummins ISB

14.2 CUMMINS QSL9

Suitable for CM850 engine control mode

Table 21 – 50 Pins Connector

Terminals of controller	50 pins connector	Remark
Fuel relay output	39	
Start relay output	-	Connect to starter coil directly.

Table 22 – 9 Pins Connector

Terminals of controller	9 pins connector	Remark
CAN GND	SAE J1939 shield-E	CAN communication shielding line (connect with ECU terminal only).
CAN(H)	SAE J1939 signal-C	Using impedance 120Ω connecting line.
CAN(L)	SAE J1939 return-D	Using impedance 120Ω connecting line.

Engine type: Cummins-CM850

14.3 CUMMINS QSM11(import)

It is suitable for CM570 engine control module. Engine type is QSM11 G1, QSM11 G2.

Table 23 - C1 Pin Connector

Terminals of controller	C1 connector	Remark
Fuel relay output	5&8	Outside expand relay, when fuel output, making port 5 and port 8 of C1 be connected.
Start relay output	-	Connect to starter coil directly.

Table 24 – 3 Pins Data Link Connector

Terminals of controller	3 pins data link connector	Remark
CAN GND	C	CAN communication shielding line (connect with ECU terminal only).
CAN(H)	A	Using impedance 120Ω connecting line.
CAN(L)	B	Using impedance 120Ω connecting line.

Engine type: Cummins ISB

14.4 CUMMINS QSX15-CM570

It is suitable for CM570 engine control module. Engine type is QSX15.

Table 25 – 50 Pins Connector

Terminals of controller	50 pins connector	Remark
Fuel relay output	38	Oil spout switch
Start relay output	-	Connect to starter coil directly.

Table 26 – 9 Pins Connector

Terminals of controller	9 pins connector	Remark
CAN GND	SAE J1939 shield-E	CAN communication shielding line (connect with ECU terminal only).
CAN(H)	SAE J1939 signal-C	Using impedance 120Ω connecting line.
CAN(L)	SAE J1939 return-D	Using impedance 120Ω connecting line.

Engine type: Cummins QSX15-CM570

14.5 CUMMINS GCS-MODBUS

It is suitable for GCS engine control module. RS485-MODBUS used to read information of engine. Engine types are QSX15, QST30, QSK23 / 45/60/78 and so on.

Table 27 - D-SUB Connector 06

Terminals of controller	D-SUB connector 06	Remark
Fuel relay output	5&8	Outside expand relay, when fuel output, making port 05 and 08 of the connector 06 be connected.
Start relay output	-	Connect to starter coil directly.

Table 28 - D-SUB Connector 06

Terminals of controller	D-SUB connector 06	Remark
RS485 GND	20	CAN communication shielding line (connect with ECU terminal only).
RS485+	21	Using impedance 120Ω connecting line.
RS485-	18	Using impedance 120Ω connecting line.

Engine type: Cummins QSK-MODBUS, Cummins QST-MODBUS, Cummins QSX-MODBUS

14.6 CUMMINS QSM11

Table 29 - Engine OEM Connector

Terminals of controller	OEM connector of engine	Remark
Fuel relay output	38	
Start relay output	-	Connect with starter coil directly
CAN GND	-	CAN communication shielding line (connect with controller's this terminal only).
CAN(H)	46	Using impedance 120Ω connecting line.
CAN(L)	37	Using impedance 120Ω connecting line.

Engine type: common J1939

14.7 CUMMINS QSZ13

Table 30 - Engine OEM Connector

Terminals of controller	OEM connector of engine	Remark
Fuel relay output	45	
Start relay output	-	Connect to starter coil directly
Auxiliary output 1	16&41	Setting to idle speed control, normally open output. Making 16 connect to 41 during high-speed running of controller via external expansion relay.
Auxiliary output 2	19&41	Setting to pulse raise speed control, normally open output. Making 19 connect with 41 for 0.1s during high-speed warming of controller via external expansion relay.
CAN GND	-	CAN communication shielding line (connect with controller's this terminal only).
CAN(H)	1	Using impedance 120Ω connecting line.
CAN(L)	21	Using impedance 120Ω connecting line.

Engine type: Common J1939

14.8 DETROIT DIESEL DDEC III / IV

Table 31 - Engine CAN Connector

Terminals of controller	CAN port of engine	Remark
Fuel relay output	Expand 30A relay, battery voltage of ECU is supplied by relay.	
Start relay output	-	Connect to starter coil directly.
CAN GND	-	CAN communication shielding line (connect with controller's terminal only).
CAN(H)	CAN(H)	Using impedance 120Ω connecting line.
CAN(L)	CAN(L)	Using impedance 120Ω connecting line.

Engine type: Common J1939

14.9 DEUTZ EMR2

Table 32 - F Connector

Terminals of controller	F connector	Remark
Fuel relay output	Expand 30A relay, battery voltage of 14 is supplied by relay. Fuse is 16A.	
Start relay output	-	Connect to starter coil directly.
-	1	Connect to battery negative pole.
CAN GND	-	CAN communication shielding line (connect with controller's terminal only).
CAN(H)	12	Impedance 120Ω connecting line is recommended.
CAN(L)	13	Impedance 120Ω connecting line is recommended.

Engine type: VolvoEDC4

14.10 JOHN DEERE

Table 34 – 21 Pins Connector

Terminals of controller	21 pins connector	Remark
Fuel relay output	G,J	
Start relay output	D	
CAN GND	-	CAN communication shielding line (connect with controller's terminal only).
CAN(H)	V	Using impedance 120Ω connecting line.
CAN(L)	U	Using impedance 120Ω connecting line.

Engine type: John Deere

14.11 MTU MDEC

Suitable for MTU engines, 2000 series, 4000series

Table 34 - X1 Pin Connector

Terminals of controller	X1 connector	Remark
Fuel relay output	BE1	
Start relay output	BE9	
CAN GND	E	CAN communication shielding line (connect with one terminal only).
CAN(H)	G	Using impedance 120Ω connecting line.
CAN(L)	F	Using impedance 120Ω connecting line.

Engine type: MTU-MDEC-303

14.12 MTU ADEC(SMART MODULE)

It is suitable for MTU engine with ADEC (ECU8) and SMART module.

Table 35 - ADEC(X1 Connector)

Terminals of controller	ADEC (X1port)	Remark
Fuel relay output	X1 10	X1 Terminal 9 Connected to negative of battery
Start relay output	X1 34	X1 Terminal 33 Connected to negative of battery

Table 36 - ADEC(X4 Connector)

Terminals of controller	SMART (X4 port)	Remark
CAN GND	X4 3	CAN communication shielding line (connect to controller's this terminal only).
CAN(H)	X4 1	Using impedance 120Ω connecting line.
CAN(L)	X4 2	Using impedance 120Ω connecting line.

Engine type: mtu-ADEC

14.13 MTU ADEC (SAM MODULE)

It is suitable for MTU engine with ADEC (ECU7) and SAM module.

Table 37 - ADEC(X1 Connector)

Terminals of controller	ADEC (X1port)	Remark
Fuel relay output	X1 43	X1 Terminal 28 Connected to negative of battery.
Start relay output	X1 37	X1 Terminal 22 Connected to negative of battery.

Table 38 - SAM(X23 Connector)

Terminals of controller	SAM (X23 port)	Remark
CAN GND	X23 3	CAN communication shielding line (connect with controller's this terminal only).
CAN(H)	X23 2	Using impedance 120Ω connecting line.
CAN(L)	X23 1	Using impedance 120Ω connecting line.

Engine type: Common J1939

14.14 PERKINS

It is suitable for ADEM3/ ADEM4 engine control module. Engine type is 2306, 2506, 1106, and 2806.

Table 39 - Connector

Terminals of controller	Connector	Remark
Fuel relay output	1,10,15,33,34	
Start relay output	-	Connect to starter coil directly.
CAN GND	-	CAN communication shielding line (connect with controller's terminal only).
CAN(H)	31	Using impedance 120Ω connecting line.
CAN(L)	32	Using impedance 120Ω connecting line.

Engine type: Perkins

14.15 SCANIA

It is suitable for S6 engine control module. Engine type is DC9, DC12, and DC16.

Table 40 - B1 Connector

Terminals of controller	B1 connector	Remark
Fuel relay output	3	
Start relay output	-	Connect to starter coil directly.
CAN GND	-	CAN communication shielding line (connect with controller's terminal only).
CAN(H)	9	Using impedance 120Ω connecting line.
CAN(L)	10	Using impedance 120Ω connecting line.

Engine type: Scania

14.16 VOLVO EDC3

Suitable engine control mode is TAD1240, TAD1241, and TAD1242.

Table 41 - "Stand alone" Connector

Terminals of controller	"Stand alone" connector	Remark
Fuel relay output	H	
Start relay output	E	
Auxiliary output 1	P	ECU power Configurable output 1, "ECU power" .

Table 42 - "Data bus" Connector

Terminals of controller	"Data bus" connector	Remark
CAN GND	-	CAN communication shielding line (connect with controller's terminal only).
CAN(H)	1	Using impedance 120Ω connecting line.
CAN(L)	2	Using impedance 120Ω connecting line.

Engine type: Volvo

▲NOTE: When this engine type is selected, preheating time should be set to at least 3 seconds.

14.17 VOLVO EDC4

Suitable engine types: TD520, TAD520 (optional), TD720, TAD720 (optional), TAD721, TAD722, and TAD732.

Table 43 - Connector

Terminals of controller	Connector	Remark
Fuel relay output	Expanded 30A relay, and relay offers battery voltage for terminal14. Fuse is 16A	
Start relay output	-	Connect to starter coil directly.
	1	Connected to negative of battery.
CAN GND	-	CAN communication shielding line (connect with controller's terminal only).
CAN(H)	12	Using impedance 120Ω connecting line.
CAN(L)	13	Using impedance 120Ω connecting line.

Engine type: VolvoEDC4

14.18 VOLVO-EMS2

Volvo Engine types are TAD734, TAD940, TAD941, TAD1640, TAD1641, and TAD1642.

Table 44 - Engine CAN Connector

Terminals of controller	Engine's CAN port	Remark
Auxiliary output 1	6	ECU stop Configurable output 1 "ECU stop".
Auxiliary output 2	5	ECU power Configurable output 2 "ECU power".
	3	Negative power
	4	Positive power
CAN GND	-	CAN communication shielding line (connect with controller's terminal only).
CAN(H)	1(Hi)	Using impedance 120Ω connecting line.
CAN(L)	2(Lo)	Using impedance 120Ω connecting line.

Engine type: Volvo-EMS2

▲NOTE: When this engine type is selected, preheating time should be set to at least 3 seconds.

14.19 YUCHAI

It is suitable for BOSCH common rail pump engine.

Table 45 - Engine 42 Pins Connector

Terminals of controller	Engine 42 pins port	Remark
Fuel relay output	1.40	Connect to engine ignition lock.
Start relay output	-	Connect to starter coil directly.
CAN GND	-	CAN communication shielding line (connect with controller's this terminal only).
CAN(H)	1.35	Using impedance 120Ω connecting line.
CAN(L)	1.34	Using impedance 120Ω connecting line.

Table 46 - Engine 2 Pins Connector

Battery	Engine 2 pins	Remark
Battery negative	1	Wire diameter 2.5mm ²
Battery positive	2	Wire diameter 2.5mm ²

Engine type: BOSCH

14.20 WEICHAI

It is suitable for Weichai BOSCH common rail pump engine.

Table 47 - Engine Connector

Terminals of controller	Engine port	Remark
Fuel relay output	1.40	Connect to engine ignition lock.
Start relay output	1.61	
CAN GND	-	CAN communication shielding line (connect to the controller at this end only).
CAN(H)	1.35	Using impedance 120Ω connecting line.
CAN(L)	1.34	Using impedance 120Ω connecting line.

Engine type: GTSC1

▲NOTE: If there is any question of connection between controller and ECU communication, please feel free to contact SmartGen’s service.

15 ETHERNET INTERFACE

15.1 ETHERNET INTERFACE INTRODUCTION

ETHERNET port, used for controller monitoring, can realize network client connection.

▲NOTE: After changing controller network parameters (e.g. IP address, sub network mask etc.) new settings will take effect only after the controller is restarted.

15.2 NETWORK CLIENT CONNECTION

When the controller is used as network client, it can be monitored via network port using TCP ModBus protocol.

The procedure is as follows:

- Set IP address and sub network of the controller. The IP address must in the same network segment as the IP address of monitoring equipment (e.g. PC) e.g.: if monitoring equipment IP address is 192.168.0.16, controller IP can be 192.168.0.18, sub network mask 255.255.255.0
- Connect the controller. It can be connected to the monitoring equipment directly using network cable or via switchboard.
- The communication between the controller and monitoring equipment is carried out using TCP ModBus protocol.

▲NOTE: In this connection mode controller parameters can be set. SmartGen provides testing software for this connection mode. Communication protocol can be obtained from the SmartGen service.

15.3 CONTROLLER AND NETWORK CABLE CONNECTION

Table 48 - Controller Internet Access

No.	Name	Description
1	TX+	Tranceive Data+
2	TX-	Tranceive Data-
3	RX+	Receive Data+
4	NC	Not connected
5	NC	Not connected
6	RX-	Receive Data-
7	NC	Not connected
8	NC	Not connected

- Controller connect with PC with a line of cable

For this connection crossover cable must be used.

Crossover cable: EIA/TIA 568A standard on one end and EIA/TIA 568B on the other end.

▲NOTE: If PC network port has Auto MDI/MDIX function, parallel cable can also be used.

- Controller and PC connection via switchboard (or router).

Parallel lines must be used.

Parallel cable: EIA/TIA 568A standard on both ends or EIA/TIA 568B standard on both ends.

▲NOTE: If switchboard (or router) network port has Auto MDI/MDIX function, crossover cable can also be used.

16 FAULT FINDING

Table 49 - Troubleshooting

Symptoms	Possible Solutions
Controller no response with power.	Check starting batteries; Check controller connection wirings; Check DC fuse.
Genset shutdown	Check the water/cylinder temperature is too high or not; Check the genset AC voltage; Check DC fuse.
Controller emergency stop	Check emergence stop button is correct or not; Check whether the starting battery positive be connected with the emergency stop input; Check whether the circuit is open.
Low oil pressure alarm after crank disconnect	Check the oil pressure sensor and its connections.
High water temp. alarm after crank disconnect	Check the temperature sensor and its connections.
Shutdown Alarm in running	Check related switch and its connections according to the information on LCD; Check programmable inputs.
Crank not disconnect	Check fuel oil circuit and its connections; Check starting batteries; Check speed sensor and its connections; Refer to engine manual.
Starter no response	Check starter connections; Check starting batteries.
Genset running while ATS not transfer	Check ATS; Check the connections between ATS and controllers.
RS485 communication is abnormal	Check connections; Check setting of COM port is correct or not; Check RS485's connections of A and B is reverse connect or not; Check RS485 transfer model whether damage or not; Check communication port of PC whether damage.
ECU communication failed	Check connections of CAN high and low polarity; Check if correctly connected of 120Ω resistor; Check if type of engine correct; Check if connections from controller to engine and setting of outputs correct.
ECU warning or stop	Get information from LCD of alarm page; If there is detailed alarm, check engine according to description. If not, please refer to engine manual according to SPN alarm code.